



Chaska

2023 Update

Standard Detail Plates

Chaska Municipal Services Building

660 Victoria Drive, Chaska, MN 55318
952-448-4335



GENERAL

- GEN-1A STANDARD DETAILS INDEX
- GEN-1B STANDARD DETAILS INDEX
- GEN-1C STANDARD DETAILS INDEX
- GEN-1D STANDARD DETAILS INDEX
- GEN-2 DRAFTING GUIDELINES
- GEN-3 STANDARD PROJECT COVER SHEET
- GEN-4 PERMANENT BARRICADE
- GEN-5 TYPICAL UTILITY LOCATIONS (PUBLIC AND PRIVATE)
- GEN-5A TYPICAL SMALL UTILITY CORRIDORS WITH AND WITHOUT SIDEWALK
- GEN-6 BEDDING METHODS FOR RCP OR DIP
- GEN-7 BEDDING METHODS FOR PVC
- GEN-8 INSULATION DETAIL
- GEN-9 LANDSCAPE STRUCTURES
- GEN-10 ORANGE CONSTRUCTION SAFETY FENCE

SECTION 1 - SANITARY SEWER

- SAN-1 SANITARY SEWER MANHOLE
- SAN-1B SANITARY MANHOLE HDPE PIPE
- SAN-2 SANITARY SEWER JUNCTION MANHOLE
- SAN-3 SANITARY SEWER JUNCTION MANHOLE WITH REINFORCED TOP SLAB
- SAN-4 DROP INLET MANHOLE
- SAN-5 WATERTIGHT CASTING FOR SANITARY SEWER MANHOLE
- SAN-6 WATERTIGHT CASTING FOR FLAT SLAB SANITARY SEWER MANHOLE
- SAN-7 TYPICAL FORCEMAIN INSTALLATION
- SAN-8 SANITARY SEWER DROP INLET MANHOLE PIPES LARGER THAN 12"

SECTION 2 - WATER MAIN

- WAT-1 GATE VALVE AND BOX INSTALLATION
- WAT-2 VALVE AND HYDRANT INSTALLATION
- WAT-3 BUTTERFLY VALVE AND BOX INSTALLATION
- WAT-4 CONCRETE THRUST BLOCKING
- WAT-5 WATER MAIN WET TAP
- WAT-6 WATER MAIN LOWERING WITH INSULATION
- WAT-7 TYPICAL WATER MAIN INSTALLATION
- WAT-8 AIR BLEED INSTALLATION
- WAT-9 DIP TO C900 WATERMAIN TRANSITION FOR TRACER WIRE
- WAT-10 TRACER WIRE FOR PVC WATER MAIN
- WAT-11 CLOW MEDALLION HYDRANT AND VALVE INSTALLATION



2335 Highway 36 W
St. Paul, MN 55113
www.stantec.com

INDEX

CHASKA, MINNESOTA

LAST REVISION:
MARCH 2023

PLATE NO.
GEN-1A

SECTION 3 - SERVICES

- SER-1 SEWER SERVICE CONNECTION
- SER-2 WATER SERVICE CONNECTION
- SER-2A WATER SERVICE CONNECTION
- SER-3 SERVICE RISER
- SER-4 SERVICE LINE CLEANOUTS
- SER-5 VCP SEWER SERVICE CUT-IN
- SER-6 IRRIGATION SERVICE BY PRIVATE CONTRACTOR

SECTION 4 - STORM SEWER

- STO-1 STORM SEWER MANHOLE
- STO-2 STORM SEWER JUNCTION MANHOLE
- STO-3 STORM SEWER JUNCTION MANHOLE WITH REINFORCED TOP SLAB
- STO-4 PERFORATED SUMP MANHOLE
- STO-5 TYPE II CATCH BASIN MANHOLE
- STO-5A TYPE II CATCH BASIN MANHOLE POND SKIMMER
- STO-6 TYPE II CATCH BASIN
- STO-7 DOUBLE CATCH BASIN - TYPE II CBMH WITH TYPE II CB
- STO-8 DOUBLE TYPE II CATCH BASIN
- STO-9 PRECAST 27" SHALLOW DEPTH BEEHIVE
- STO-10 FLARED END SECTION AND TRASH GUARD
- STO-11 RIP RAP AT OUTLETS
- STO-11B GROUTED RIP RAP AT OUTLETS
- STO-12 PERFORATED PVC DRAINTILE PIPE BELOW CONCRETE CURB
- STO-13 PERFORATED PIPE - TRENCH DETAIL
- STO-14 DRAINTILE INSTALLATION INTO CATCH BASIN MANHOLE
- STO-15 PVC SUMP LINE BEHIND CURB
- STO-16 SEEPAGE COLLAR
- STO-17 STANDARD SKIMMER STRUCTURE
- STO-17B SKIMMER STRUCTURE WITH SUBMERGED PIPE
- STO-18 SKIMMER STRUCTURE WITH CAST IN FIELD CONCRETE BAFFLE WALL W/ORIFICE
- STO-18B SKIMMER STRUCTURE WITH CAST IN FIELD CONCRETE BAFFLE WALL
- STO-18C SKIMMER STRUCTURE WITH CAST IN FIELD CONCRETE BAFFLE WALL w/ORIFICE AND SUBMERGED PIPE
- STO-19 TYPICAL POND BENCH DETAIL



2335 Highway 36 W
St. Paul, MN 55113
www.stantec.com

INDEX

CHASKA, MINNESOTA

LAST REVISION:
AUGUST 2023

PLATE NO.
GEN-1B

SECTION 5 - STREETS

- STR-1 CURB AND GUTTER
- STR-1A NON STANDARD CURB AND GUTTER
- STR-2 CONCRETE DRIVEWAY APRON
- STR-3 COMMERCIAL DRIVEWAY
- STR-4 B618 CURB & GUTTER CONSTRUCTION AT CATCH BASIN
- STR-5 SURMOUNTABLE CURB & GUTTER CONSTRUCTION AT CATCH BASIN
- STR-6 TYPICAL SECTIONS FOR RESIDENTIAL STREETS - RURAL
- STR-7 TYPICAL SECTIONS FOR RESIDENTIAL STREETS - 7 TON
- STR-7A TYPICAL SECTIONS FOR RESIDENTIAL STREETS - PRIVATE
- STR-8 TYPICAL SECTION - 9 TON STREET
- STR-9 TYPICAL PLACEMENT AND SECTIONS FOR WALKS AND TRAILS
- STR-10 CONCRETE CURB & GUTTER TRANSITION
- STR-11 PEDESTRIAN CURB RAMP (PATHWAY/SIDEWALK)
- STR-12 TYPICAL SECTION FOR SIDEWALK ACROSS COMMERCIAL DRIVEWAY
- STR-13 MAILBOX INSTALLATION
- STR-14 MEDIAN SIGN INSTALLATION DETAIL
- STR-15 STOP SIGN INSTALLATION DETAIL
- STR-16 TYPICAL STREET COMPONENTS/DIMENSIONS
- STR-17 TEMPORARY BITUMINOUS CUL-DE-SAC

SECTION 6 - EROSION CONTROL

- ERO-1A SILT FENCE - MACHINE SLICED
- ERO-1B SILT FENCE - HEAVY DUTY
- ERO-1C SILT FENCE - STANDARD
- ERO-1D SILT FENCE - J-HOOK
- ERO-2 EROSION CONTROL BLANKET INSTALLATION
- ERO-3A FLOATING SILT CURTAIN IN MOVING WATER
- ERO-3B FLOATING SILT CURTAIN IN STILL WATER
- ERO-4A INLET PROTECTION - FOR CATCH BASIN BEFORE CURB CONSTRUCTION
- ERO-4B INLET PROTECTION - FOR CATCH BASIN AFTER CURB CONSTRUCTION
- ERO-4C INLET PROTECTION - FOR BEEHIVE CASTING
- ERO-5 DITCH CHECK / WEEPER SIZING AND MATERIALS
- ERO-6 FLARED END EROSION CONTROL
- ERO-7 ROCK CONSTRUCTION ENTRANCE
- ERO-8A TEMPORARY SEDIMENTATION BASIN - PIPE OUTLET
- ERO-8B TEMPORARY SEDIMENT BASIN - STANDPIPE OUTLET
- ERO-9 TEMPORARY SEDIMENT TRAP
- ERO-10 SLOPE TRACKING
- ERO-11 EROSION CONTROL FOR LOT GRADING
- ERO-12 CONCRETE WASHOUT PIT
- ERO-13 TURF REINFORCEMENT MAT POND OVERFLOW
- ERO-14 TURF REINFORCEMENT MAT ON SLOPE



2335 Highway 36 W
St. Paul, MN 55113
www.stantec.com

INDEX

CHASKA, MINNESOTA

LAST REVISION:
MAY 2023

PLATE NO.
GEN-1C

SECTION 7 - SITE GRADING

- GRD-1 REQUIRED LOT GRADING INFORMATION
- GRD-2 REQUIRED LOT GRADING INFORMATION
- GRD-3 REQUIRED LOT GRADING INFORMATION
- GRD-4 REQUIRED LOT GRADING INFORMATION
- GRD-5 EMERGENCY OVERFLOW INFORMATION

SECTION 8 - ELECTRICAL

- ELC-01 LIGHT POLE ANCHORAGE GUIDE AND LOCATION
- ELC-01A BANNER POLE ANCHORAGE GUIDE

SECTION 9 - MISCELLANEOUS

- MIS-1A WASTEWATER PUMPING STATION
- MIS-1B WASTEWATER PUMPING STATION
- MIS-1C WASTEWATER PUMPING STATION



2335 Highway 36 W
St. Paul, MN 55113
www.stantec.com

INDEX

CHASKA, MINNESOTA



















LAST REVISION:
APRIL 2018

PLATE NO.
GEN-1D

<u>ITEM</u>	<u>TEMPLATE</u> *	<u>PEN</u>
STREET TITLES	350	4
SIDE STREET NAMES	240	2
ADDITION NAMES	200	2
BLOCK NUMBERS	175	1
LOT NUMBERS	140	1
LOT DIMENSIONS	100	00
ROW DIMENSIONS	120	0
ALL PLAN NOTES	120	0
ALL PROFILE NOTES	120	0
PROFILE ELEVATIONS AND STATIONING	175	2
CENTERLINE STATIONING	80	000
BENCH MARK	175	1

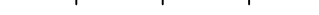
* 50 SCALE

<u>TITLE BLOCKS</u>		
PROJECT NAME	175	2
COMM. OR PROJECT NO. AND DATE	120	0
TITLE BLOCK	120	0
SHEET NUMBERING	120	0

<u>ITEM</u>	<u>PEN SIZE</u>	<u>PEN SIZE</u>
PLAT BOUNDARIES	0	
ROW LINES	0	
LOT LINES	00	
ROW CENTER LINES	000	
CURB AND GUTTER	000	
EXISTING CENTER LINE PROFILE	PENCIL	
PROPOSED CENTER LINE PROFILE	00	
BOUNDARY LINE - COUNTY	3	
BOUNDARY LINE - CITY	2	
SECTION LINE	00	
QUARTER SECTION LINE	00	
SIXTEENTH SECTION LINE	00	
SANITARY SEWER	2	
WATER MAIN	1	
STORM SEWER	1	
CROSS SECTION - EXISTING	00	
CROSS SECTION - PROPOSED	PENCIL	
CROSS SECTION - SUBGRADE	PENCIL	
DIMENSIONING LEADER LINES	00	
DIMENSION LINES	00	



2335 Highway 36 W
 St. Paul, MN 55113
 www.stantec.com

DRAFTING GUIDELINES

CHASKA, MINNESOTA

LAST REVISION:
MAY 2023

PLATE NO.
GEN-2

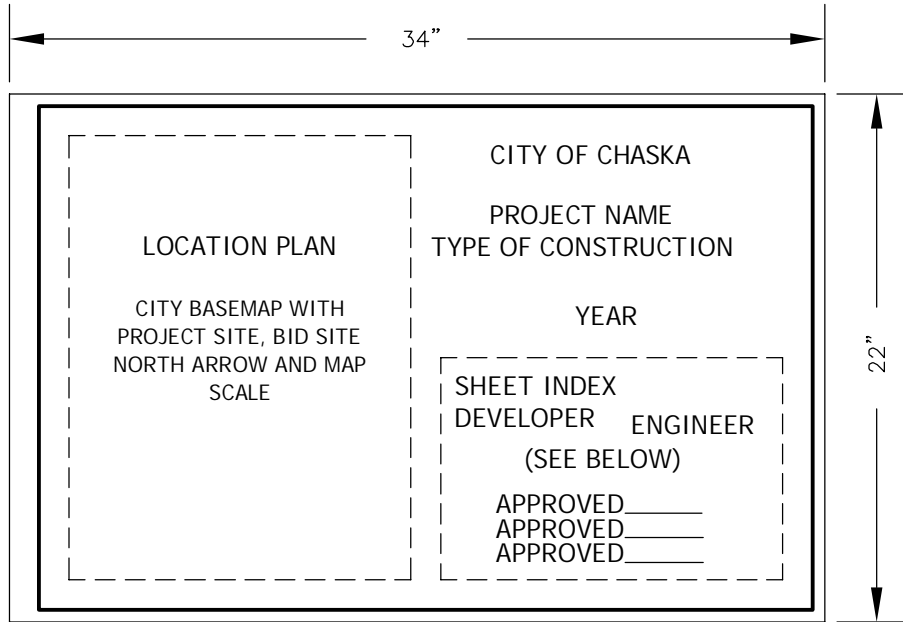

<p>SHEET INDEX</p> <ol style="list-style-type: none"> 1. TITLE SHEET 2. 3. 4. 5. 6. 7. 	<p>DEVELOPER</p> <p>NAME _____</p> <p>ADDRESS _____</p> <p>PHONE _____</p> <p>ENGINEER</p> <p>NAME _____</p> <p>ADDRESS _____</p> <p>PHONE _____</p>
<p>APPROVED _____ DATE ____ 20 ____</p> <p style="text-align: center;">CHASKA CITY ENGINEER</p>	
<p>APPROVED _____ DATE ____ 20 ____</p> <p style="text-align: center;">CHASKA MUNICIPAL SERVICES</p>	
<p>APPROVED _____ DATE ____ 20 ____</p> <p style="text-align: center;">CHASKA PLANNING DEPARTMENT</p>	



2335 Highway 36 W
 St. Paul, MN 55113
 www.stantec.com

STANDARD PROJECT COVER SHEET

CHASKA, MINNESOTA

LAST REVISION:
 MAY 2023

PLATE NO.
 GEN-3

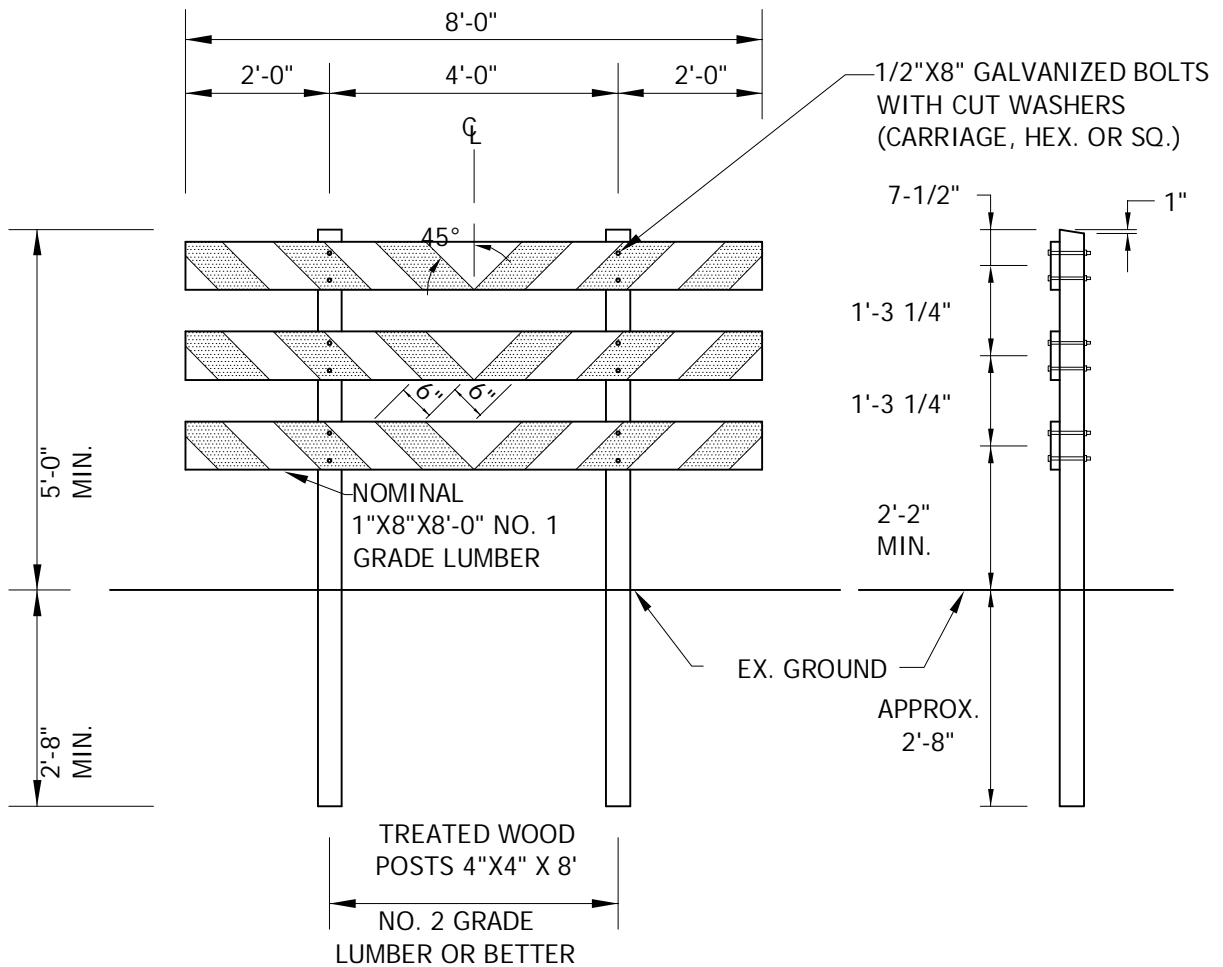

NOTE

THE BARRICADE BOARD FACE SURFACES SHALL BE FULLY REFLECTORIZED IN ALTERNATE SILVER-WHITE AND RED STRIPING, USING A REFLECTIVE SHEETING CONFORMING TO THE REQUIREMENTS OF MNDOT SPEC. 3352.

PRIOR TO INSTALLING THE REFLECTIVE SHEETING, THE BARRICADE BOARDS SHALL BE GIVEN A COMPLETE COATING OF WHITE WOOD PRIMER PAINT FOLLOWED BY A SECOND COAT OF WHITE EXTERIOR APPLIED ONLY TO THE SURFACES NOT COVERED WITH REFLECTIVE SHEETING.

THE BARRICADE BOARDS SHALL BE COMPLETELY PAINTED AND REFLECTORIZED SHEETING APPLIED BEFORE BEING INSTALLED ON THE POSTS.

THE PLACEMENT OF THE BARRICADE SHALL BE 10'-0" FROM THE END OF THE BITUMINOUS ROAD WITH THE BARRICADE CENTERED ON THE ROADWAY FACING THE FLOW OF TRAFFIC.



2335 Highway 36 W
 St. Paul, MN 55113
 www.stantec.com

PERMANENT BARRICADE

CHASKA, MINNESOTA

LAST REVISION:
 MARCH 2008

PLATE NO.
 GEN-4



TYPICAL STREET LIGHT LOCATION

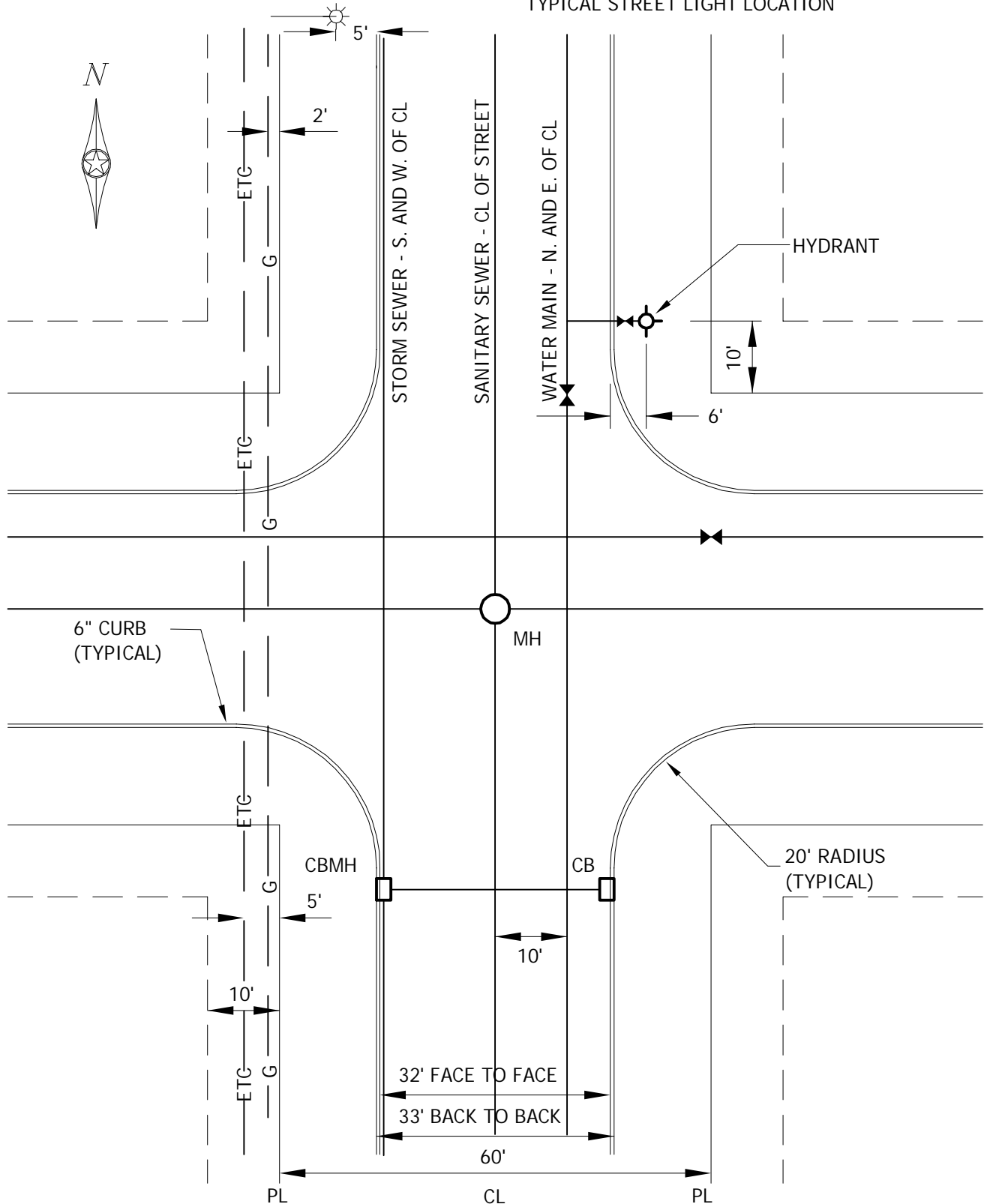

2335 Highway 36 W
 St. Paul, MN 55113
 www.stantec.com

TYPICAL UTILITY LOCATIONS
 (PUBLIC AND PRIVATE)

CHASKA, MINNESOTA

LAST REVISION:
 MARCH 2016

PLATE NO.
 GEN-5

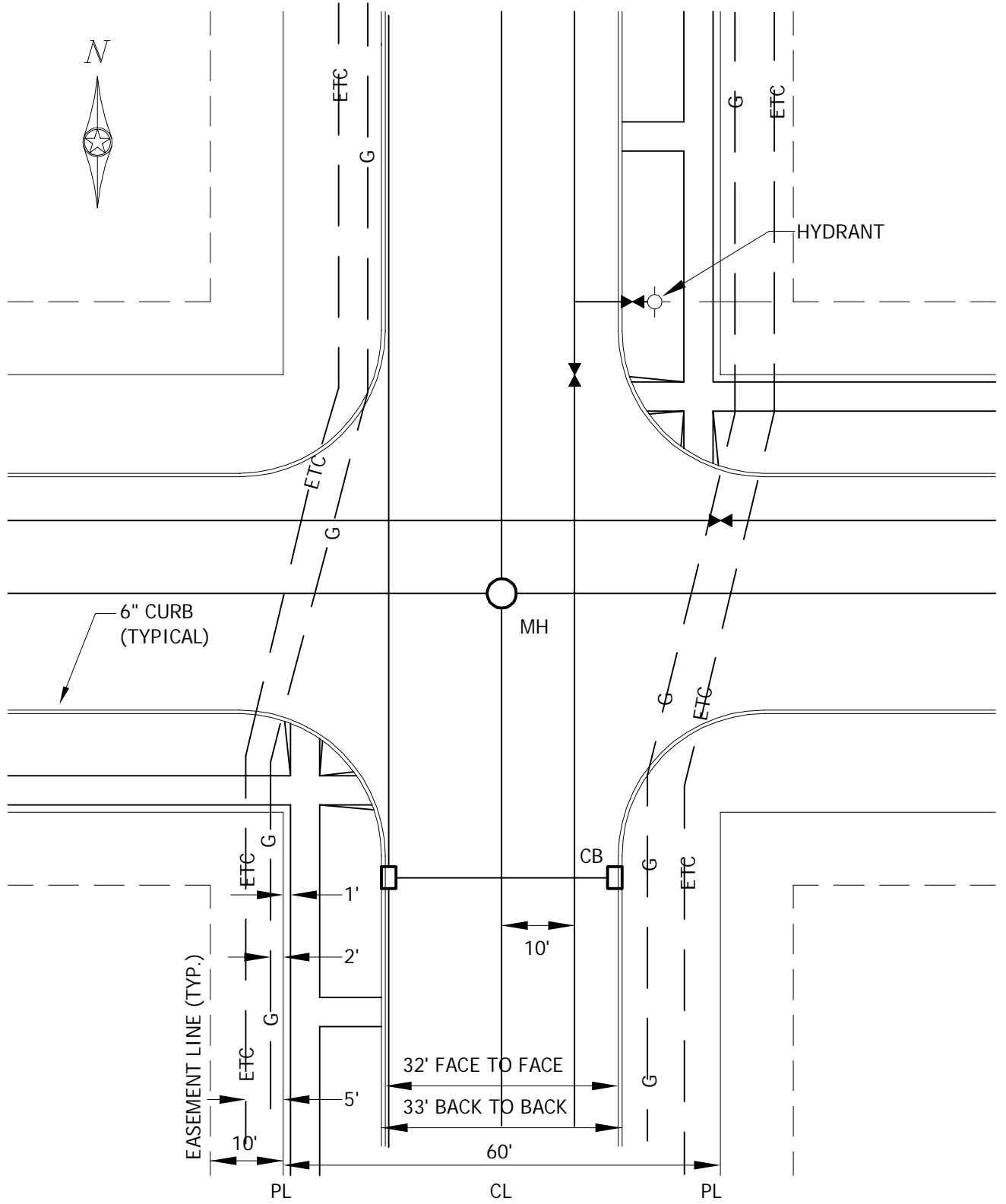

TYPICAL SMALL UTILITY CORRIDORS
 WITH AND WITHOUT SIDEWALK

CHASKA, MINNESOTA

LAST REVISION:
 MARCH 2016

PLATE NO.
 GEN-5A

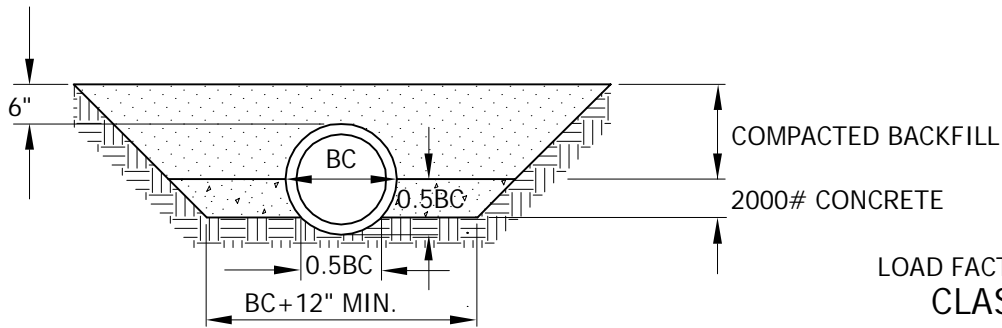

LOAD FACTOR 2.3
CLASS A
 CONCRETE BACKFILL TO 0.5
 OF OUTSIDE DIAMETER WITH
 SHAPED BEDDING.

"BC" DENOTES OUTSIDE
DIAMETER OF PIPE

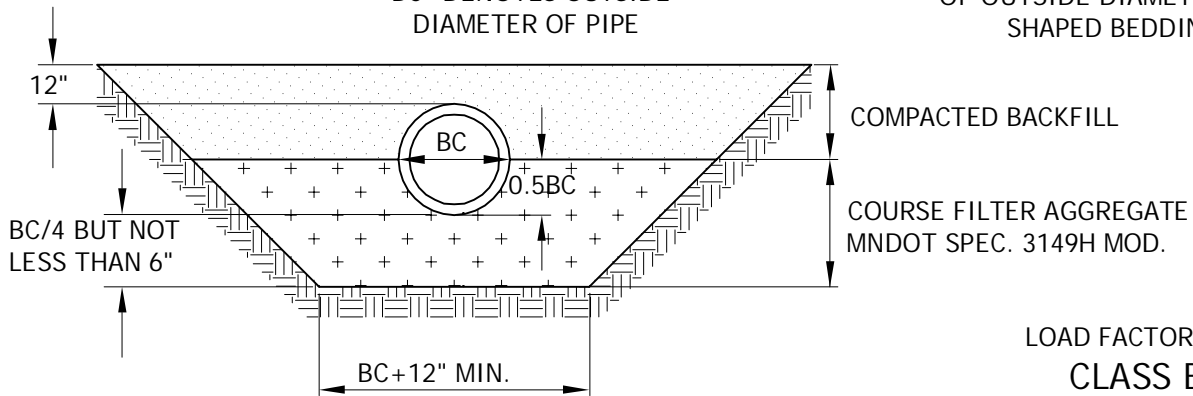

LOAD FACTOR 1.9
CLASS B
 HAND SHAPED FROM
 ANGULAR BEDDING MATERIAL

"BC" DENOTES OUTSIDE
DIAMETER OF PIPE

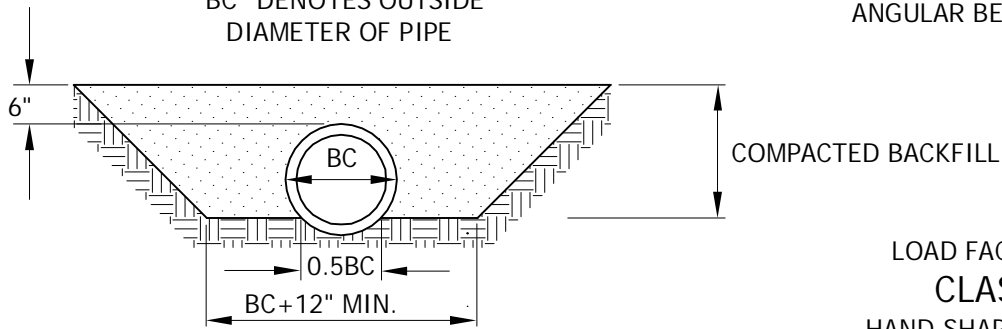

LOAD FACTOR 1.5
CLASS C-1
 HAND SHAPED FROM FIRM
 UNDISTURBED SOIL

"BC" DENOTES OUTSIDE
DIAMETER OF PIPE

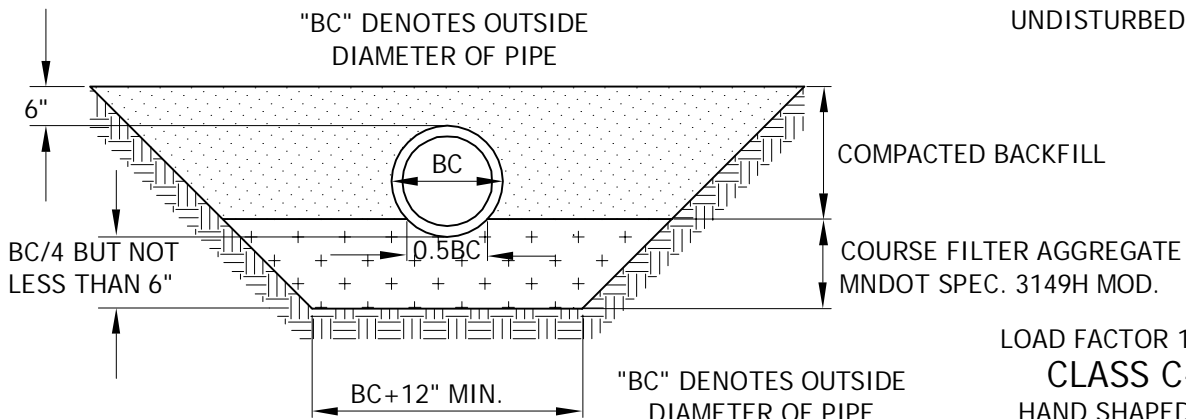

LOAD FACTOR 1.5
CLASS C-2
 HAND SHAPED FROM
 ANGULAR BEDDING MATERIAL

"BC" DENOTES OUTSIDE
DIAMETER OF PIPE



2335 Highway 36 W
 St. Paul, MN 55113
 www.stantec.com

BEDDING METHODS FOR RCP OR DIP

CHASKA, MINNESOTA

LAST REVISION:
 MARCH 2001

PLATE NO.
GEN-6

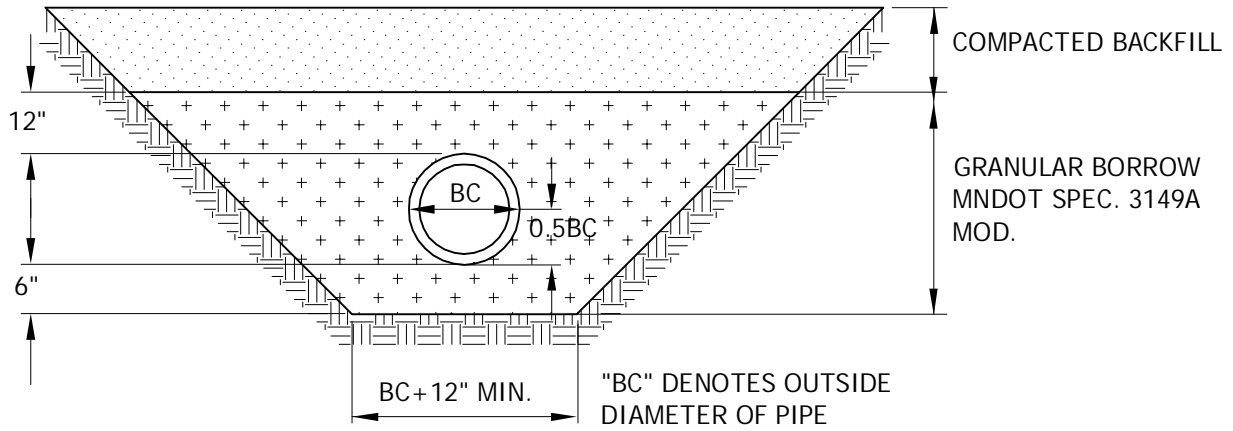

PIPE FOUNDATION & BEDDING IN GOOD SOILS

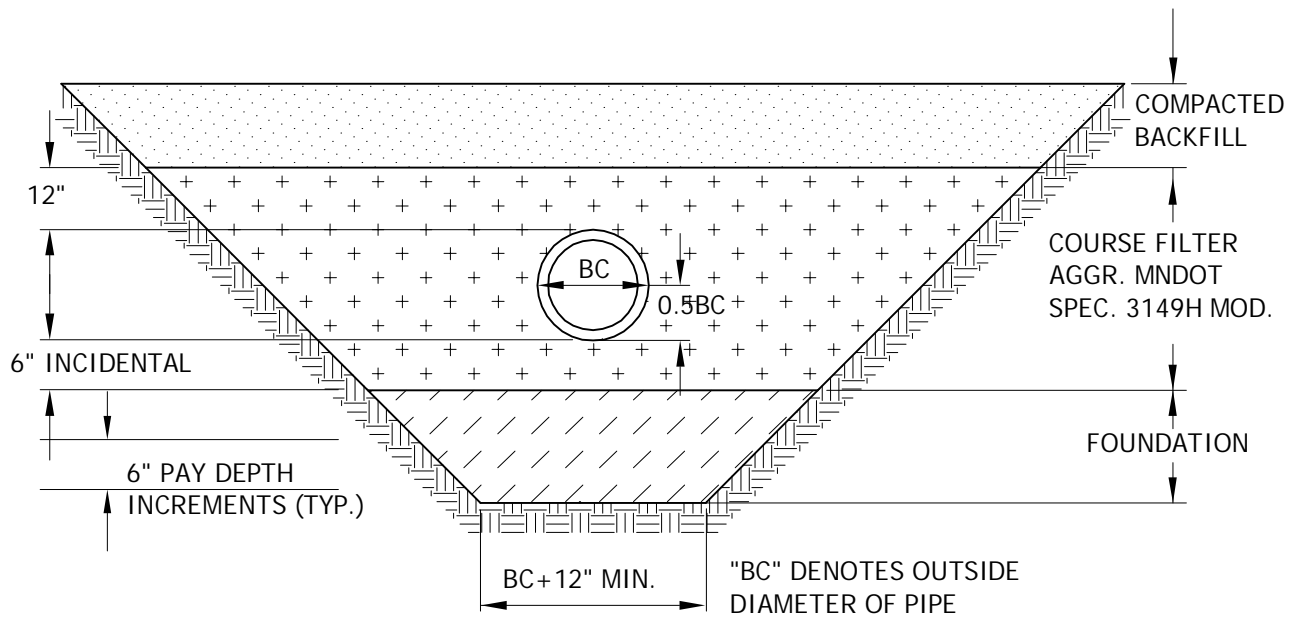

IMPROVED PIPE FOUNDATION & BEDDING IN POOR SOILS



2335 Highway 36 W
St. Paul, MN 55113
www.stantec.com

BEDDING METHODS FOR PVC

CHASKA, MINNESOTA

LAST REVISION:
MARCH 2008

PLATE NO.
GEN-7

NOTE: WATER MAIN BURIED LESS THAN 7.5' TO BE APPROVED BY OWNER

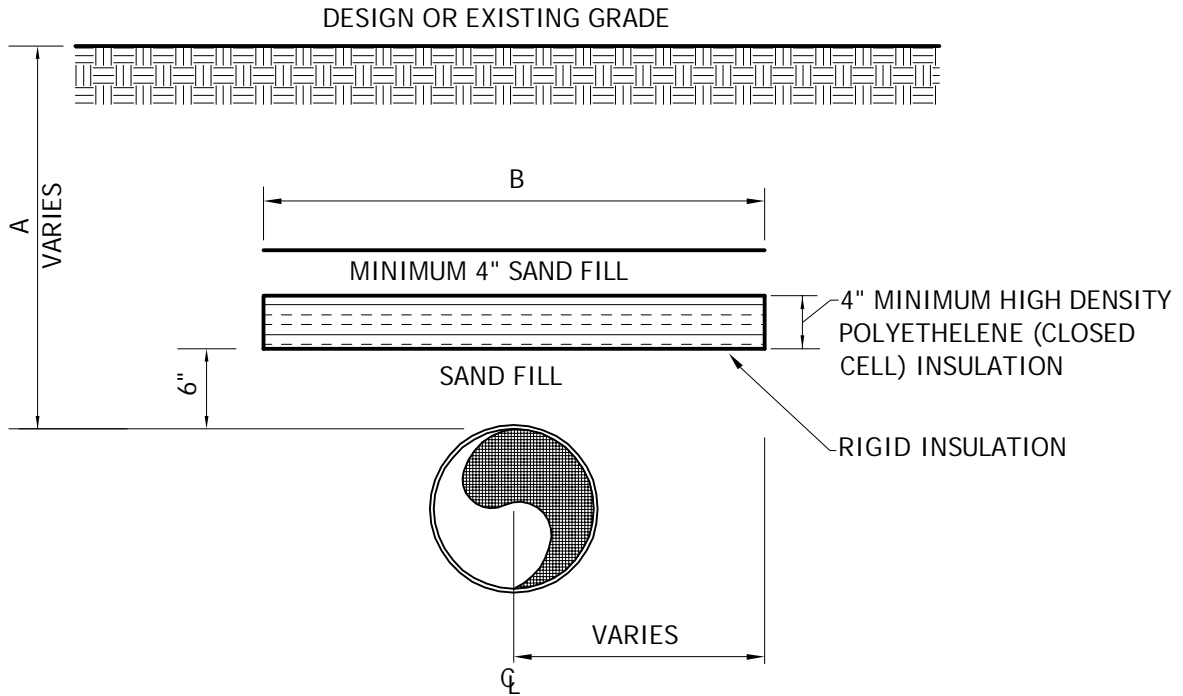

NOTE: PIPE SHALL BE CENTERED UNDER INSULATION UNLESS OTHERWISE SPECIFIED. STAGGER/ OFFSET JOINTS 2' MINIMUM BETWEEN SHEET LAYERS.

<u>COVER OVER PIPE - A</u>	<u>WIDTH OF INSULATING BOARD - B</u>
2'	11'
3'	9'
4'	7'
5'	5'
6'	3'



2335 Highway 36 W
 St. Paul, MN 55113
 www.stantec.com

INSULATION DETAIL
 CHASKA, MINNESOTA

LAST REVISION:
 APRIL 2016

PLATE NO.
 GEN-8

NOTE: ALL PLANTERS TO BE UNIFORM AND HAVE SMOOTH FORM FINISH VERTICAL FACE.

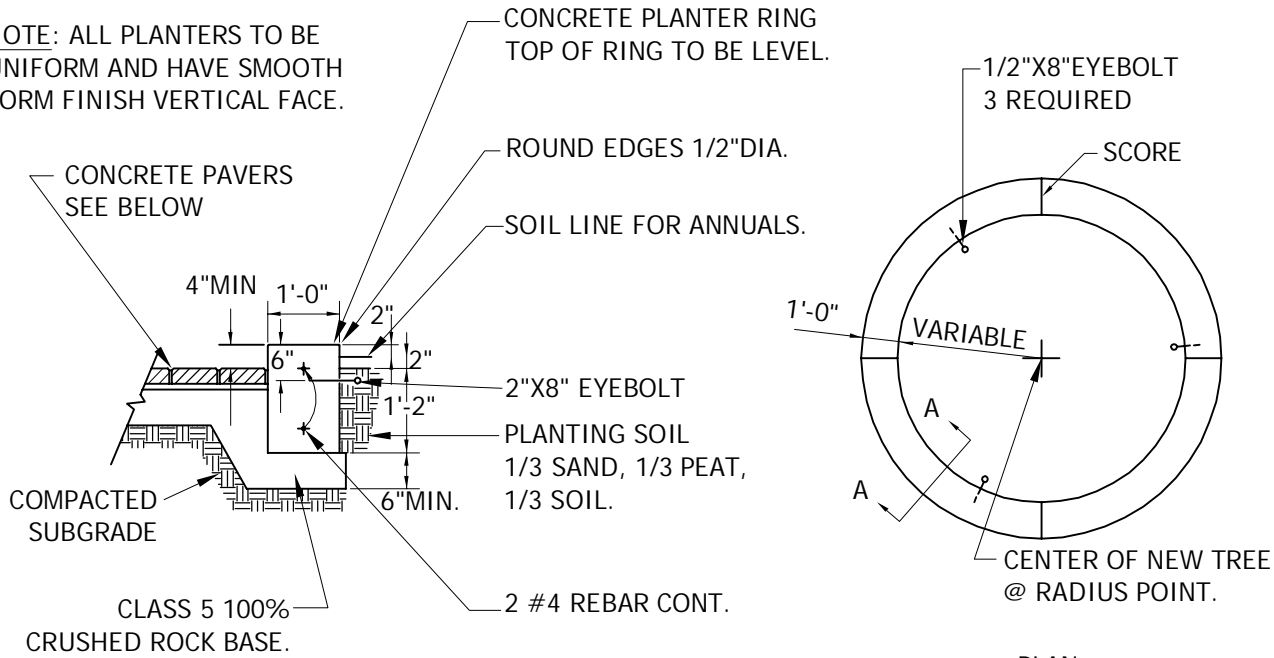

SECTION

PLAN

CONCRETE PLANTER
NO SCALE

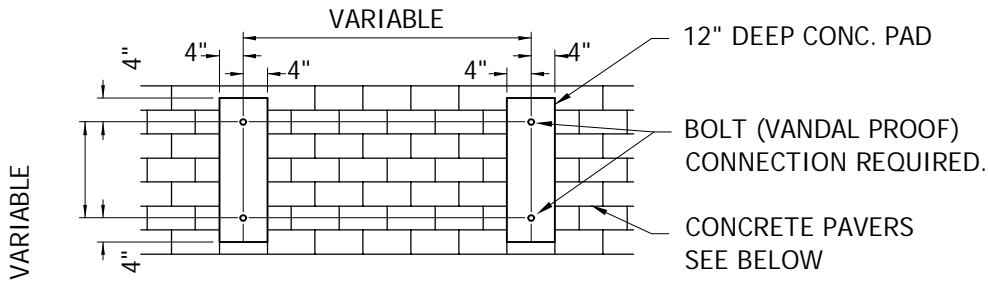

BENCH PAD PLAN
NO SCALE

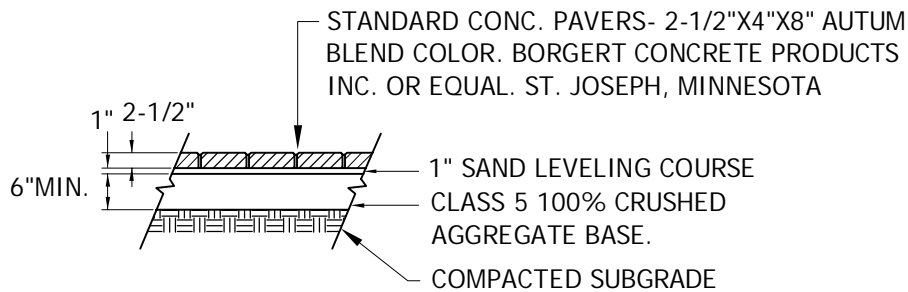

CONCRETE PAVERS
NO SCALE



2335 Highway 36 W
 St. Paul, MN 55113
 www.stantec.com

LANDSCAPE STRUCTURES

CHASKA, MINNESOTA

LAST REVISION:
 MARCH 2001

PLATE NO.
 GEN-9

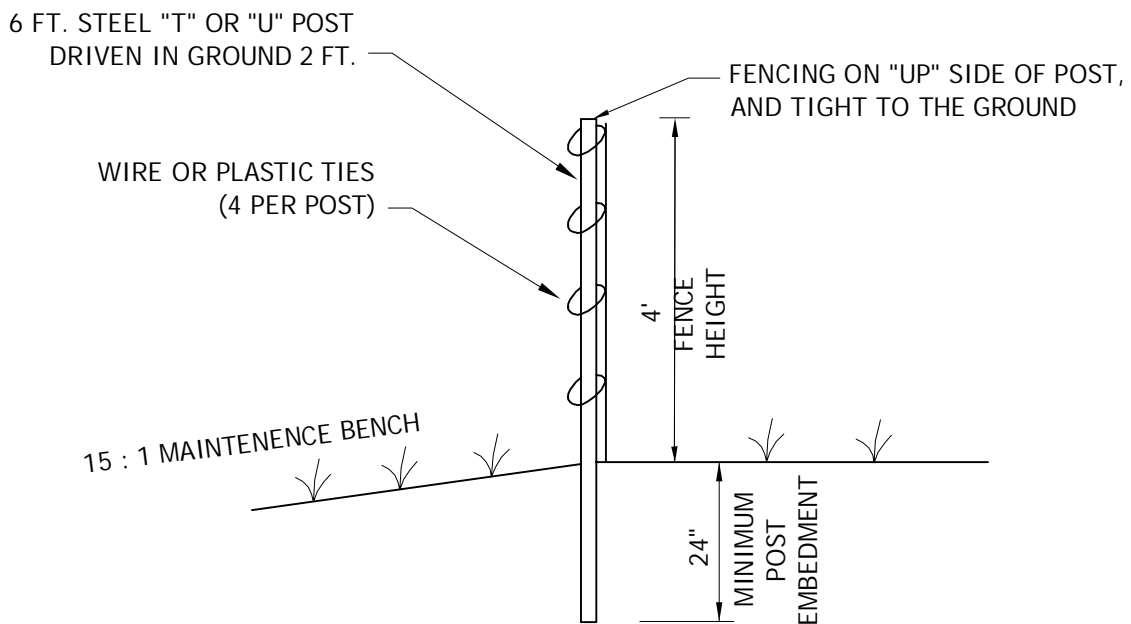
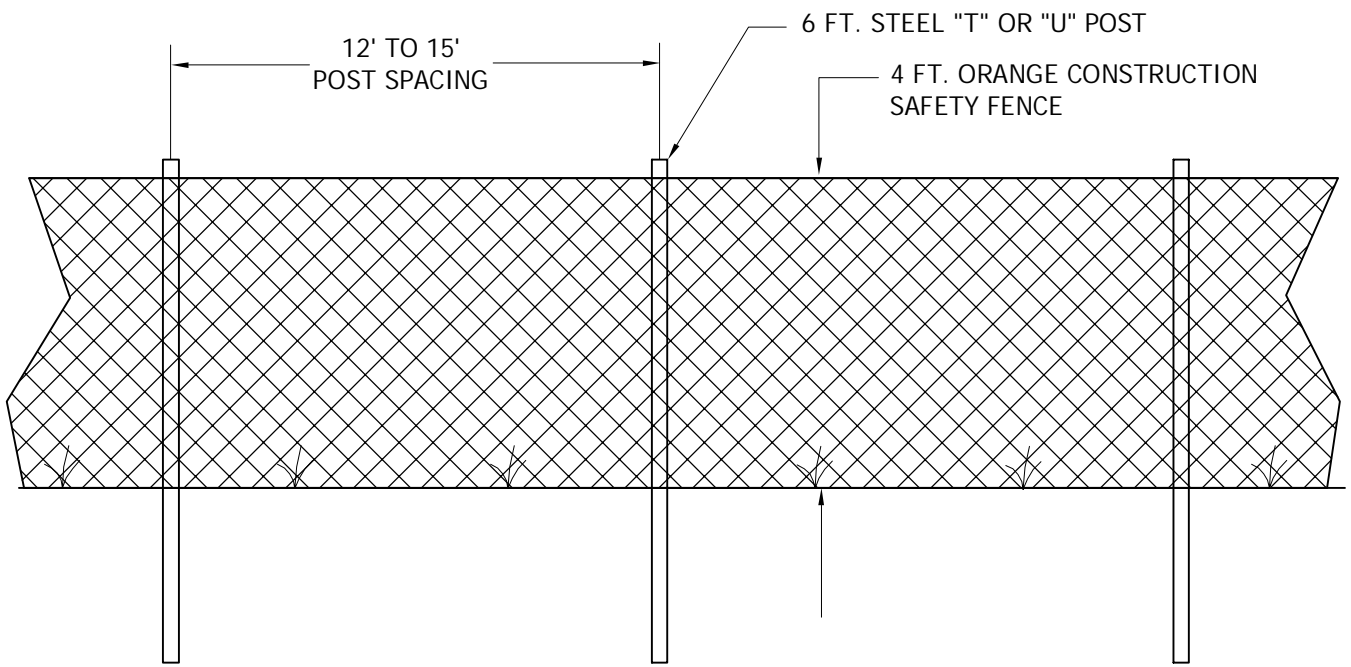

2335 Highway 36 W
St. Paul, MN 55113
www.stantec.com

ORANGE CONSTRUCTION SAFETY FENCE

CHASKA, MINNESOTA

LAST REVISION:
MARCH 2001

PLATE NO.
GEN-10

Plot Date: 03/28/2023
 Plotting Name: R:\chaska\plans\23\Chaska\2023 Detail Plates\SAN-1.dwg
 Xref:

PRECAST INVERT WITH A MINIMUM 1% THROUGH SLOPE REQUIRED.

PRECAST INVERT MUST BE 1/2 DIAMETER OF THE PIPE AND BENCHES SLOPED 2" TOWARD THE INVERT.

FRAME	A	B
R1642-2310B	27"	7"
R1755G	27"	7"

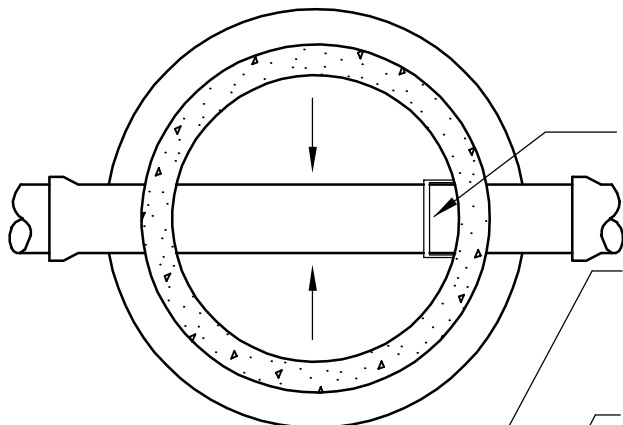

PLAN

MANHOLE STEPS SHALL BE PLACED SO THAT OFFSET VERTICAL PORTION OF CONE IS FACING DOWNSTREAM.

NEENAH COVER R-1642-5001, LETTERED "SANITARY SEWER" WITH 2 CONCEALED PICK HOLES AND SELF SEALING LID. SEE SPECIFICATION FOR CASTING NUMBER.

MINIMUM OF 2 MAXIMUM OF 4 ADJUSTMENT RINGS. FINAL RING MATERIAL AND ADHESIVE TO BE SPECIFIED BY OWNER ON A PROJECT BASIS.

MAXIMUM 20" ADJUSTMENT ALLOWED INCLUDING RINGS AND CASTING.

INSTALL I&I BARRIER BY STRIKE PRODUCTS OR APPROVED EQUAL.

MANHOLE STEPS, COPOLYMER POLYPROPYLENE PLASTIC, WITH 1/2" GRADE 60 STEEL REINFORCEMENT OR EQUAL, 16" ON CENTER. (NO STEPS ALLOWED IN UPPER 27" BARREL)

ALL JOINTS IN MANHOLE TO HAVE SELF LUBRICATING RUBBER GASKETS, RAMNECK, AND GATOR WRAP.

NOTE: ALL INFILTRATION AREAS SHALL BE REPAIRED UNTIL MANHOLE IS WATER TIGHT.

PIPE SHALL BE CUT 2" FROM INSIDE FACE OF WALL.

.1' DROP ACROSS INVERTS MIN.

NOTE: KOR-N-SEAL MANHOLE TO BE USED FOR PIPE / MANHOLE CONNECTION.

ALL DOG HOUSES SHALL BE GROUTED ON INSIDE OF MANHOLE.

COMPACT TO TOP OF PIPE, TO FIRST JOINT.

MINIMUM THICKNESS OF PRECAST BASE IS 6" FOR 14' DEEP OR LESS, AND INCREASES 1" IN THICKNESS FOR EVERY 4' OF DEPTH GREATER THAN 14'.

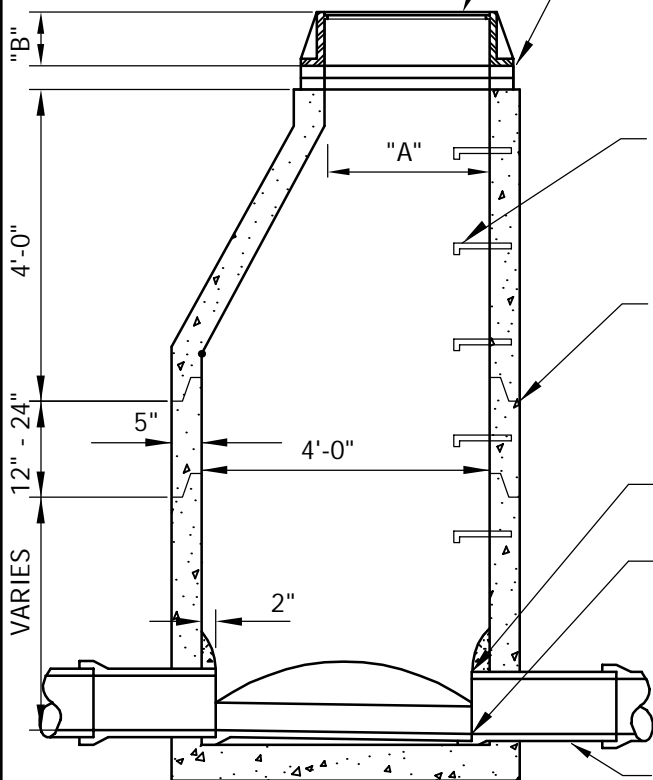

SECTION

OUTER SURFACE OF ALL PRE-CAST SECTIONS SHALL RECEIVE 2 COATS OF BITUMINOUS DAMP PROOFING (SEE ENGINEERING GUIDELINES OR PROJECT SPECIFICATIONS FOR MORE DETAILS).



2335 Highway 36 W
 St. Paul, MN 55113
 www.stantec.com

SANITARY SEWER MANHOLE

CHASKA, MINNESOTA

LAST REVISION:
 MARCH 2023

PLATE NO.
 SAN-1

Plot Date: 03/28/2023
 Plotting Name: R:\chaska\plans\2023\Chaska\2023 Detail Plates\SAN-1B.dwg
 Xref:

PRECAST INVERT WITH A MINIMUM 1% THROUGH SLOPE REQUIRED.

PRECAST INVERT MUST BE 1/2 DIAMETER OF THE PIPE AND BENCHES SLOPED 2" TOWARD THE INVERT.

FRAME	A	B
R1642-2310B	27"	7"
R1755G	27"	7"

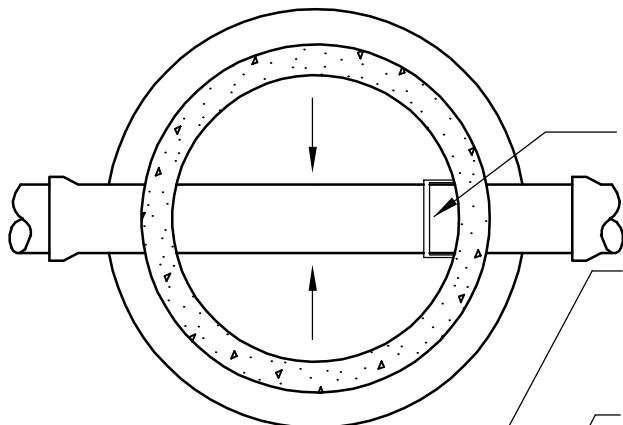

PLAN

MANHOLE STEPS SHALL BE PLACED SO THAT OFFSET VERTICAL PORTION OF CONE IS FACING DOWNSTREAM.

NEENAH COVER R-1642-5001, LETTERED "SANITARY SEWER" WITH 2 CONCEALED PICK HOLES AND SELF SEALING LID. SEE SPECIFICATION FOR CASTING NUMBER.

MINIMUM OF 2 MAXIMUM OF 4 ADJUSTMENT RINGS. FINAL RING MATERIAL AND ADHESIVE TO BE SPECIFIED BY OWNER ON A PROJECT BASIS.

MAXIMUM 20" ADJUSTMENT ALLOWED INCLUDING RINGS AND CASTING.

INSTALL I&I BARRIER BY STRIKE PRODUCTS OR APPROVED EQUAL.

MANHOLE STEPS, COPOLYMER POLYPROPYLENE PLASTIC, WITH 1/2" GRADE 60 STEEL REINFORCEMENT OR EQUAL, 16" ON CENTER. (NO STEPS ALLOWED IN UPPER 27" BARREL)

ALL JOINTS IN MANHOLE TO HAVE SELF LUBRICATING RUBBER GASKETS, RAMNECK AND GATOR WRAP.

NOTE: ALL INFILTRATION AREAS SHALL BE REPAIRED UNTIL MANHOLE IS WATER TIGHT.

PIPE SHALL BE CUT 2" FROM INSIDE FACE OF WALL. CUT AND REMOVE TOP PORTION OF PIPE.

.1' DROP ACROSS INVERTS (MIN.)

NOTE: KOR-N-SEAL MANHOLE TO BE USED FOR PIPE / MANHOLE CONNECTION.

ALL DOG HOUSES SHALL BE GROUTED ON INSIDE OF MANHOLE.

COMPACT TO TOP OF PIPE.

MINIMUM THICKNESS OF PRECAST BASE IS 6" FOR 14' DEEP OR LESS, AND INCREASES 1" IN THICKNESS FOR EVERY 4' OF DEPTH GREATER THAN 14'.

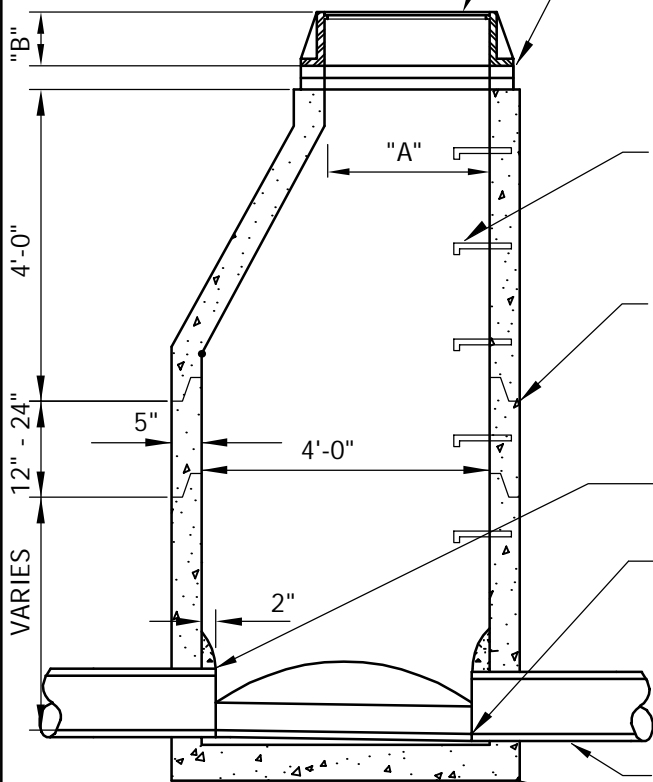

SECTION

OUTER SURFACE OF ALL PRE-CAST SECTIONS SHALL RECEIVE 2 COATS OF BITUMINOUS DAMP PROOFING (SEE ENGINEERING GUIDELINES OR PROJECT SPECIFICATIONS FOR MORE DETAILS).



2335 Highway 36 W
 St. Paul, MN 55113
 www.stantec.com

SANITARY SEWER MANHOLE
 HDPE PIPE
 CHASKA, MINNESOTA

LAST REVISION:
 MARCH 2023

PLATE NO.
 SAN-1B

Plot Date: 10/28/2023
 Drawing Name: R:\csd\mha\p\p\1922 Chaska\102023 Detail Plates\SAN-2.dwg
 Xref:

PRECAST INVERT WITH A MINIMUM 1% THROUGH SLOPE REQUIRED.

PRECAST INVERT MUST BE 1/2 DIAMETER OF THE PIPE AND BENCHES SLOPED 2" TOWARD THE INVERT.

OUTER SURFACE OF ALL PRE-CAST SECTIONS SHALL RECEIVE 2 COATS OF BITUMINOUS DAMP PROOFING (SEE ENGINEERING GUIDELINES OR PROJECT SPECIFICATIONS FOR MORE DETAILS).

FRAME	A	B
R16420245	27"	7"
R1755G	27"	7"

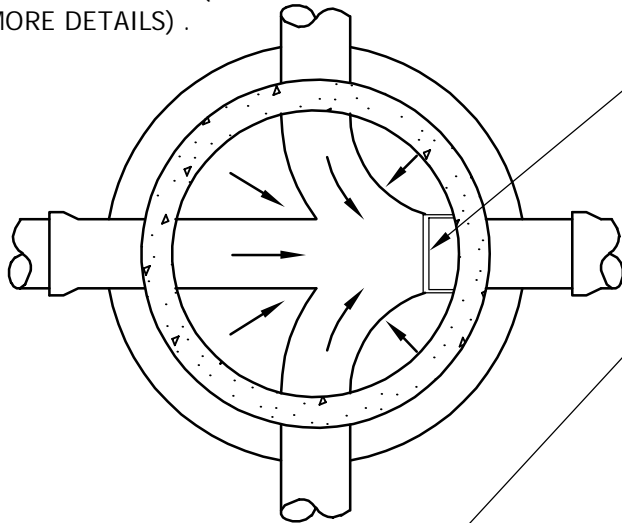

MANHOLE STEPS SHALL BE PLACED SO THAT OFFSET VERTICAL PORTION OF CONE IS FACING DOWNSTREAM.

NEENAH COVER R1642-5001, LETTERED "SANITARY SEWER" WITH 2 CONCEALED PICK HOLES AND SELF SEALING LID. SEE SPECIFICATIONS FOR CASTING NUMBER

MINIMUM OF 2 MAXIMUM OF 4 ADJUSTING RINGS. FINAL RING MATERIAL AND ADHESIVE TO BE SPECIFIED BY OWNER ON A PROJECT BASIS.

MAXIMUM 20" ADJUSTMENT ALLOWED INCLUDING RINGS AND CASTING
 INSTALL I&I BARRIER BY STRIKE PRODUCTS OR APPROVED EQUAL.

ALL JOINTS IN MANHOLE TO HAVE SELF LUBRICATING RUBBER GASKETS, RAMNECK AND GATOR WRAP.

NOTE: ALL INFILTRATION AREAS SHALL BE REPAIRED UNTIL MANHOLE IS WATER TIGHT.

PIPE SHALL BE CUT OUT 2" FROM INSIDE FACE OF WALL.

.1' DROP ACROSS INVERTS (MIN.)

NOTE: KOR-N-SEAL MANHOLE TO BE USED FOR PIPE / MANHOLE CONNECTION.

ALL DOG HOUSES SHALL BE GROUTED ON INSIDE OF MANHOLE.

MINIMUM THICKNESS OF PRECAST BASE IS 6" FOR 14' DEEP OR LESS, AND INCREASES 1" IN THICKNESS FOR EVERY 4' OF DEPTH GREATER THAN 14'.

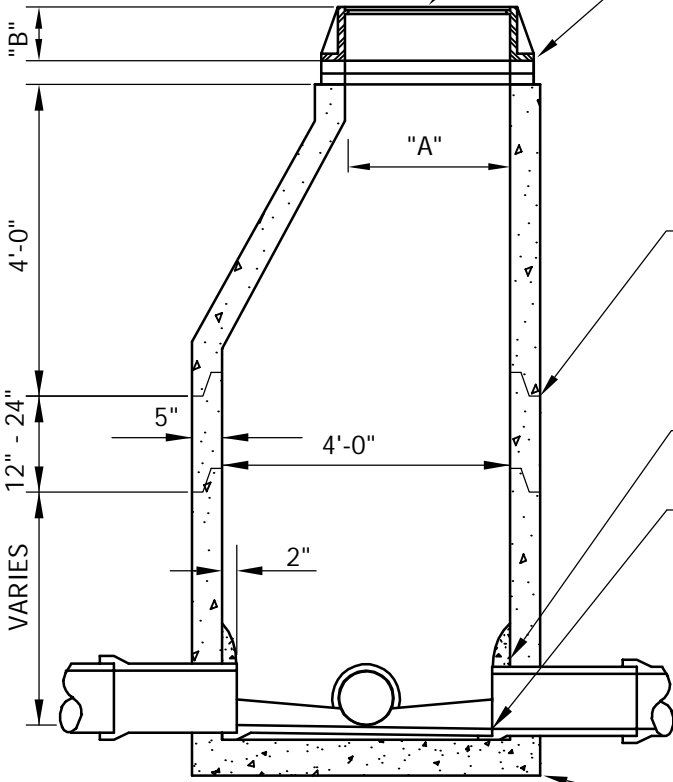

SECTION



2335 Highway 36 W
 St. Paul, MN 55113
 www.stantec.com

SANITARY SEWER JUNCTION MANHOLE

CHASKA, MINNESOTA

LAST REVISION:
 MARCH 2023

PLATE NO.
 SAN-2

Plot Date: 03/28/2023
 Plotting Name: R:\chaska\plates\02 Chaska\2023 Detail Plates\SAN-3.dwg
 Xref:

PRECAST INVERT WITH A MINIMUM 1% THROUGH
 SLOPE REQUIRED.
 PRECAST INVERT MUST BE 1/2 DIAMETER OF THE PIPE
 AND BENCHES SLOPED 2" TOWARD THE INVERT.

FRAME	A	B
R1642-2310B	27"	7"
R1755G	27"	7"

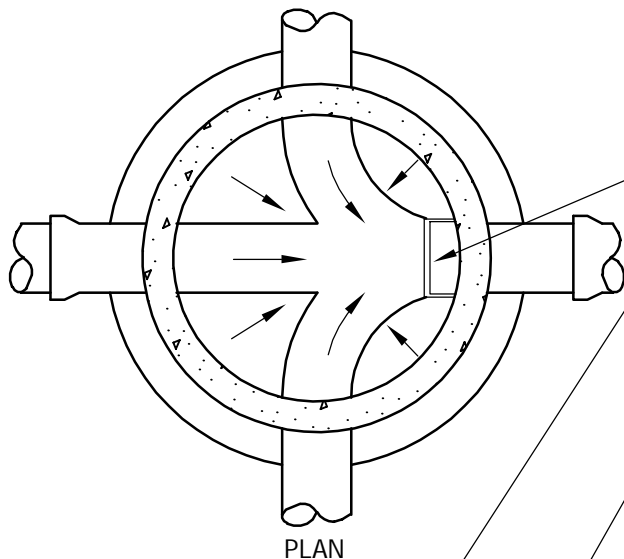

PLAN

OUTER SURFACE OF ALL PRE-CAST SECTIONS
 SHALL RECEIVE 2 COATS OF BITUMINOUS DAMP
 PROOFING (SEE ENGINEERING GUIDELINES OR
 PROJECT SPECIFICATIONS FOR MORE DETAILS).

MANHOLE STEPS SHALL BE PLACED
 SO THAT OFFSET VERTICAL PORTION
 OF CONE IS FACING DOWNSTREAM.

NEENAH COVER R1642-5001, LETTERED
 "SANITARY SEWER", WITH 2 CONCEALED PICK
 HOLES AND SELF SEALING LID. SEE
 SPECIFICATION FOR CASTING NUMBER.

MINIMUM OF 2 MAXIMUM OF 4 ADJUSTMENT
 RINGS. FINAL RING MATERIAL AND ADHESIVE
 TO BE SPECIFIED BY OWNER ON A PROJECT
 BASIS.

MAXIMUM 20" ADJUSTMENT ALLOWED
 INCLUDING RINGS AND CASTING.
 INSTALL I&I BARRIER BY STRIKE PRODUCTS
 OR APPROVED EQUAL.

MANHOLE STEPS, COPOLYMER POLYPROPYLENE
 PLASTIC, WITH 1/2" GRADE 60 STEEL
 REINFORCEMENT OR EQUAL, 16" ON CENTER.
 (NO STEPS ALLOWED IN TOP SLAB.)

ALL JOINTS IN MANHOLE TO HAVE SELF
 LUBRICATING RUBBER GASKETS, RAMNECK,
 AND GATOR WRAP.

NOTE: ALL INFILTRATION AREAS SHALL BE
 REPAIRED UNTIL MANHOLE IS WATER TIGHT.

PIPE SHALL BE CUT OUT 2" FROM
 INSIDE FACE OF WALL.

.1' DROP ACROSS INVERTS (MIN.)

NOTE: KOR-N-SEAL MANHOLE TO BE USED
 FOR PIPE / MANHOLE CONNECTION.

ALL DOG HOUSES SHALL BE GROUTED
 ON INSIDE OF MANHOLE.

MINIMUM THICKNESS OF PRECAST BASE IS 6"
 FOR 14' DEEP OR LESS, AND INCREASES 1" IN
 THICKNESS FOR EVERY 4' OF DEPTH GREATER
 THAN 14'.

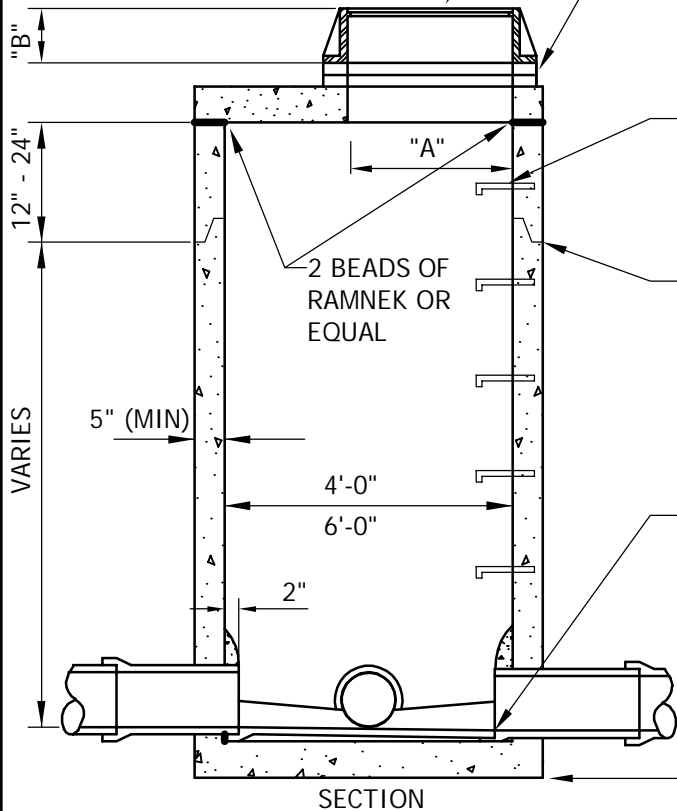

SECTION



2335 Highway 36 W
 St. Paul, MN 55113
 www.stantec.com

**SANITARY SEWER JUNCTION MANHOLE
 WITH REINFORCED TOP SLAB**

CHASKA, MINNESOTA

LAST REVISION:
 MARCH 2023

PLATE NO.
SAN-3

Plot Date: 03/29/2023
 Drawing Name: R:\sanitary\dropinlet\2023 Chaska\2023 Detail Plates\SAN-4.dwg
 User:

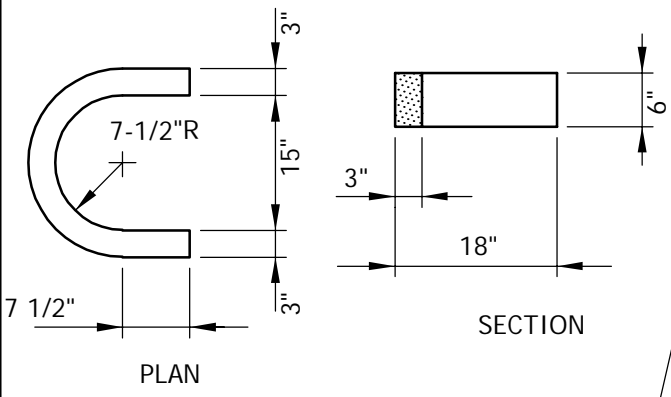

HORSESHOE DETAILS

FRAME	A	B
R1642-2310B	27"	7"
R1755G	27"	7"

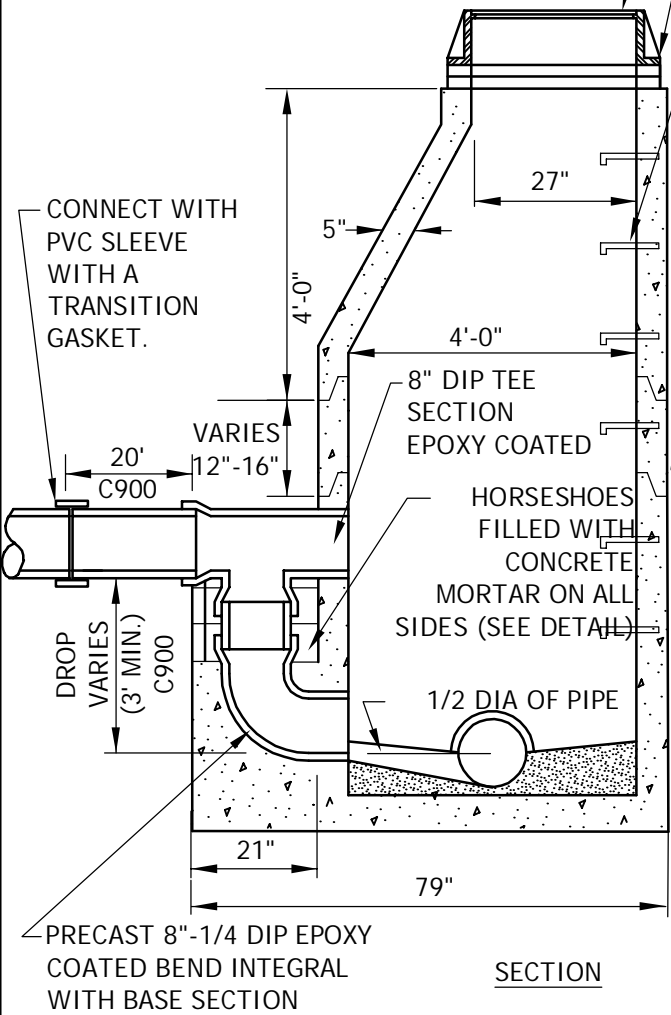

- NEENAH COVER R-1642-5001, LETTERED "SANITARY SEWER", WITH 2 CONCEALED PICK HOLES AND SELF SEALING LID. SEE SPECS. FOR CASTING NUMBERS.
- MINIMUM OF 2 MAXIMUM OF 4 ADJUSTMENT RINGS. FINAL RING MATERIAL AND ADHESIVE TO BE SPECIFIED BY OWNER ON A PROJECT BASIS.
- INSTALL I&I BARRIER BY STRIKE PRODUCTS OR APPROVED EQUAL.
- MAXIMUM 20" ADJUSTMENT ALLOWED INCLUDING RINGS AND CASTING.
- MANHOLE STEPS, COPOLYMER POLYPROPYLENE PLASTIC, WITH 1/2" GRADE 60 STEEL REINFORCEMENT OR EQUAL 16" ON CENTER. (NO STEPS ALLOWED IN UPPER 27" BARREL.)
- MANHOLE STEPS SHALL BE PLACED SO THAT OFFSET VERTICAL PORTION OF CONE IS FACING DOWNSTREAM.
- ALL JOINTS IN MANHOLE TO HAVE SELF LUBRICATING RUBBER GASKETS, RAMNECK, AND GATOR WRAP.
- NOTE: ALL INFILTRATION AREAS SHALL BE REPAIRED UNTIL MANHOLE IS WATER TIGHT.
 - NOTE: OUTER SURFACE OF ALL PRE-CAST SECTIONS SHALL RECEIVE 2 COATS OF BITUMINOUS DAMP PROOFING (SEE ENGINEERING GUIDELINES OR PROJECT SPECIFICATIONS FOR MORE DETAILS).
 - INTERIOR MANHOLE WALL SHALL BE COMPLETELY LINED WITH HDPE OR APPROVED SPRAY ON LINER SYSTEM, SEE SPEC FOR MORE DETAILS.
 - PIPE SHALL BE CUT OUT FLUSH WITH INSIDE FACE OF WALL.
 - NOTE: KOR-N-SEAL MANHOLE TO BE USED FOR PIPE / MANHOLE CONNECTION.
 - ALL DOG HOUSES SHALL BE GROUTED ON INSIDE OF MANHOLE. PRECAST INVERT SHOULD BE 1/2 DIAMETER OF PIPE AND BENCHES SLOPED 2" TOWARD INVERT.



SANITARY SEWER DROP INLET MANHOLE
CHASKA, MINNESOTA

LAST REVISION:
MARCH 2023

PLATE NO.
SAN-4

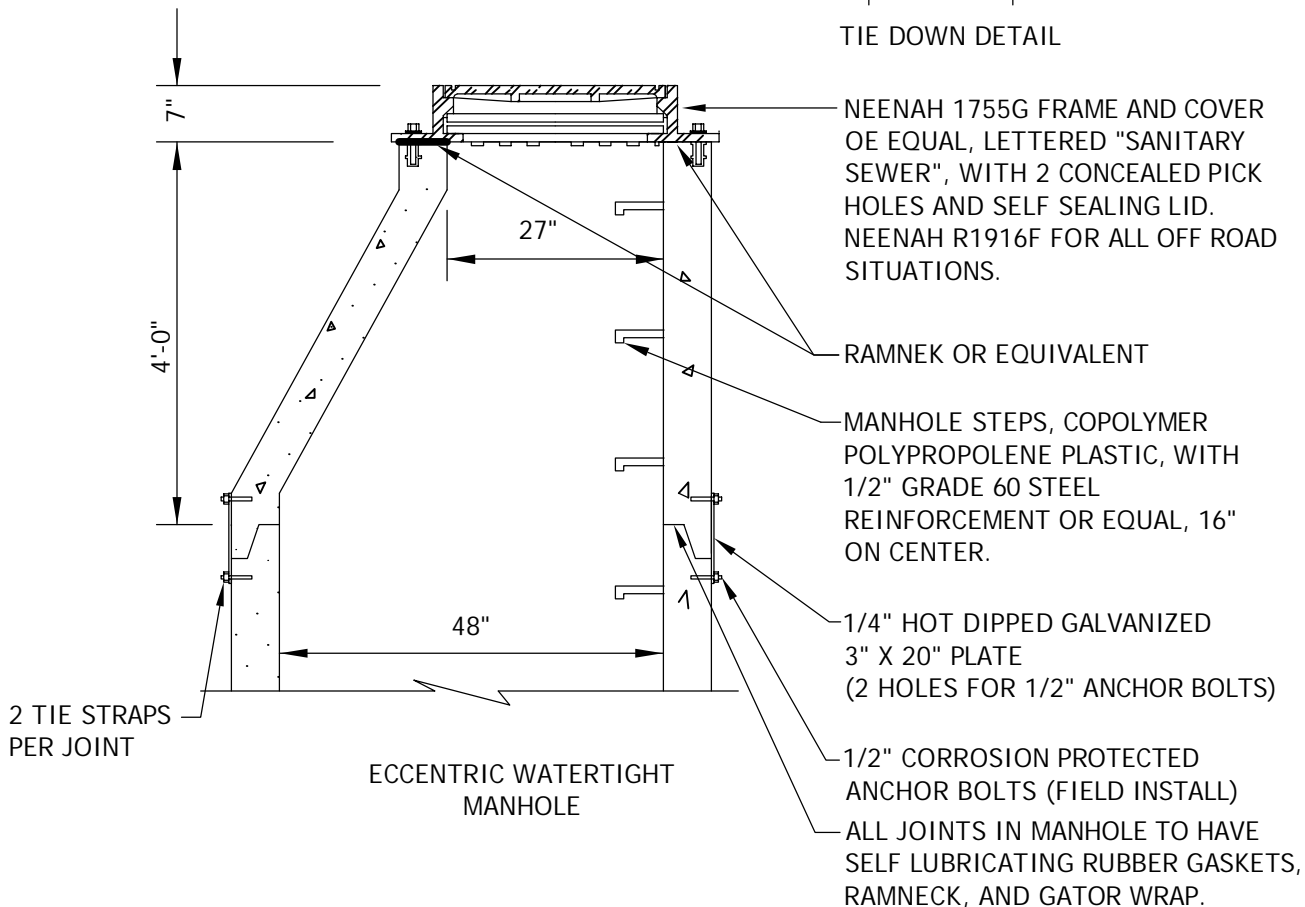
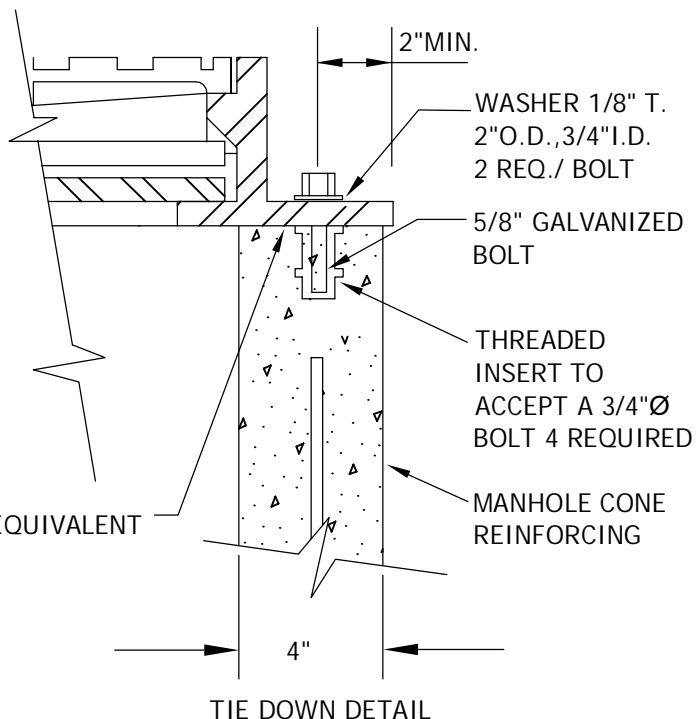
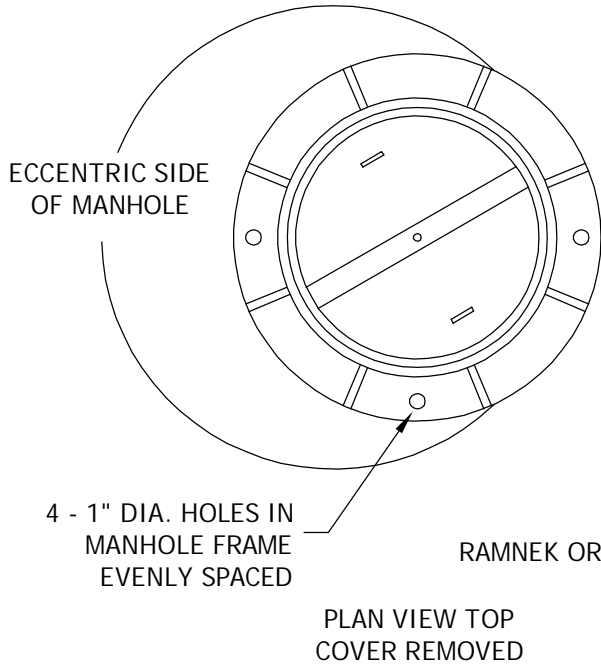

2335 Highway 36 W
 St. Paul, MN 55113
 www.stantec.com

WATERTIGHT CASTING FOR SANITARY SEWER MANHOLE

CHASKA, MINNESOTA

LAST REVISION:
 MARCH 2018

PLATE NO.
 SAN-5

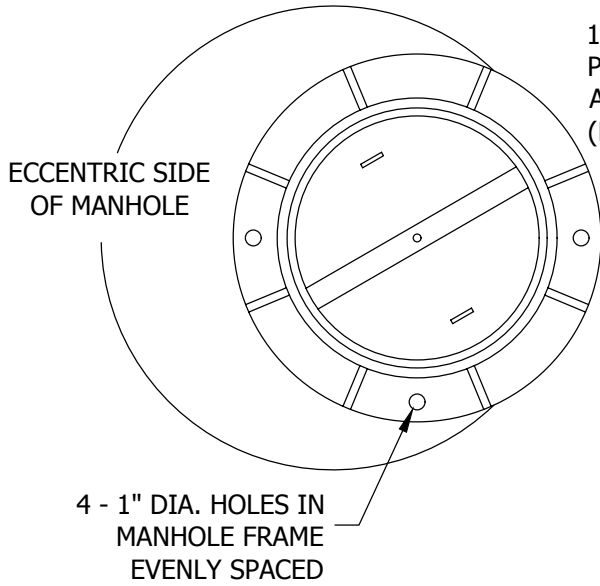

PLAN VIEW
 TOP COVER REMOVED
 WATERTIGHT MANHOLE

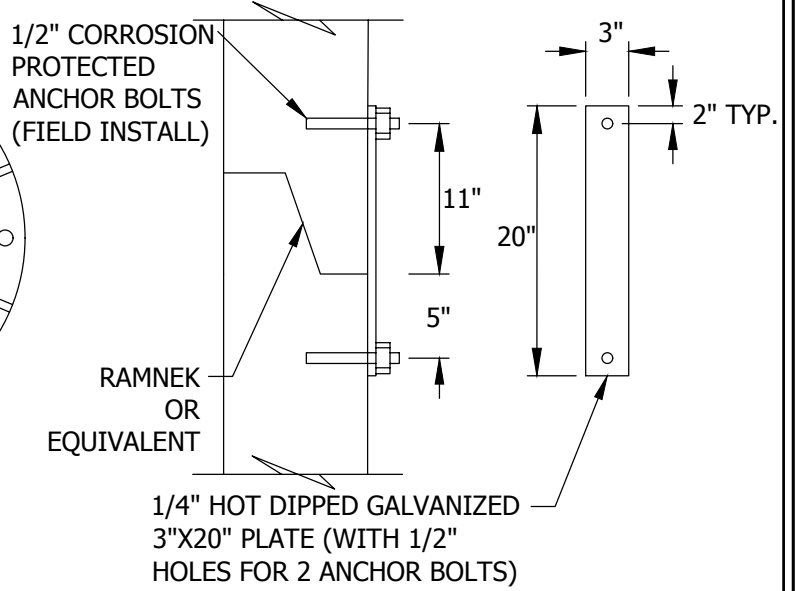

TIE STRAP DETAIL

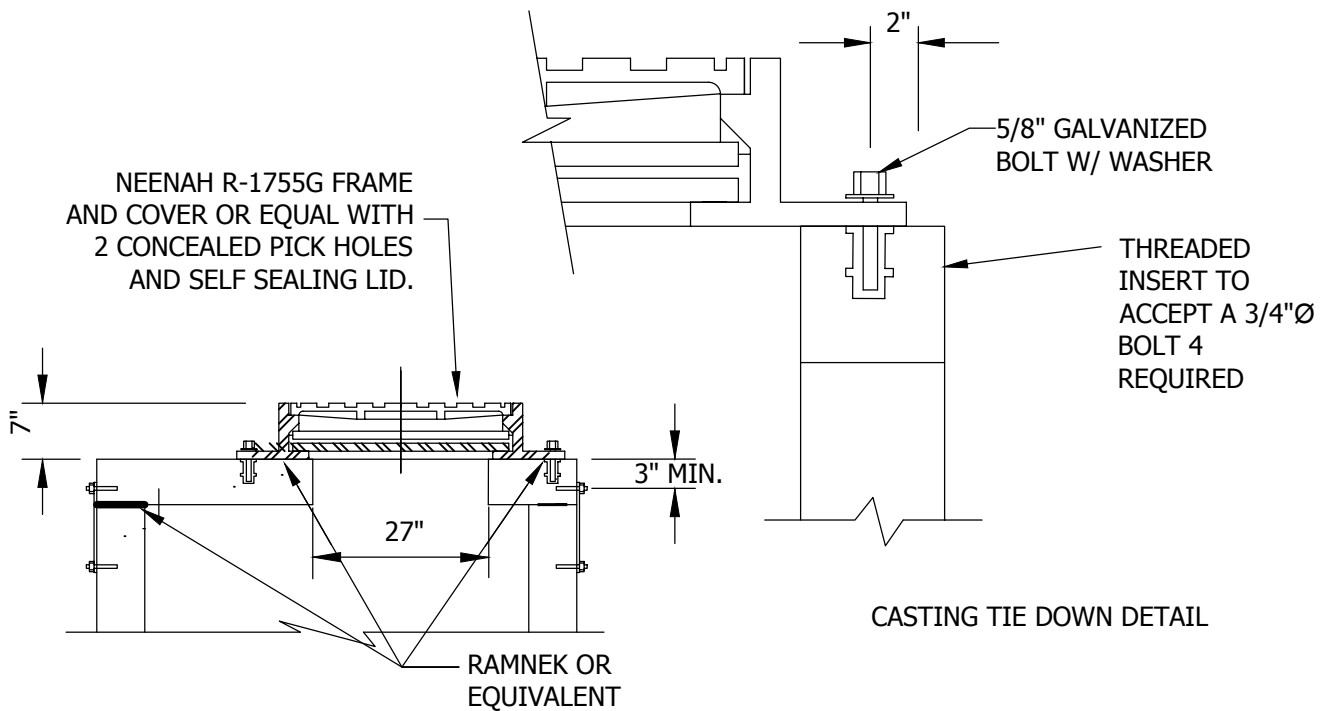

SECTION
 WATERTIGHT MANHOLE

CASTING TIE DOWN DETAIL



2335 Highway 36 W
 St. Paul, MN 55113
 www.stantec.com

**WATERTIGHT CASTING FOR FLAT SLAB
 SANITARY SEWER MANHOLE**

CHASKA, MINNESOTA

LAST REVISION:
 APRIL 2018

PLATE NO.
SAN-6

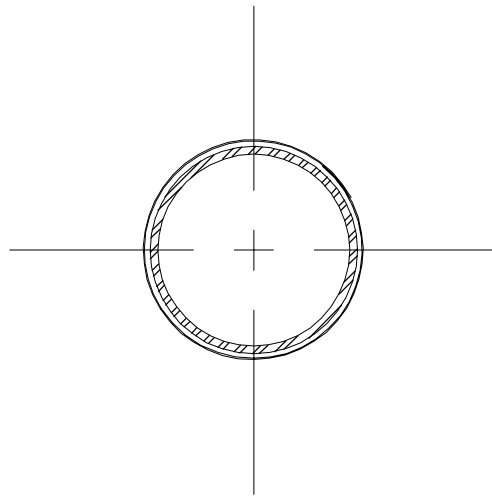
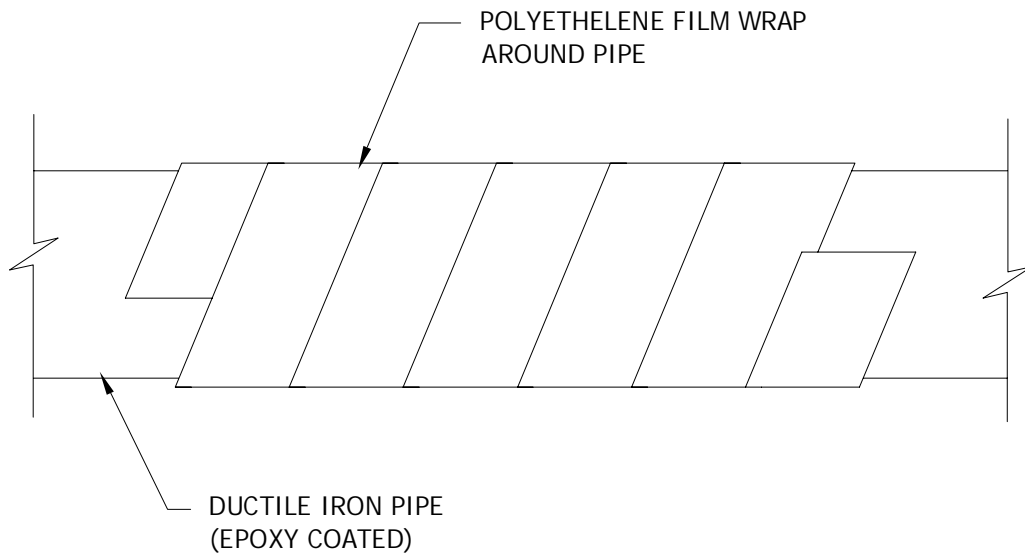

PIPE SECTION



2335 Highway 36 W
St. Paul, MN 55113
www.stantec.com

TYPICAL FORCEMAIN
INSTALLATION

CHASKA, MINNESOTA

LAST REVISION:
APRIL 2004

PLATE NO.
SAN-7

Plot Date: 03/29/2023
 Drawing Name: R:\sanitary\16142\16142.dwg
 User: Xie

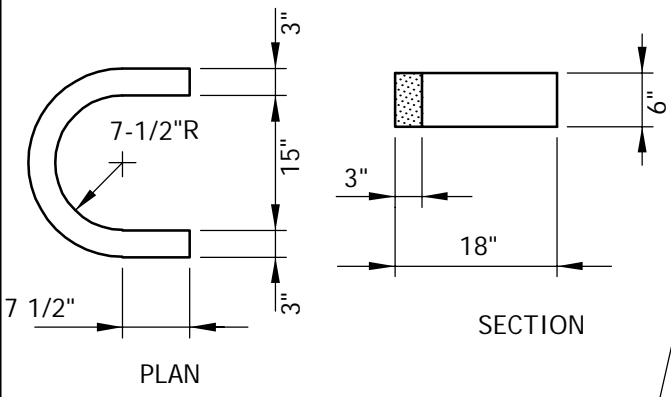

HORSESHOE DETAILS

FRAME	A	B
R1642-2310B	27"	7"
R1755G	27"	7"

NEENAH COVER R-1642-5001, LETTERED "SANITARY SEWER", WITH 2 CONCEALED PICK HOLES AND SELF SEALING LID. SEE SPECS. FOR CASTING NUMBERS.

MINIMUM OF 2 MAXIMUM OF 4 ADJUSTMENT RINGS. FINAL RING MATERIAL AND ADHESIVE TO BE SPECIFIED BY OWNER ON A PROJECT BASIS.

INSTALL I&I BARRIER BY STRIKE PRODUCTS OR APPROVED EQUAL.

- MAXIMUM 20" ADJUSTMENT ALLOWED INCLUDING RINGS AND CASTING.

ALL JOINTS IN MANHOLE TO HAVE SELF LUBRICATING RUBBER GASKETS, RAMNECK, AND GATOR WRAP.

- NOTE: ALL INFILTRATION AREAS SHALL BE REPAIRED UNTIL MANHOLE IS WATER TIGHT.

- NOTE: OUTER SURFACE OF ALL PRE-CAST SECTIONS SHALL RECEIVE 2 COATS OF BITUMINOUS DAMP PROOFING (SEE ENGINEERING GUIDELINES OR PROJECT SPECIFICATIONS FOR MORE DETAILS).

- INTERIOR MANHOLE WALL SHALL BE COMPLETELY LINED WITH HDPE OR APPROVED SPRAY ON LINER SYSTEM, SEE SPEC FOR MORE DETAILS.

- PIPE SHALL BE CUT OUT FLUSH WITH INSIDE FACE OF WALL.

- NOTE: KOR-N-SEAL MANHOLE TO BE USED FOR PIPE / MANHOLE CONNECTION.

- ALL DOG HOUSES SHALL BE GROUTED ON INSIDE OF MANHOLE. PRECAST INVERT SHOULD BE 1/2 DIAMETER OF PIPE AND BENCHES SLOPED 2" TOWARD INVERT.

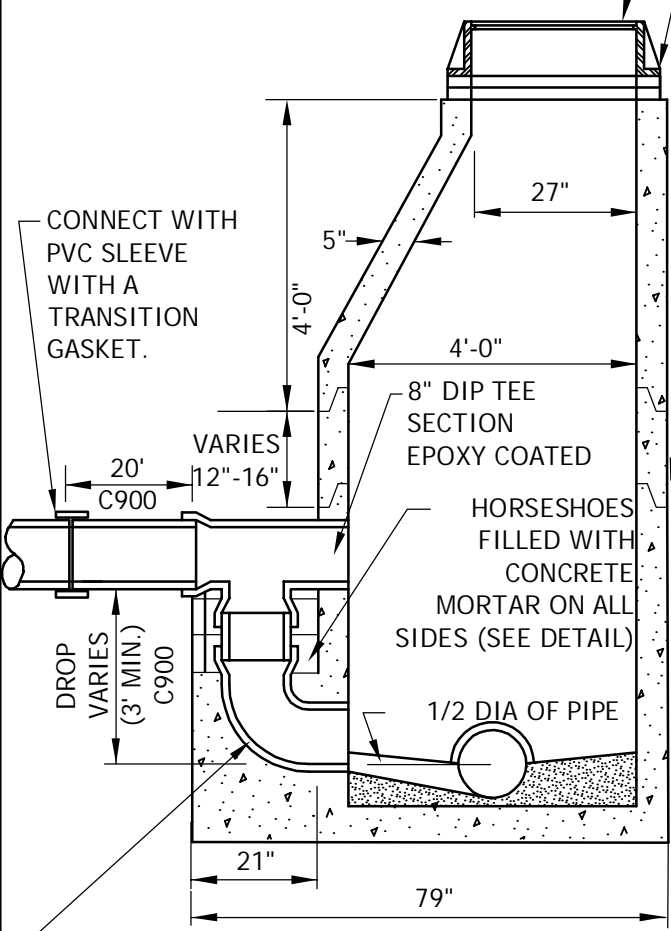

SECTION

PRECAST 8"-1/4 DIP EPOXY COATED BEND INTEGRAL WITH BASE SECTION

CONNECT WITH PVC SLEEVE WITH A TRANSITION GASKET.

20' C900

VARIES 12"-16"

DROP VARIES (3' MIN.) C900

8" DIP TEE SECTION EPOXY COATED

HORSESHOES FILLED WITH CONCRETE MORTAR ON ALL SIDES (SEE DETAIL)

1/2 DIA OF PIPE



**SANITARY SEWER DROP INLET MANHOLE
PIPES LARGER THAN 12"**

CHASKA, MINNESOTA

LAST REVISION:
MARCH 2023

PLATE NO.
SAN-8



DROP LID
 TYLER
 MUELLER
 BIBBY-STE-CROIX

NO. 6860
 NO. H-10361
 NO. B-5160

NOTES: CORE BLUE BOLTS REQUIRED FOR ALL MECHANICAL FITTINGS. ANTI-CORROSIVE COATING REQUIRED ON ALL BOLTS AND TIE ROD ASSEMBLIES.

- PROVIDE POLYWRAP AROUND ALL WATERMAIN
- 7.5' MINIMUM COVER REQUIRED OVER TOP OF WATER MAIN.
- RESTRAIN TEE AND VALVE WITH EPOXY COATED MEGALUG (OR EQUAL) THRUST RESTRAINTS.

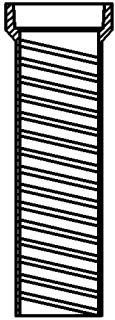

TOP
 TYLER
 MUELLER
 BIBBY-STE-CROIX

NO. 6860 26"
 NO. H-10361 26"
 NO. VB502 27"

GRADE

- ADJUST TOP TO 1/2" BELOW GRADE. BOX TO BE SET TO PROVIDE 12" OF ADJUSTMENT.

- TYLER NO. 6860 MUELLER NO. H-10357 BIBBY-STE-CROIX B-5001 GATE VALVE BOX, SCREW TYPE, 3 PIECE, 5 1/4" SHAFT, SIZE G BOX, 7'-6" EXTENDED, #6 ROUND BASE

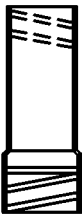

EXTENSION
 TYLER

NO. 58 14"
 NO. 59 18"
 NO. 60 24"

- PROVIDE VALVE STEM RISERS TO WITHIN 1 FOOT OF THE SURFACE.

MUELLER

NO. 58 14"
 NO. 59 20"

BIBBY-STE-CROIX
 VB520 VB521
 VB522 VB523

NO. 57 9"
 NO. 58 14"
 NO. 59 20"
 NO. 60 26"

GATE VALVE ADAPTER: 1/4" STEEL WITH PROTECTIVE COATING, 1/2" RUBBER GASKET INSTALLED BETWEEN THE GATE VALVE AND GATE VALVE ADAPTER.

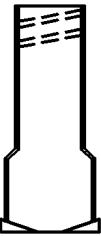

BOTTOM
 TYLER
 MUELLER
 BIBBY-STE-CROIX

NO. 6860 65"
 NO. H-10361 65"
 NO. VB516 60"

- RESILIENT WEDGE VALVE CONFORMING TO AWWA C509-DI OR C515 STANDARDS WITH STAINLESS STEEL BOLTS AND BRONZE TOP NUT

3'

6 oz. ZINC ANODE CAP. SEE ENGINEERING GUIDELINES

BASE

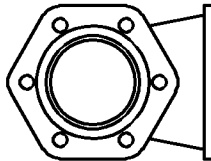

MEGALUGS

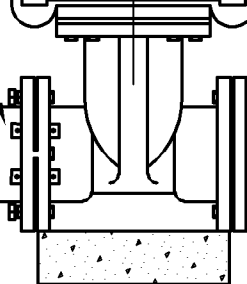

MEGALUGS

8" CONC. BLOCK



733 Marquette Ave Suite 1000
 Minneapolis, MN 55402
 www.stantec.com

GATE VALVE AND BOX INSTALLATION

CHASKA, MINNESOTA

LAST REVISION:
 MARCH 2019

PLATE NO.
 WAT-1

Plot Date: 09/01/2023
 Working Name: R:\chaska\plans\2023\chaska\2023 Detail Plates\WAT-2.DWG
 Xref:

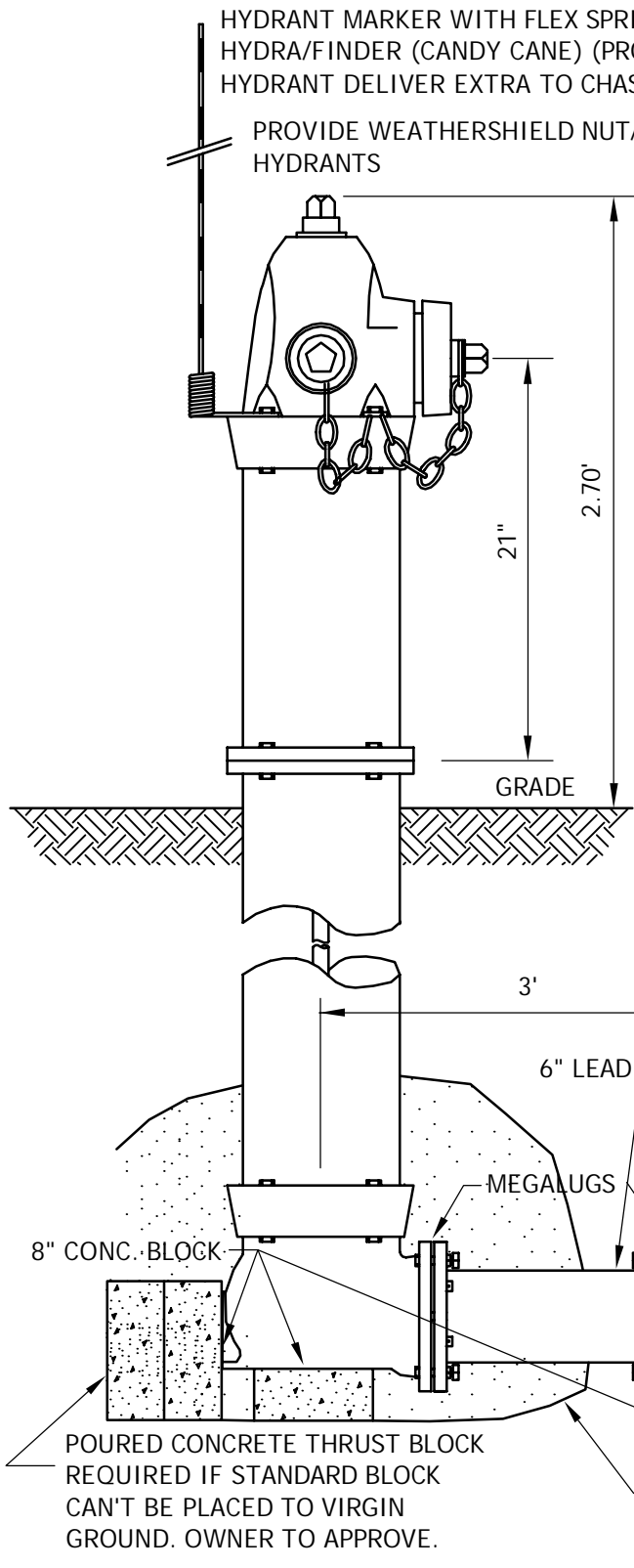

ALL HYDRANT LEAD AND PIPE JOINTS SHALL BE RESTRAINED WITH TIE RODS AND EPOXY COATED MEGALUGS.

HYDRANT SHALL BE WATEROUS PACER WB-67-250 WITH 16" TRAFFIC BREAK OFF SECTION, AND EPOXY COATED BOOT.

HYDRANT SHALL BE FOR 8.0' BURY. WATERMAIN SHALL HAVE 7'-6" OF COVER.

PROVIDE A VENTED CAP ON ONE 2 1/2" NOZZLE.

CORE BLUE BOLTS REQUIRED FOR ALL MECHANICAL FITTINGS. ANTI-CORROSIVE COATING REQUIRED ON ALL BOLTS AND TIE ROD ASSEMBLIES.

FOR VALVE BOX INSTALLATION SEE DETAIL PLATE NO. WAT-1.

RESTRAIN HYDRANT, VALVE, AND TEE WITH MEGALUG THRUST RESTRAINT (OR EQUAL)

PROVIDE POLYWRAP AROUND ALL WATERMAIN (GENERAL REQUIREMENTS) AND UP THE HYDRANT BARREL TO THE BREAK OFF FLANGE.

RESILIENT WEDGE VALVE CONFORMING TO AWWA C-509-D1 STANDARDS WITH STAINLESS STEEL BOLTS AND BRONZE TOP NUT

8" CONC. BLOCK

POURED CONCRETE THRUST BLOCK REQUIRED IF STANDARD BLOCK CAN'T BE PLACED TO VIRGIN GROUND. OWNER TO APPROVE.

1 CU. YD. OF 1 1/2" IGNEOUS ROCK ONLY. MINIMUM OF 1' ABOVE WEEP HOLES. COVER WITH 2 LAYERS OF POLYETHYLENE.

6 oz. ZINC ANODE CAP. SEE ENGINEERING GUIDELINES



733 Marquette Ave Suite 1000
 Minneapolis, MN 55402
 www.stantec.com

WATEROUS PACER HYDRANT AND VALVE INSTALLATION

CHASKA, MINNESOTA

LAST REVISION:
 AUGUST 2023

PLATE NO.
 WAT-2

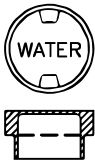

DROP LID
 TYLER
 MUELLER
 BIBBY-STE-CROIX

NOTES: CORE BLUE BOLTS REQUIRED FOR ALL MECHANICAL FITTINGS. ANTI-CORROSIVE COATING REQUIRED ON ALL BOLTS AND TIE ROD ASSEMBLIES.

 PROVIDE POLYWRAP AROUND ALL WATERMAIN

 7.5' MINIMUM COVER REQUIRED OVER TOP OF WATER MAIN.

 RESTRAIN TEE AND VALVE WITH MEGALUG (OR EQUAL) THRUST RESTRAINTS.

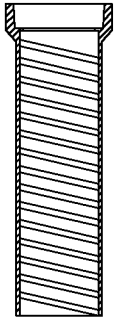

TOP
 TYLER
 MUELLER
 BIBBY-STE-CROIX

	NO.	GRADE
TYLER	NO. 6850	26"
MUELLER	NO. H-10361	26"
BIBBY-STE-CROIX	NO. VB502	27"

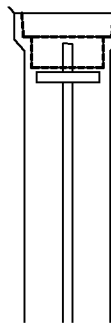

ADJUST TOP TO 1/2" BELOW GRADE. BOX TO BE SET TO PROVIDE 12" OF ADJUSTMENT.

TYLER NO. 6850 MUELLER NO. H-10357 BIBBY-STE-CROIX B-5001 GATE VALVE BOX, SCREW TYPE, 3 PIECE, 5 1/4" SHAFT, SIZE G BOX, 7'-6" EXTENDED.

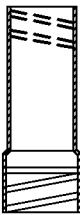

EXTENSION
 TYLER

TYLER	NO. 58	14"
	NO. 59	18"
	NO. 60	24"



MUELLER

MUELLER	NO. 58	14"
	NO. 59	20"

BIBBY-STE-CROIX

BIBBY-STE-CROIX	NO. 57	9"
	NO. 58	14"
	NO. 59	20"
	NO. 60	26"

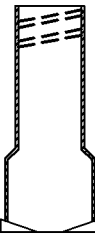

BOTTOM
 TYLER
 MUELLER
 BIBBY-STE-CROIX

TYLER	NO. 6850	65"
MUELLER	NO. H-10361	65"
BIBBY-STE-CROIX	NO. VB516	60"

BUTTERFLY VALVE (14" OR LARGER) DRESSER 450, PRATT GROUNDHOG, KENNEDY, OR EQUAL.

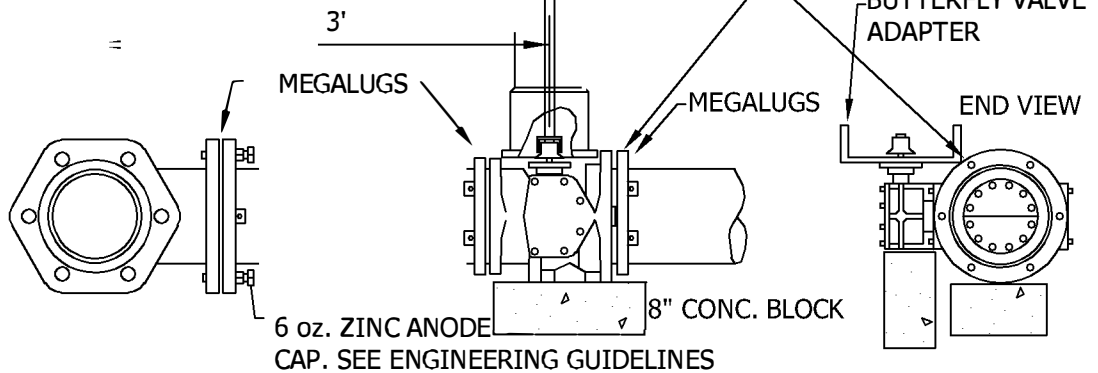

6 oz. ZINC ANODE
 CAP. SEE ENGINEERING GUIDELINES



733 Marquette Ave Suite 1000
 Minneapolis, MN 55402
 www.stantec.com

BUTTERFLY VALVE AND BOX INSTALLATION

CHASKA, MINNESOTA

LAST REVISION:
 MARCH 2019

PLATE NO.
 WAT-3

NOTES:

1. SHAPE OF BACK OF BUTTRESS MAY VARY AS LONG AS Poured AGAINST FIRM UNDISTURBED EARTH.
2. DIMENSION C1,C2,C3 SHOULD BE LARGE ENOUGH TO MAKE ANGLE θ EQUAL TO OR LARGER THAN 45° .
3. DIMENSION A1,A2,A3 SHOULD BE AS LARGE AS POSSIBLE WITHOUT INTERFERING WITH MJ BOLTS.
4. PROVIDE POLYETHYLENE WRAP AROUND ALL WATERMAIN.
5. ALL BENDS AND FITTINGS SHALL BE RESTRAINED WITH BOTH EPOXY COATED MEGA-LUGS AND THRUST BLOCKING.

BUTTRESS DIMENSIONS						
PIPE SIZE	22 1/2° BEND		45° BEND		90° BEND	
	B1	D1	B2	D2	B3	D3
6"	1'-5"	1'-5"	1'-5"	1'-5"	2'-1"	1'-6"
8"	1'-5"	1'-5"	2'-1"	1'-6"	2'-8"	2'-0"
12"	1'-10"	1'-10"	3'-4"	2'-0"	4'-9"	2'-6"
16"	3'-0"	2'-0"	3'-10"	3'-0"	6'-2"	3'-6"
20"	3'-6"	2'-8"	5'-6"	3'-4"	8'-4"	4'-0"
24"	4'-4"	3'-0"	6'-10"	3'-10"	9'-8"	5'-0"
30"	-	-	9'-3"	6'-0"	17'-0"	6'-0"

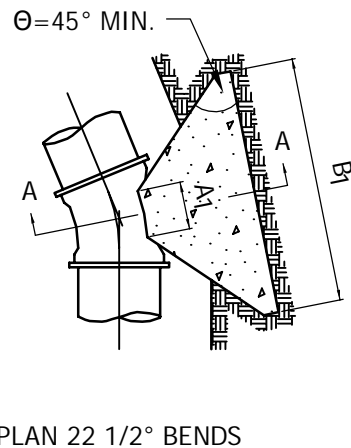
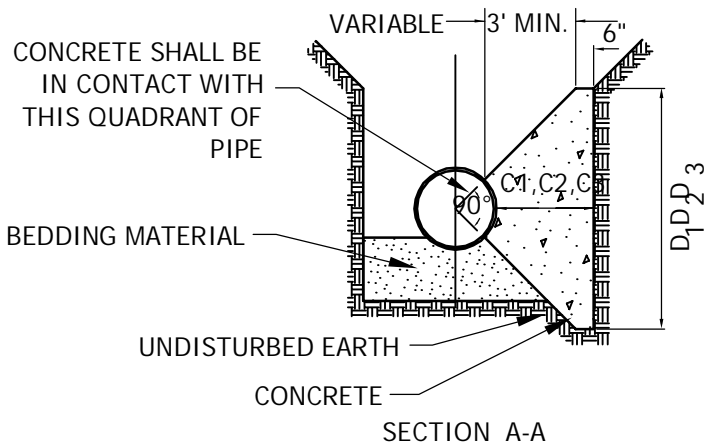
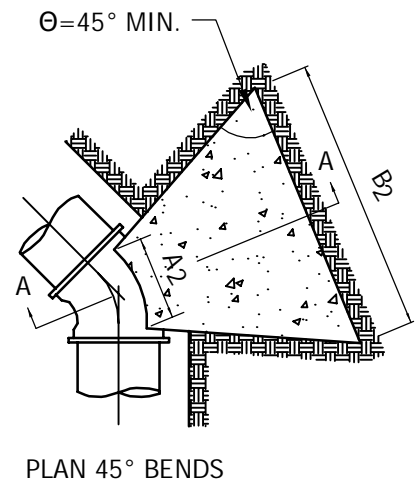
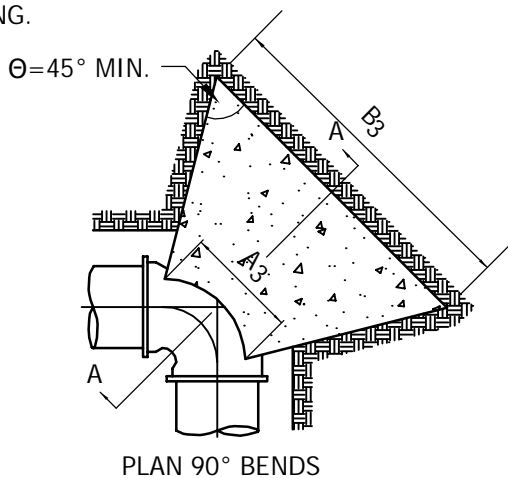

2335 Highway 36 W
 St. Paul, MN 55113
 www.stantec.com

CONCRETE THRUST BLOCKING

CHASKA, MINNESOTA

LAST REVISION:
 APRIL 2005

PLATE NO.
WAT-4

NOTES: CORE BLUE BOLTS REQUIRED FOR ALL MECHANICAL FITTINGS. ANTI-CORROSIVE COATING REQUIRED ON ALL BOLTS AND TIE ROD ASSEMBLIES.

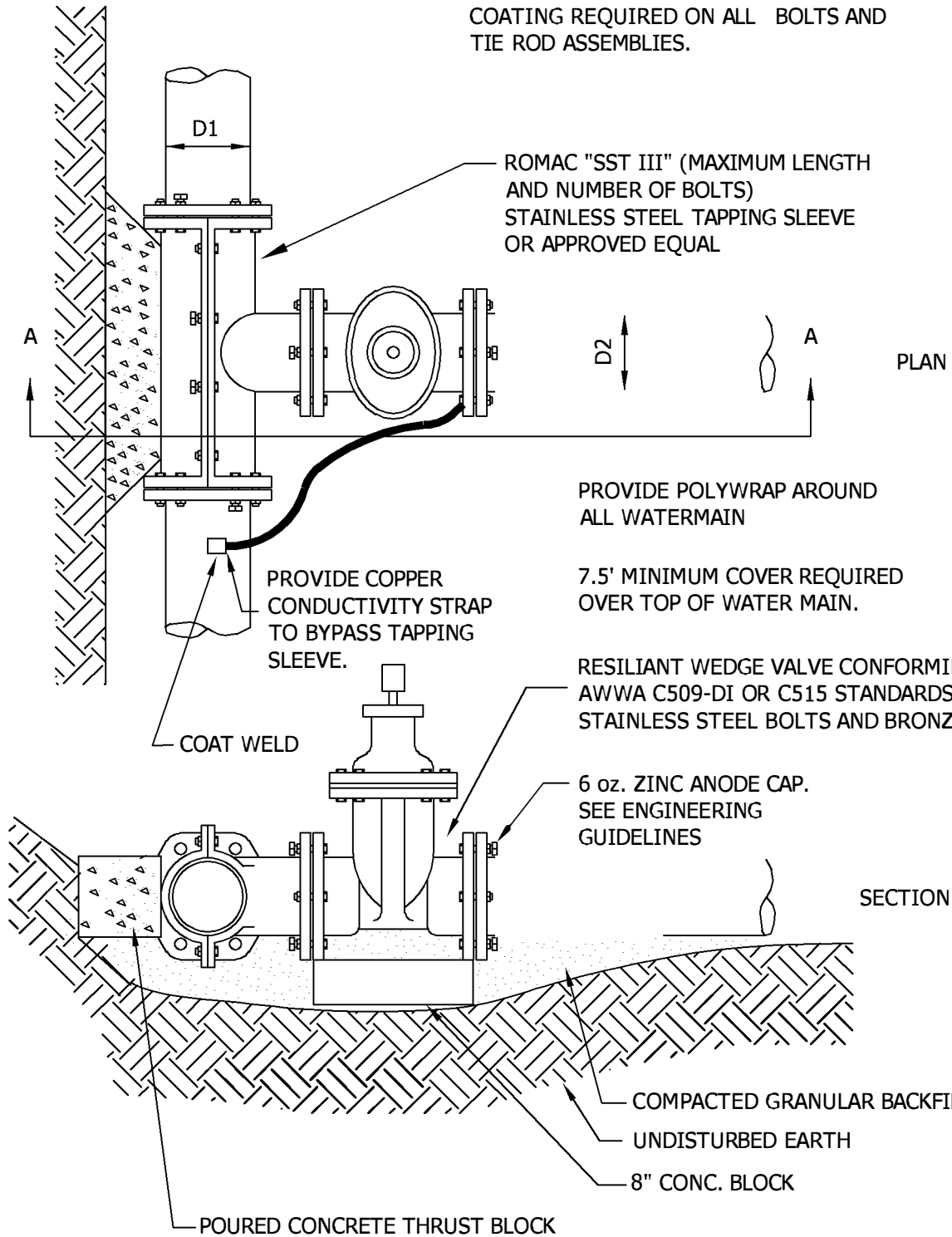

Date: 03/27/2019
 Drawing Name: K:\as\chaska\chaska\1502019\DWG\PLATE\WAT-5.DWG
 Xref:



733 Marquette Ave Suite 1000
 Minneapolis, MN 55402
 www.stantec.com

WATER MAIN WET TAP

CHASKA, MINNESOTA

LAST REVISION:
 MARCH 2019

PLATE NO.
 WAT-5

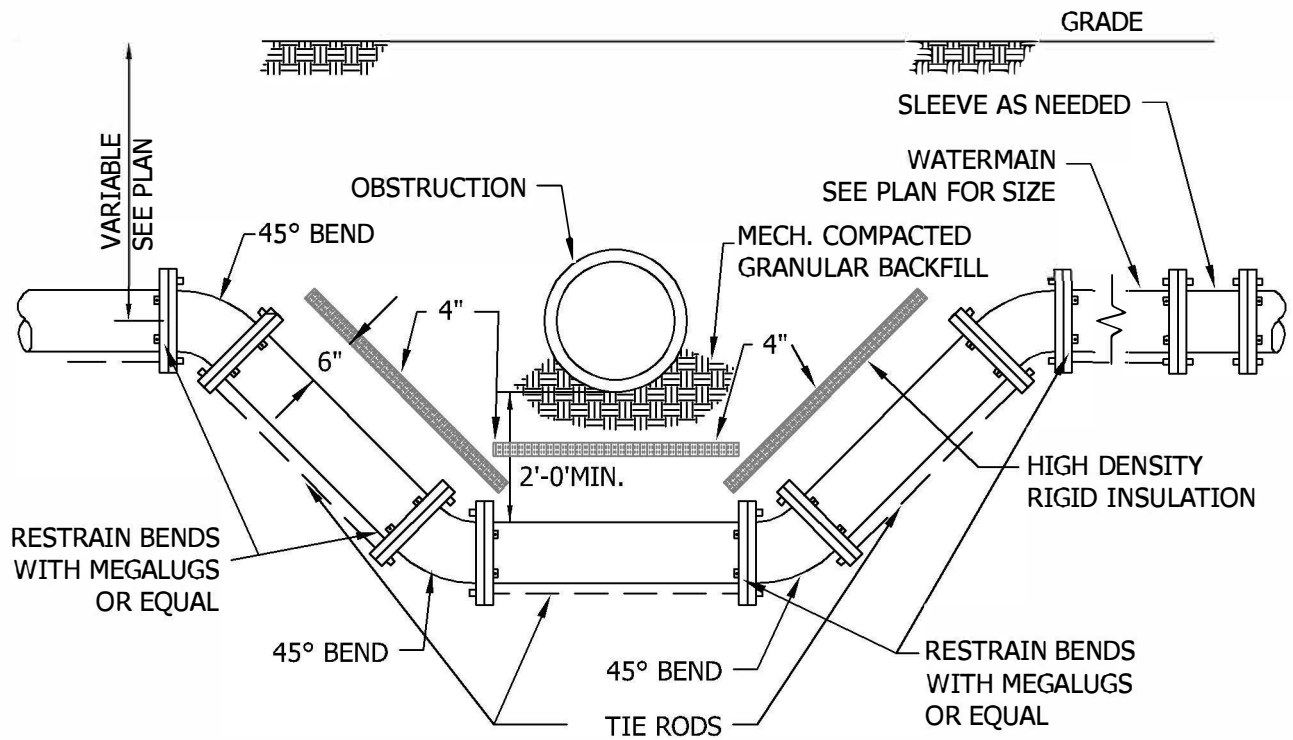

1. USE EPOXY COATED MEGALUG THRUST RESTRAINTS AND COATED TIE RODS ON ALL JOINTS AND FITTINGS. CORE BLUE BOLTS REQUIRED ON ALL MECHANICAL JOINTS.
2. RESTRAIN A MINIMUM OF TWO PIPE JOINTS (40 LF) LEFT AND RIGHT OF THE LOWERING.
3. SEE PLATE NO. GEN-11 TO DETERMINE THE WIDTH OF THE INSULATING BOARD REQUIRED
4. SEE PLATE NO. WAT-4 TO DETERMINE THE REQUIRED CONCRETE THRUST BLOCKING.
5. ANTI CORROSIVE COATING REQUIRED ON ALL BOLT AND RESTRAINT ASSEMBLIES AND WELDS.
6. SACRIFICIAL ZINC ANODE CAPS ON EACH SIDE OF WATER FITTINGS. SEE ENGINEERING GUIDELINES.
7. INSTALL POLYETHELENE FILM WRAP AROUND ALL PIPE INCLUDED IN THE LOWERING.



733 Marquette Ave Suite 1000
 Minneapolis, MN 55402
 www.stantec.com

WATER MAIN LOWERING WITH INSULATION DETAIL

CHASKA, MINNESOTA

LAST REVISION:
 MARCH 2019

PLATE NO.
 WAT-6

Plot Date: 05/28/2014
Drawing name: R:\cadd\dwg\plates\05282014\Detail Plates\WAT-7.DWG
User:

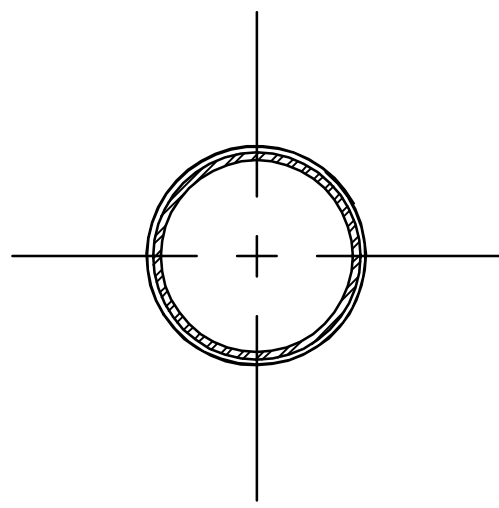
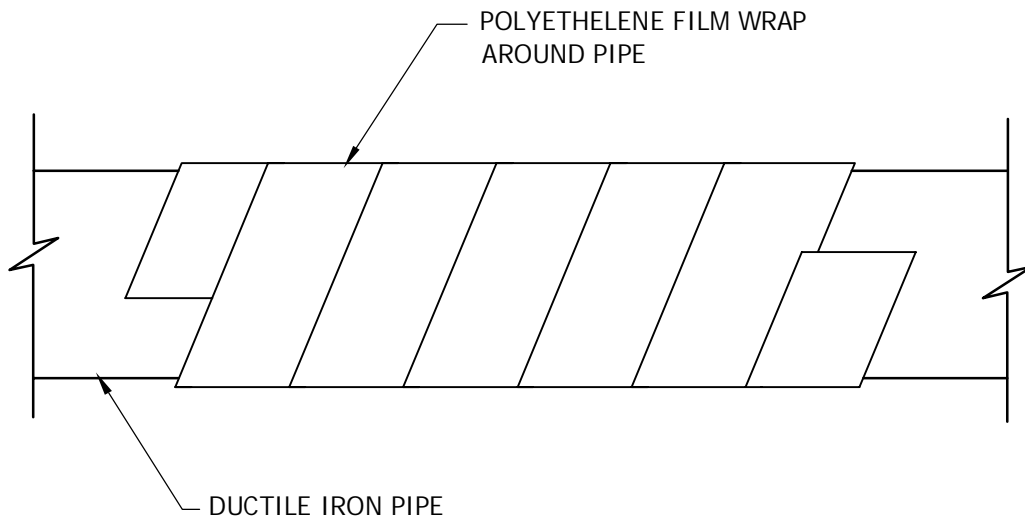

PIPE SECTION



2335 Highway 36 W
St. Paul, MN 55113
www.stantec.com

TYPICAL
WATER MAIN INSTALLATION

CHASKA, MINNESOTA

LAST REVISION:
MARCH 2008

PLATE NO.
WAT-7

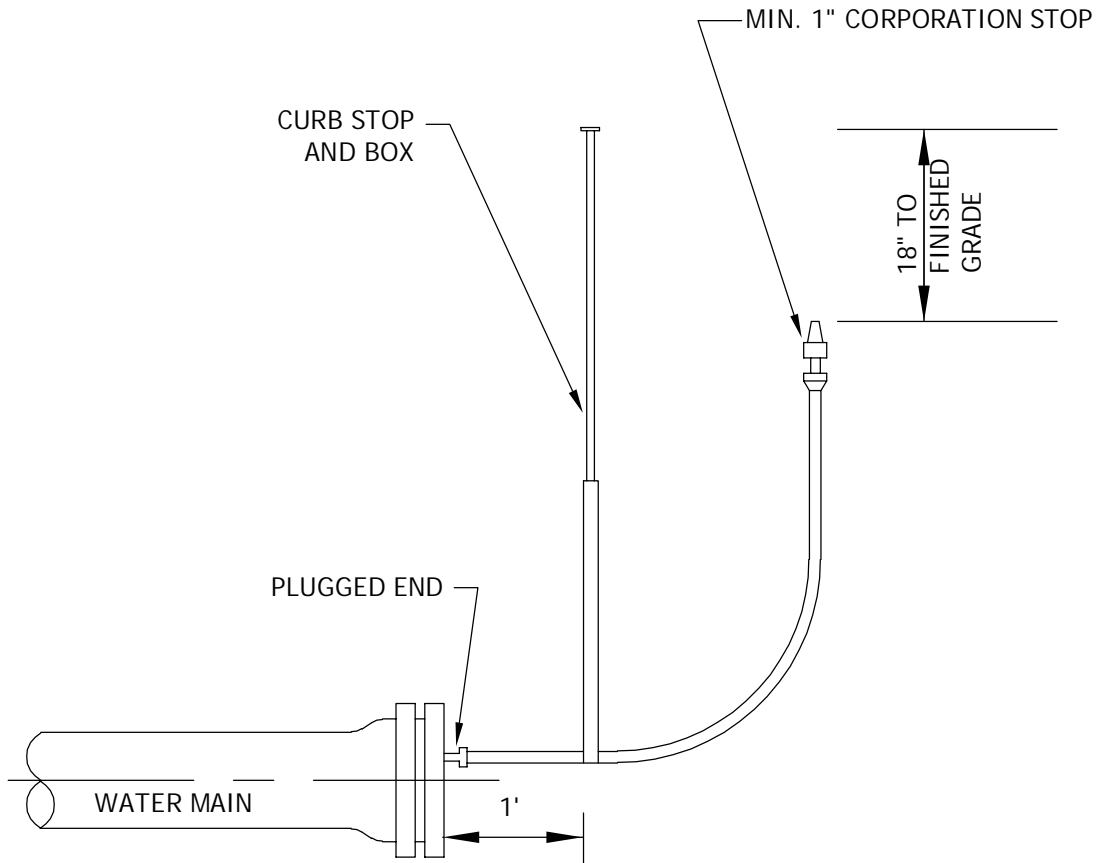

AFTER MEETING TEST REQUIREMENTS
AND FLUSHING THE AIR BLEED LINE
SHALL BE DISCONNECTED AT THE
PLUG WITH NO ADDITIONAL
COMPENSATION.



2335 Highway 36 W
St. Paul, MN 55113
www.stantec.com

TYPICAL AIR BLEED INSTALLATION

CHASKA, MINNESOTA

LAST REVISION:
MARCH 2023

PLATE NO.
WAT-8

Plot Date: 03/27/2016
Drawing Name: R:\scandrew\plans\9212016\DWG\Plumbing\WAT-9.dwg
Xref(s):

TOP SECTION CONSTRUCTED OF
CAST IRON
BASE SECTION CONSTRUCTED OF
ABS PLASTIC, FLARED AT THE
BOTTOM.

TRACER WIRE BOX BY VALVCO,
OR APPROVED EQUAL

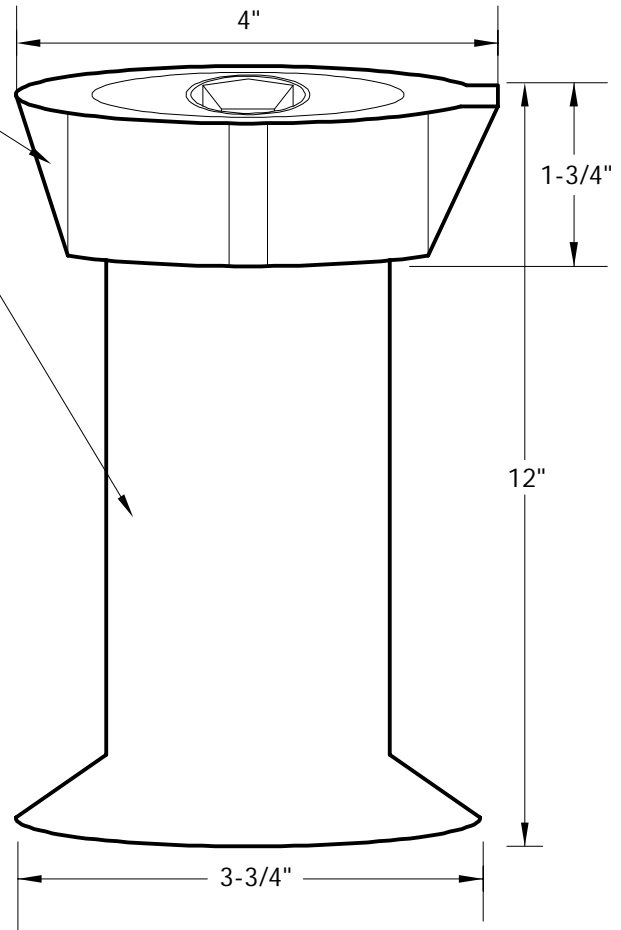
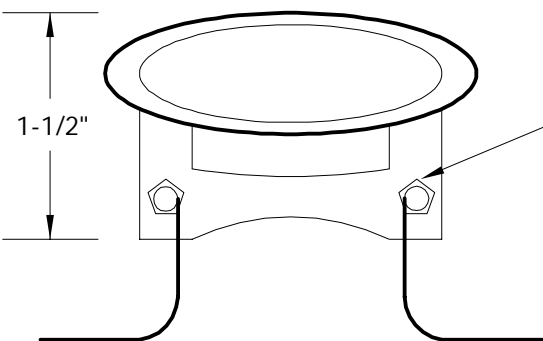
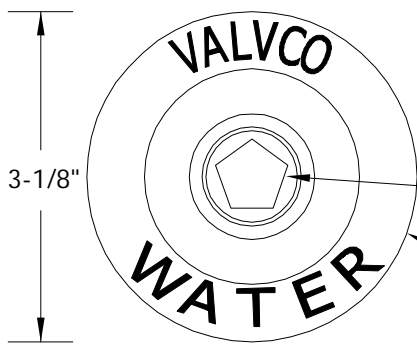
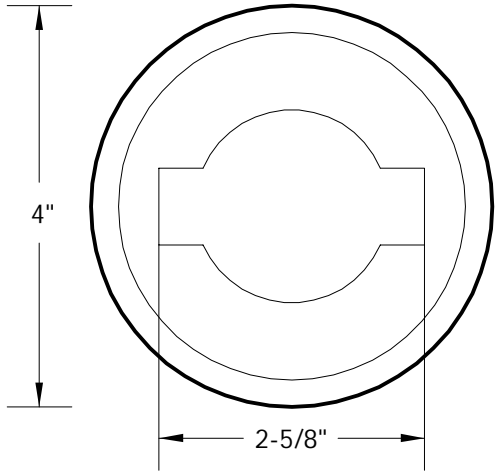

LID SHALL BE ABLE TO LOCK AND
UNLOCK WITH A STANDARD
PENTAGON HEAD 1/2" KEY
WRENCH.

ACCESS BOX LID SHALL BE MADE
OF CAST IRON AND INSTALLED TO
GRADE.

#12 SOLID INSULATED TRACER WIRE
SHALL BE STRIPPED AND ATTACHED
TO STAINLESS STEEL SCREWS
MOUNTED TO UNDERSIDE OF LID.

SUFFICIENT SLACK SHALL BE
LEFT IN WIRE SO COVER MAY
BE LIFTED WITH WIRE STILL
INTACT.



DIP TO C900 WATERMAIN
TRANSITION FOR TRACER WIRE

CHASKA, MINNESOTA

LAST REVISION:
MAY 2016

PLATE NO.
WAT-9

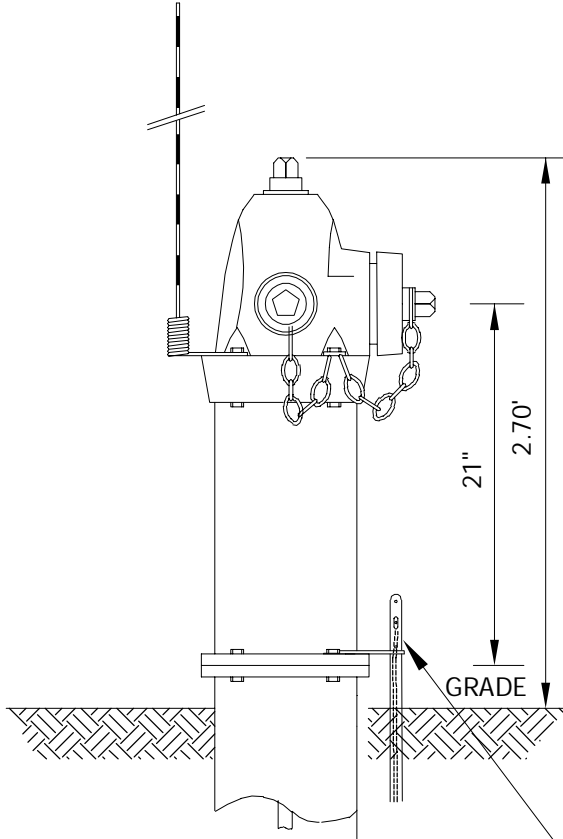

COPPERHEAD COBRA 2
TERMINAL ACCESS POINT
WITH FLANGE (BLUE)
WITH 2' LONG 1" ϕ CONDUIT



2335 Highway 36 W
St. Paul, MN 55113
www.stantec.com

TRACER WIRE FOR PVC WATER MAIN

CHASKA, MN

LAST REVISION:
JANUARY 2022

PLATE NO.
WAT-10

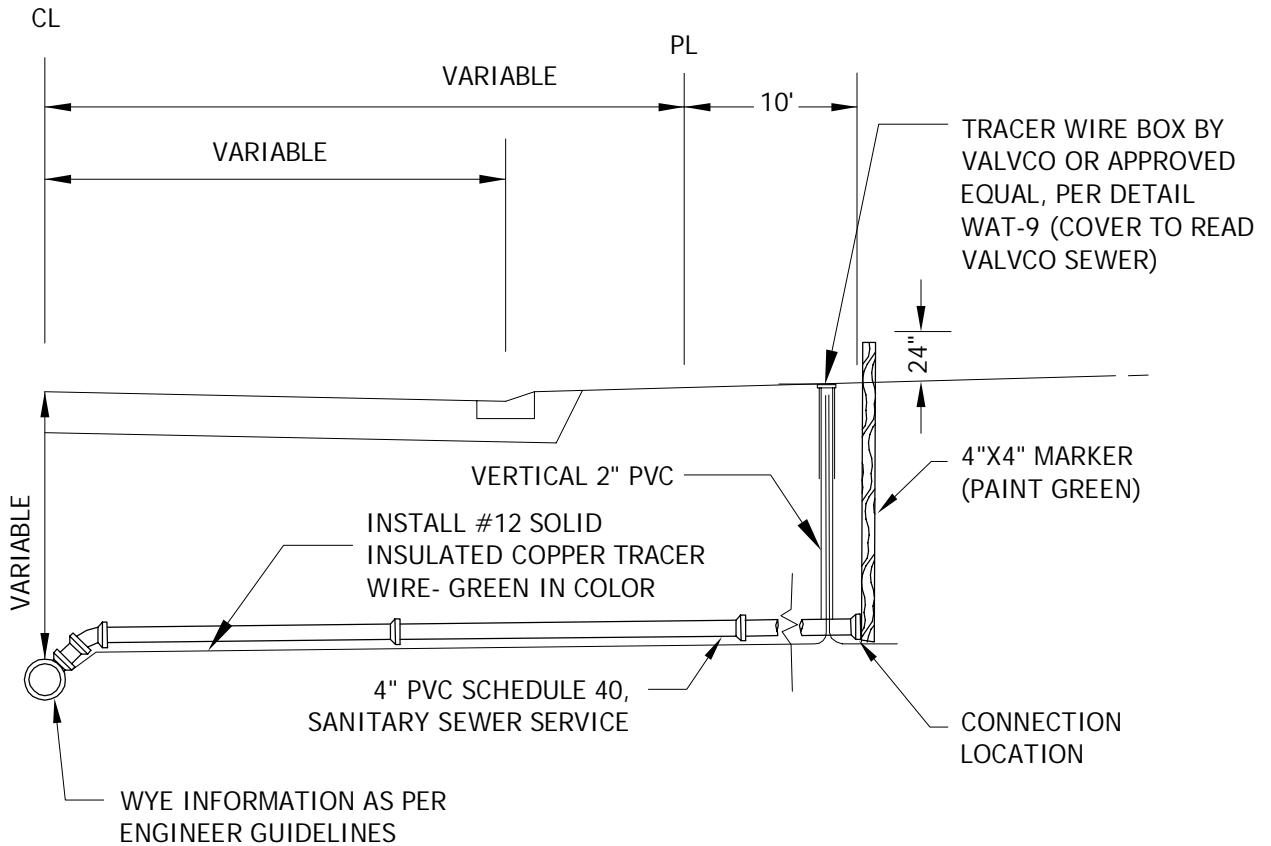

NOTES:

1. SEWER SERVICES, 4" SCHEDULE 40 PVC SEWER PIPE
2. SLOPE - 1/4" PER FOOT MINIMUM.
3. PIPE JOINTS SHALL BE NON GASKETED, SOLVENT WELD TYPE.
4. ALL PIPE SHALL BE BEDDED IN GRANULAR BORROW 3149.2B1 EXCEPT THE LAST TEN FEET WHERE COARSE FILTER AGGREGATE (3149.2H) AGGREGATE WILL BE REQUIRED.
5. BENDS OF 45° OR LESS SHALL BE USED WITHIN THE LAST 5' OF THE SERVICE IF THE DEPTH OF THE SERVICE WOULD EXCEED 10'.
6. NO SERVICE RISERS LESS THAN 3 FEET SHALL BE PERMITTED.
7. A SEPARATE TRACER WIRE WILL EXTEND FROM THE FINISH GRADE AT TRACER WIRE BOX AND FOLLOW SEWER SERVICE TO STRUCTURE FOUNDATION. TRACER WIRE FROM BOX TO FOUNDATION BY OTHERS.
8. FOR DEPTHS GREATER THAN 22', SERVICE PIPE SHALL BE C900 FROM MAIN TO CONNECTION, WITH TRANSITION FITTING FROM C900 TO SCH 40 INSTALLED AT CONNECTION LOCATION.



2335 Highway 36 W
 St. Paul, MN 55113
 www.stantec.com

SEWER SERVICE CONNECTION

CHASKA, MINNESOTA

LAST REVISION:
 APRIL 2016

PLATE NO.
 SER-1

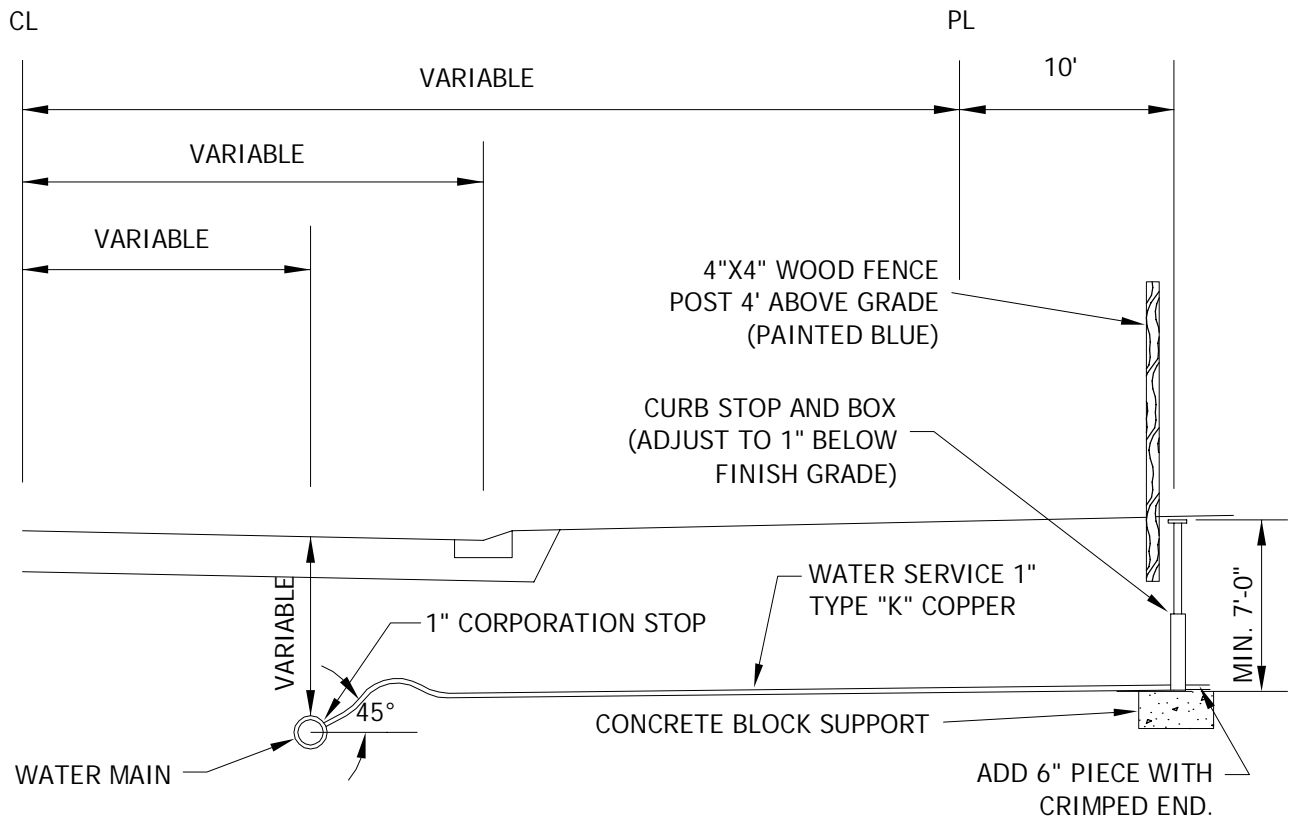

PVC WATER MAIN
 STAINLESS STEEL
 SERVICE SADDLE
 SMITH-BLAIR 372 OR
 APPROVED EQUAL

NOTE: FOR SERVICES LARGER THAN 1" A TAPPING
 SLEEVE IS REQUIRED. ROCKWELL TYPE 230, FULL
 CIRCLE, WITH TAP THREADED FOR APPROPRIATE
 SIZE COPPER CORPORATION STOP. (OR EQUAL)

CORPORATION STOP
 MUELLER B-25000-N
 FORD FB-600-4-NL OR-6-NL
 A.Y. MCDONALD 74701-B

CURB STOP
 MUELLER B-25154-N
 FORD B22-444M-NL OR-666M-NL
 A.Y. MCDONALD 76104

CURB BOX
 MUELLER H-10300-N OR H-10302-N
 FORD EM2-75-56R-NL OR EM2-75-57R-NL
 A.Y. MCDONALD 75615 OR 75614

- NOTES:**
1. CURB BOX SHALL HAVE A STATIONARY ROD
 2. CURB BOX SHALL EXTEND FROM 78" TO 90".
 3. ALL PIPE SHALL BE BEDDED IN GRANULAR BORROW 3149.2B1 EXCEPT THE LAST TEN FEET WHERE COARSE FILTER AGGREGATE (3149.2H) WILL BE REQUIRED.
 4. IF CURB STOP IS IN DRIVEWAY, CONTRACTOR MUST INSTALL A FORD A-1 CASTING, MARKED WITH "WATER" ON LID.
 5. CURB BOX LID SHALL BE MUELLER #89375 OR EQUAL.
 6. ALL BRASS FITTINGS SHALL BE "NO LEAD BRASS"



2335 Highway 36 W
 St. Paul, MN 55113
 www.stantec.com

**WATER SERVICE CONNECTION
 COPPER PIPE
 CHASKA, MINNESOTA**

LAST REVISION:
 MARCH 2016

PLATE NO.
SER-2

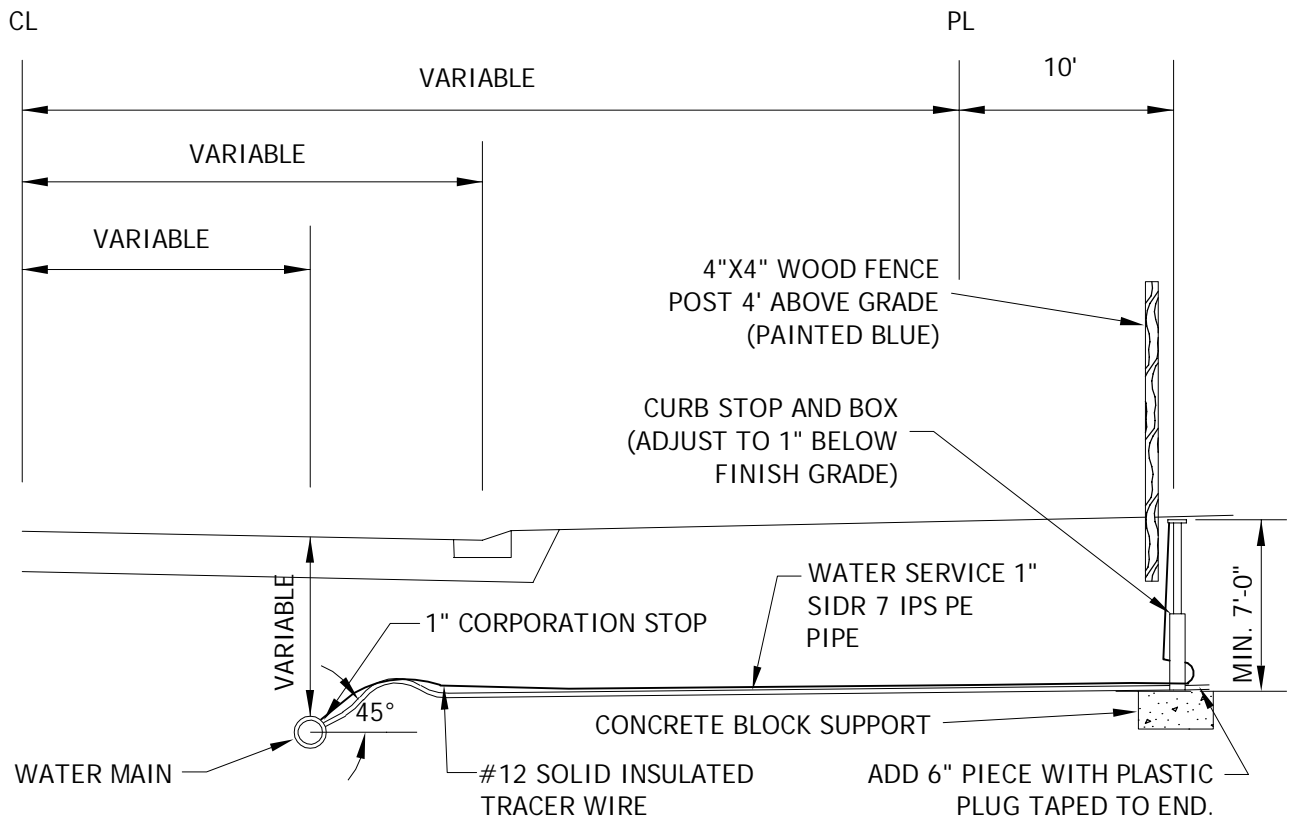

PVC WATER MAIN
 STAINLESS STEEL
 SERVICE SADDLE
 SMITH-BLAIR 372 OR
 APPROVED EQUAL

NOTE: FOR SERVICES LARGER THAN 1" A TAPPING
 SLEEVE IS REQUIRED. ROCKWELL TYPE 230, FULL
 CIRCLE, WITH TAP THREADED FOR APPROPRIATE
 SIZE COPPER CORPORATION STOP. (OR EQUAL)

CORPORATION STOP
 MUELLER B25009N
 FORD FB1001-4Q
 A.Y. MCDONALD 74701B-3Q

CURB STOP
 MUELLER B25222N
 FORD B66444MQ
 A.Y. MCDONALD 76104-3Q

CURB BOX
 MUELLER H-10300-N OR H-10302-N
 FORD EM2-75-56R-NL OR EM2-75-57R-NL
 A.Y. MCDONALD 75615 OR 75614

- NOTES:**
1. CURB BOX SHALL HAVE A STATIONARY ROD.
 2. CURB BOX SHALL EXTEND FROM 78" TO 90".
 3. ALL PIPE SHALL BE BEDDED IN GRANULAR BORROW 3149.2B1 EXCEPT THE LAST TEN FEET WHERE COARSE FILTER AGGREGATE (3149.2H) WILL BE REQUIRED.
 4. IF CURB STOP IS IN DRIVEWAY, CONTRACTOR MUST INSTALL A FORD A-1 CASTING, MARKED WITH "WATER" ON LID.
 5. CURB BOX LID SHALL BE MUELLER #89375 "TW" OR EQUAL.
 6. ALL BRASS FITTINGS SHALL BE "NO LEAD BRASS".
 7. PIPE INSERT STIFFENERS REQUIRED FOR FITTING CONNECTIONS.
 8. HDPE SERVICE PIPE SHALL BE MANUFACTURED BY ENDOPURE OR BLUE ULTRA PIPE.



WATER SERVICE CONNECTION
HDPE PIPE
CHASKA, MINNESOTA

LAST REVISION:
 MARCH 2023

PLATE NO.
SER-2A

PVC PIPE
BED AND ENCASE IN SELECT GRANULAR,
TYPICAL PVC APPLICATION.

SERVICE RISERS FOR SEWER MAINS LESS THAN 22' SHALL BE
SCHEDULE 40 PVC (SOLVENT WELD JOINTS).

FOR DEPTHS GREATER THAN 22', SERVICE PIPE SHALL BE
C900 FROM MAIN TO CONNECTION WITH TRANSITION
FITTING FROM C900 TO SCH 40 INSTALLED AT CONNECTION
LOCATION.

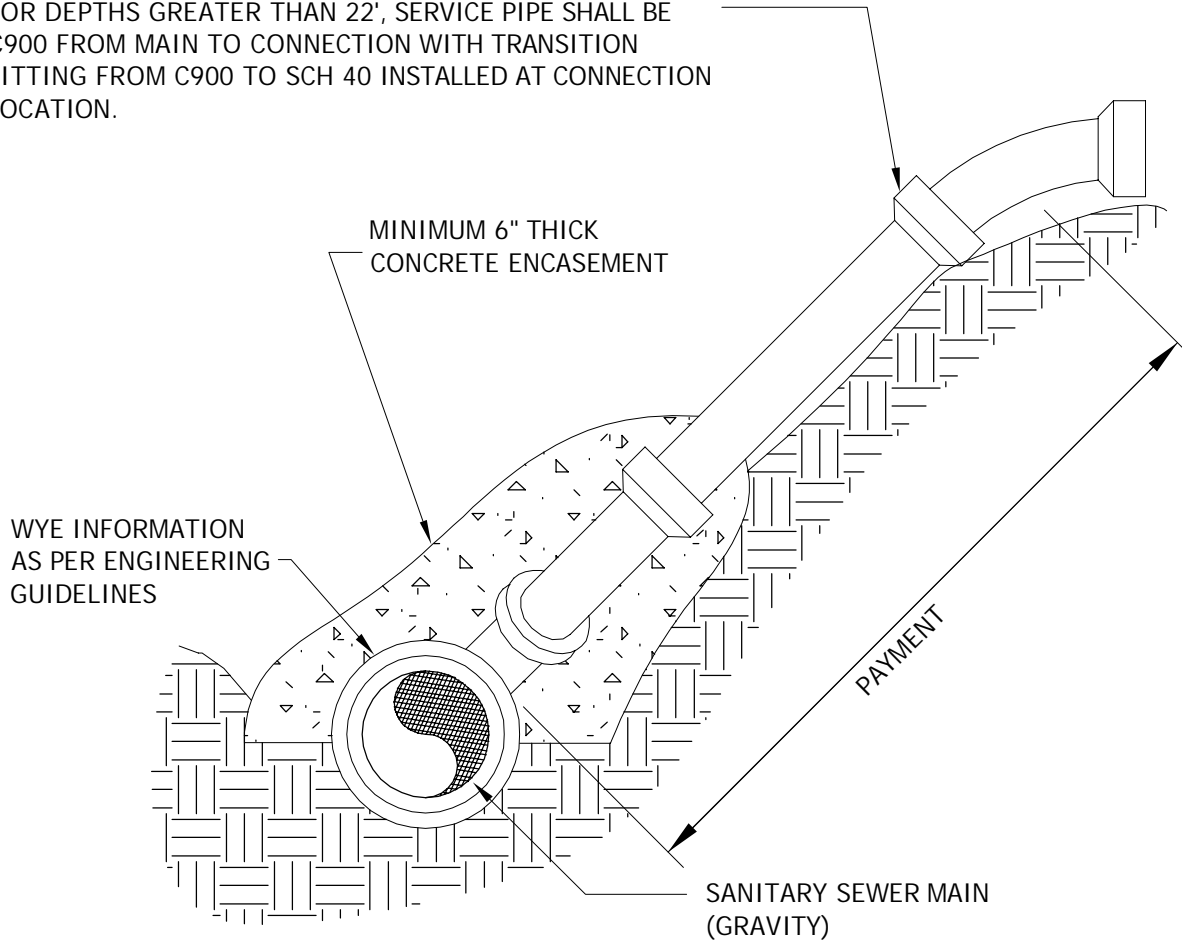

2335 Highway 36 W
St. Paul, MN 55113
www.stantec.com

SERVICE RISER
CHASKA, MINNESOTA

LAST REVISION:
MARCH 2016

PLATE NO.
SER-3

NOTE:
CLEANOUT CAP SHALL BE
THREADED MALLEABLE IRON
(GALVANIZED)

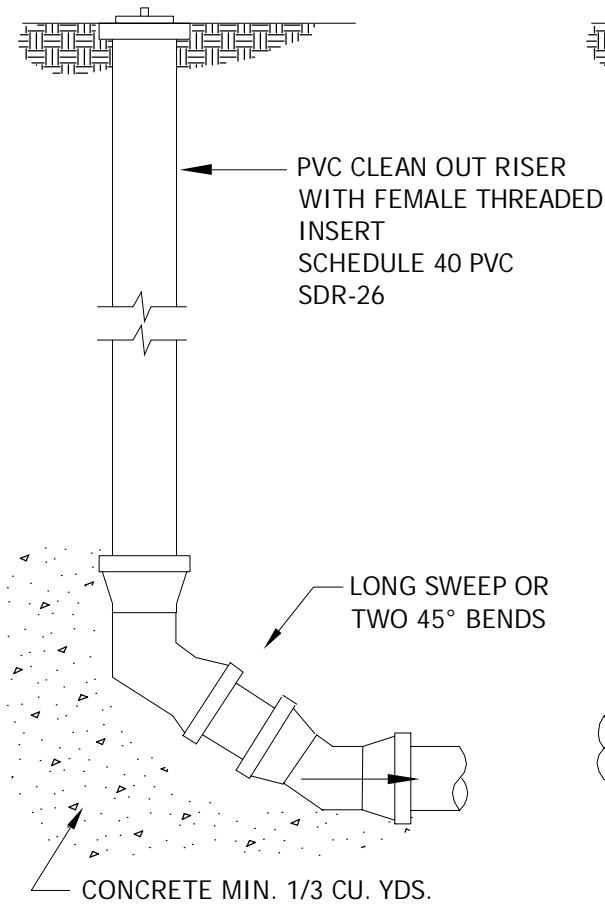

END OF LINE CLEANOUT

NOTE:
ENCLOSE LONG SWEEP BEND
OR COMBINATION WYE IN
CONCRETE AS SHOWN.

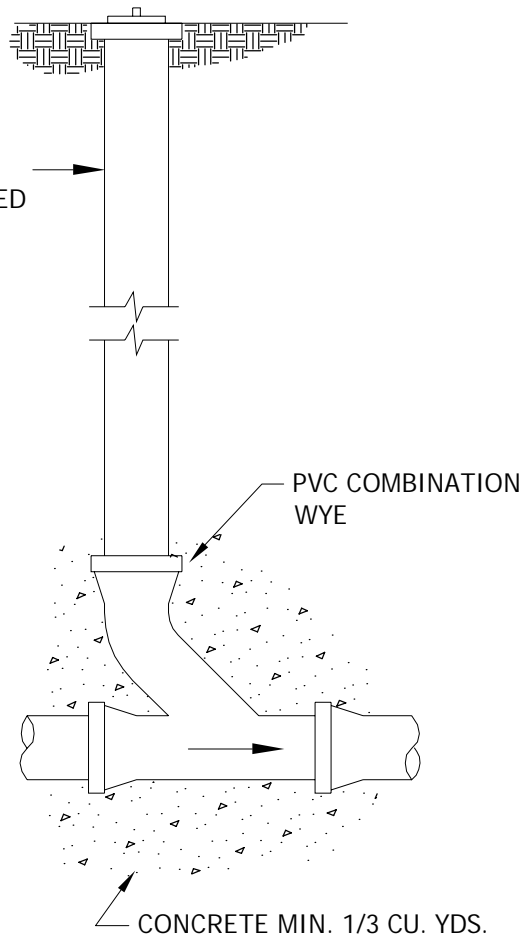

IN LINE CLEANOUT

NOTE:
CLEANOUT IS REQUIRED FOR EVERY
100 FEET OF SERVICE LENGTH.

NOTE:

1. IF CLEAN OUT IS IN DRIVEWAY, CONTRACTOR MUST INSTALL FORD A-1 CASTING, MARKED WITH "SEWER" ON LID.
2. IF VALVE BOX IS IN ROADWAY, CONTRACTOR MUST INSTALL TOP SECTION OF A VALVE BOX WITH LID MARKED "SEWER".



2335 Highway 36 W
St. Paul, MN 55113
www.stantec.com

SERVICE LINE CLEANOUTS

CHASKA, MINNESOTA

LAST REVISION:
MARCH 2001

PLATE NO.
SER-4

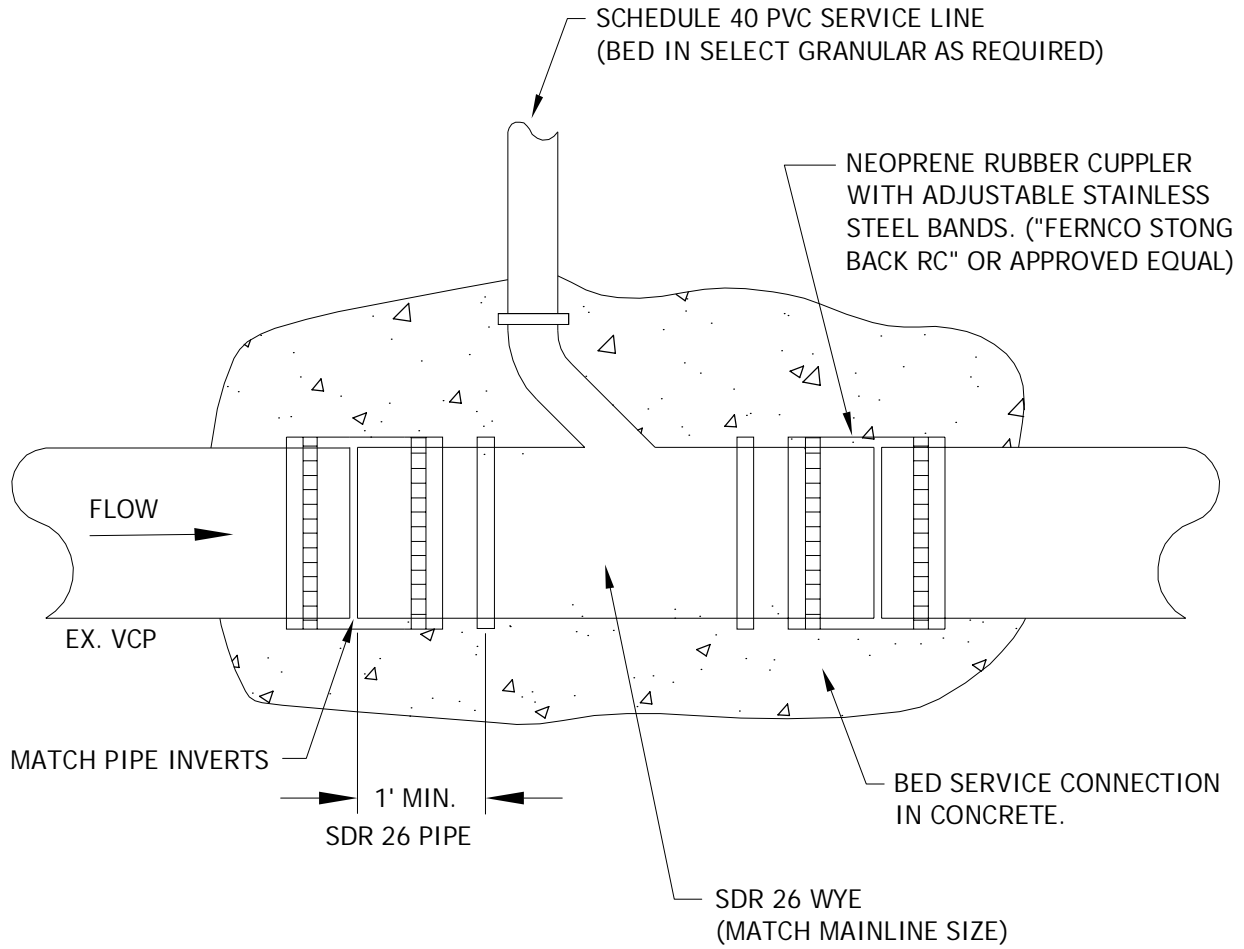

2335 Highway 36 W
St. Paul, MN 55113
www.stantec.com

VCP SEWER SERVICE CUT-IN

CHASKA, MINNESOTA

LAST REVISION:
APRIL 2016

PLATE NO.
SER-5

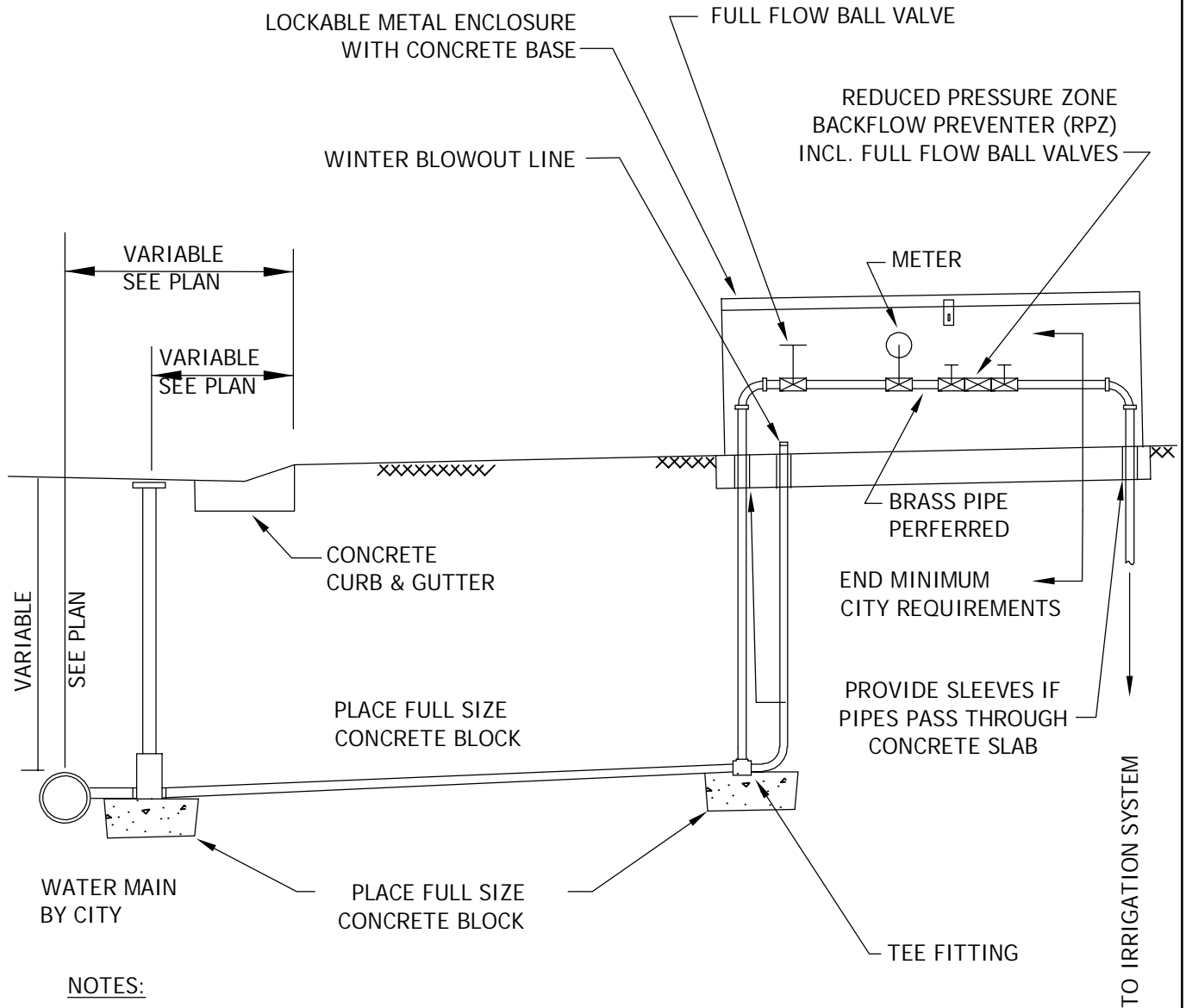

NOTES:

1. CITY WATER SERVICE & PLUMBING PERMITS REQUIRED FOR WORK BY PRIVATE CONTRACTORS.
2. ANNUAL TESTING OF RPZ REQUIRED
3. REQUIRED EQUIPMENT MUST BE ENCLOSED AND SUPPORTED.
4. ENCLOSURE MUST BE APPROVED BY CITY WATER DEPT. ENCLOSURE MUST BE LOCKED WITH A HEAVY DUTY PADLOCK. (SUPPLIED BY CITY)
5. SLEEVES FOR PIPES IN CONCRETE SLABS SHALL BE 4" DIAMETER PVC OR SIMILAR.
6. IF A 1-1/2" IRRIGATION SERVICE IS USED THEN THE CURBSTOP MUST BE LOCATED IN THE GREEN AREA.



2335 Highway 36 W
 St. Paul, MN 55113
 www.stantec.com

**IRRIGATION SERVICE
 BY PRIVATE CONTRACTOR**

CHASKA, MINNESOTA

LAST REVISION:
 MARCH 2018

PLATE NO.
 SER-6

Plot Date: 03/06/2018
 Drawing name: C:\Users\kchamrath\OneDrive\Documents\stentec\chaska\210465\TO-1.dwg
 User:

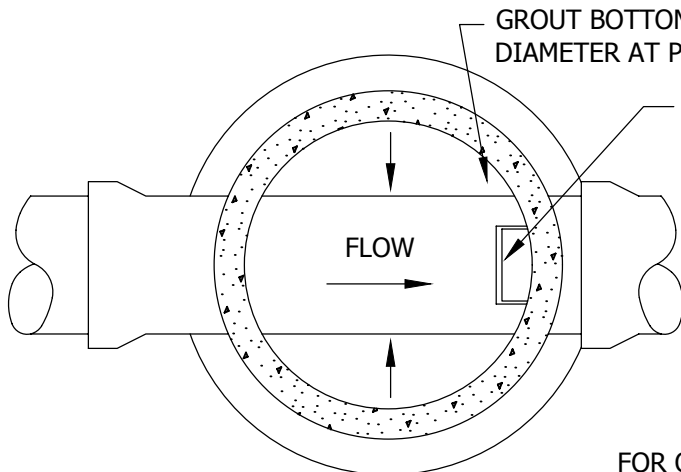

PLAN

MANHOLE STEPS SHALL BE PLACED SO THAT OFFSET VERTICAL PORTION OF CONE IS FACING DOWNSTREAM FOR ALL LINES UP TO 24". PLACE STEPS ON RIGHT HAND SIDE WHEN FACING DOWN STREAM FOR ALL 24" AND OVER.

FRAME	A	B
R1642-2310B	27"	7"

FOR OFF-ROAD SITUATIONS, USE R1916F CASTING MARKED "STORM SEWER". COVERS MUST BE SECURED TO PREVENT REMOVAL.

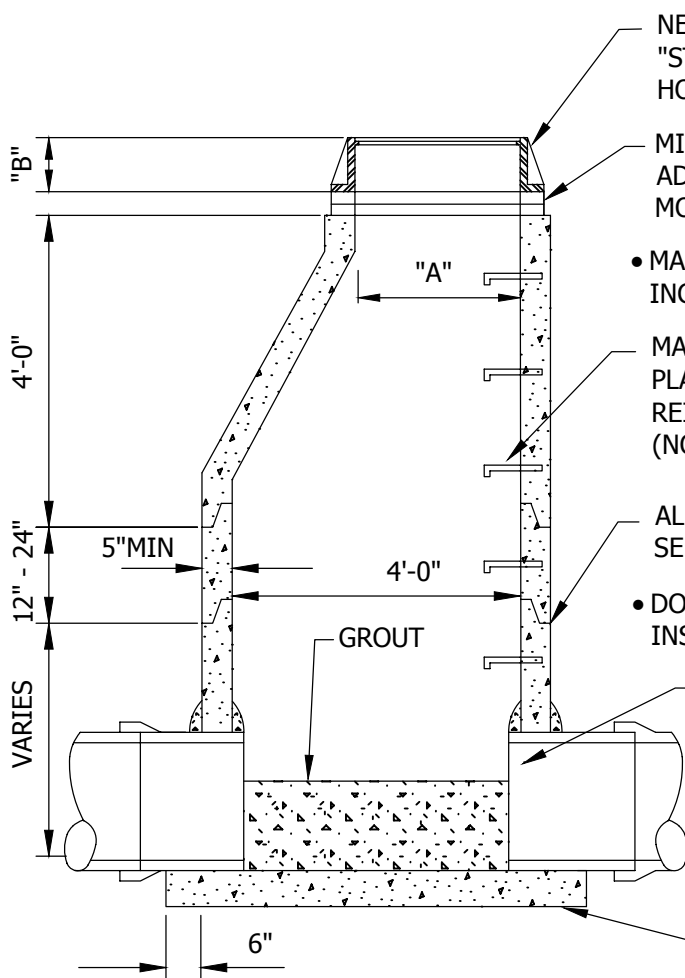

SECTION

NEENAH COVER **R1642-5040** LETTERED, "STORM SEWER", WITH 2 CONCEALED PICK HOLES.

MINIMUM OF 2 MAXIMUM OF 4 CONCRETE ADJUSTMENT RINGS WITH FULL BED OF MORTAR BETWEEN EACH RING.

- MAXIMUM 20" ADJUSTMENT ALLOWED INCLUDING RINGS AND CASTING.

MANHOLE STEPS, COPOLYMER POLYPROPYLENE PLASTIC, WITH 1/2" GRADE 60 STEEL REINFORCEMENT OR EQUAL, 16" ON CENTER. (NO STEPS ALLOWED IN UPPER 27" BARREL.)

ALL JOINTS IN MANHOLE TO HAVE SELF LUBRICATING RUBBER GASKETS.

- DOG HOUSES MUST BE GROUTED BOTH INSIDE AND OUTSIDE OF STRUCTURE.

PIPE SHALL BE CUT OUT 2" FROM INSIDE FACE OF WALL.

- NOTE: KOR-N-SEAL MANHOLE OR EQUAL CONSIDERED ACCEPTABLE ALTERNATE.

- NOTE: A MINIMUM SLOPE OF 1% IS REQUIRED ACROSS THE INVERT.

MINIMUM SLAB THICKNESS, 6" TO 14' DEPTH. INCREASE THICKNESS 1" FOR EACH 4' OF DEPTH GREATER THAN 14', AND REINFORCE WITH PER MNDOT STD 4011



2335 Highway 36 W
 St. Paul, MN 55113
 www.stantec.com

STORM SEWER MANHOLE

CHASKA, MINNESOTA

LAST REVISION:
 MARCH 2018

PLATE NO.
STO-1

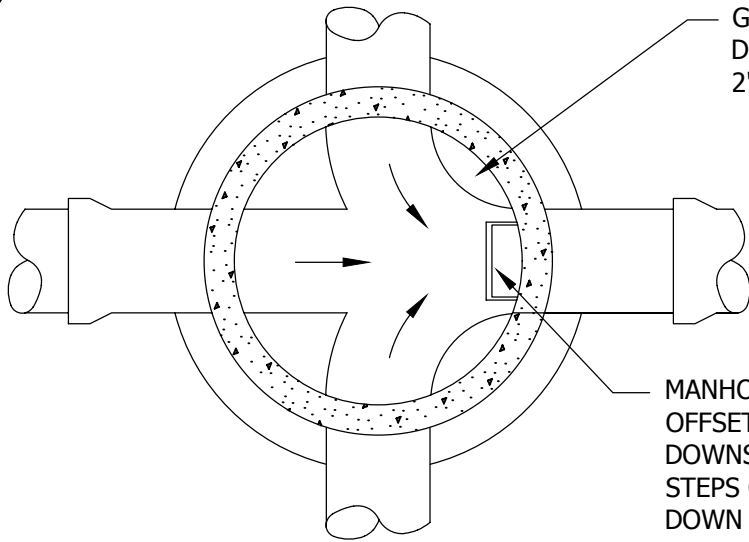

GROUT BOTTOM OF MANHOLE TO 1/2 DIAMETER AT PIPE AND SLOPE GROUT 2" TOWARD INVERT.

FRAME	A	B
R1642-2310B	27"	7"

FOR OFF-ROAD SITUATIONS, USE R1916F CASTING MARKED "STORM SEWER", WITH 2 CONCEALED PICK HOLES.

MANHOLE STEPS SHALL BE PLACED SO THAT OFFSET VERTICAL PORTION OF CONE IS FACING DOWNSTREAM FOR ALL LINES UP TO 24". PLACE STEPS ON RIGHT HAND SIDE WHEN FACING DOWN STREAM FOR ALL 24 " AND OVER.

PLAN

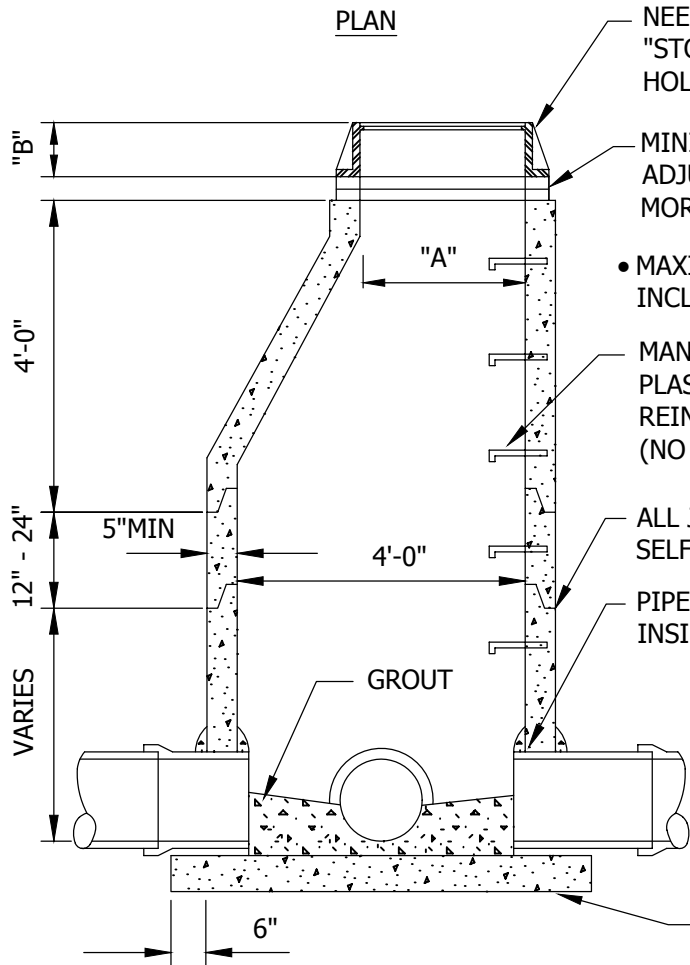

NEENAH COVER **R1642-5040**, LETTERED, "STORM SEWER", WITH 2 CONCEALED PICK HOLES.

MINIMUM OF 2 MAXIMUM OF 4 CONCRETE ADJUSTMENT RINGS WITH FULL BED OF MORTAR BETWEEN EACH RING.

- MAXIMUM 20" ADJUSTMENT ALLOWED INCLUDING RINGS AND CASTING.

MANHOLE STEPS, COPOLYMER POLYPROPYLENE PLASTIC, WITH 1/2" GRADE 60 STEEL REINFORCEMENT OR EQUAL, 16" ON CENTER. (NO STEP ALLOWED IN UPPER 27" BARREL.)

ALL JOINTS IN MANHOLE TO HAVE SELF LUBRICATING RUBBER GASKETS.

PIPE SHALL BE CUT OUT 2" FROM INSIDE FACE OF WALL.

- NOTE: A MINIMUM SLOPE OF 1% IS REQUIRED ACROSS THE INVERT.

- NOTE: KOR-N-SEAL MANHOLE OR EQUAL CONSIDERED ACCEPTABLE ALTERNATE.

- DOG HOUSES MUST BE GROUTED BOTH INSIDE AND OUTSIDE OF STRUCTURE.

MINIMUM SLAB THICKNESS, 6" TO 14' DEPTH. INCREASE THICKNESS 1" FOR EACH 4' OF DEPTH GREATER THAN 14', AND REINFORCE WITH PER MNDOT STD 4011

SECTION



2335 Highway 36 W
 St. Paul, MN 55113
 www.stantec.com

STORM SEWER JUNCTION MANHOLE

CHASKA, MINNESOTA

LAST REVISION:
 MARCH 2018

PLATE NO.
 STO-2

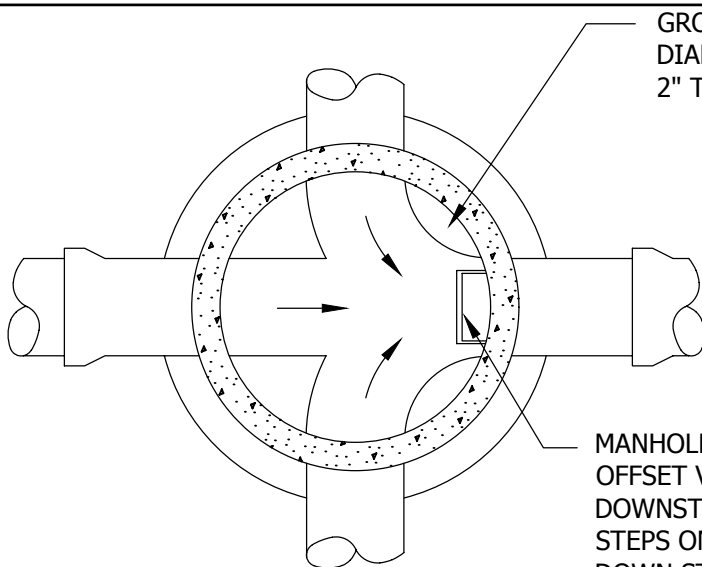

GROUT BOTTOM OF MANHOLE TO 1/2 DIAMETER AT PIPE AND SLOPE GROUT 2" TOWARD INVERT.

FRAME	A	B
R1642-2310B	27"	7"

FOR OFF-ROAD SITUATIONS, USE R1916F CASTING MARKED "STORM SEWER", WITH TWO CONCEALED PICK HOLES.

MANHOLE STEPS SHALL BE PLACED SO THAT OFFSET VERTICAL PORTION OF CONE IS FACING DOWNSTREAM FOR ALL LINES UP TO 24". PLACE STEPS ON RIGHT HAND SIDE WHEN FACING DOWN STREAM FOR ALL 24 " AND OVER.

PLAN

MINIMUM OF 2 MAXIMUM OF 4 CONCRETE ADJUSTMENT RINGS WITH FULL BED OF MORTAR BETWEEN EACH RING.

NEENAH COVER **R1642-5040** OR EQUAL, LETTERED, "STORM SEWER", WITH 2 CONCEALED PICK HOLES.

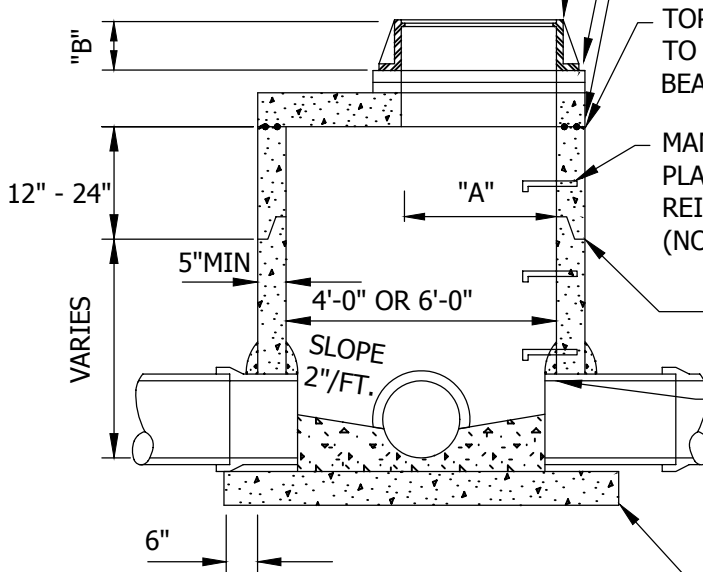

• MAXIMUM 20" ADJUSTMENT ALLOWED INCLUDING RINGS AND CASTING.

6" PRECAST REINFORCED CONCRETE MANHOLE SLAB WITH MINIMUM #4 BARS AT 5" O.C. EACH WAY AND 2-#4 BARS AT ALL SIDES OF OPENING. FOR 6' DIA. MANHOLE, A MINIMUM 8" PRECAST SLAB IS REQUIRED.

TOP OF BARREL SECTION BELOW TOP SLAB TO HAVE FLAT TOP EDGE SEALED WITH 2 BEADS OF RAMNEK OR EQUAL.

MANHOLE STEPS, COPOLYMER POLYPROPYLENE PLASTIC, WITH 1/2" GRADE 60 STEEL REINFORCEMENT OR EQUAL, 16" ON CENTER. (NO STEP ALLOWED IN UPPER 27" BARREL.)

ALL JOINTS IN MANHOLE TO HAVE SELF LUBRICATING RUBBER GASKETS.

PIPE SHALL BE CUT OUT 2" FROM INSIDE FACE OF WALL.

• DOGHOUSES MUST BE GROUTED BOTH INSIDE AND OUTSIDE.

MINIMUM SLAB THICKNESS, 6" TO 14' DEPTH. INCREASE THICKNESS 1" FOR EACH 4' OF DEPTH GREATER THAN 14', AND REINFORCE WITH PER MNDOT STD 4011

SECTION

NOTE: A MINIMUM SLOPE OF 1% IS REQUIRED ACROSS THE INVERT.



2335 Highway 36 W
 St. Paul, MN 55113
 www.stantec.com

STORM SEWER JUNCTION MANHOLE
 WITH REINFORCED TOP SLAB

CHASKA, MINNESOTA

LAST REVISION:
 MARCH 2018

PLATE NO.
 STO-3

Plot Date: 03/06/2018
 Drawing name: C:\Users\schwarz\Documents\stc\stc\temp\1407.dwg
 User: schwarz

FRAME	A	B
R1642-2310B	27"	7"

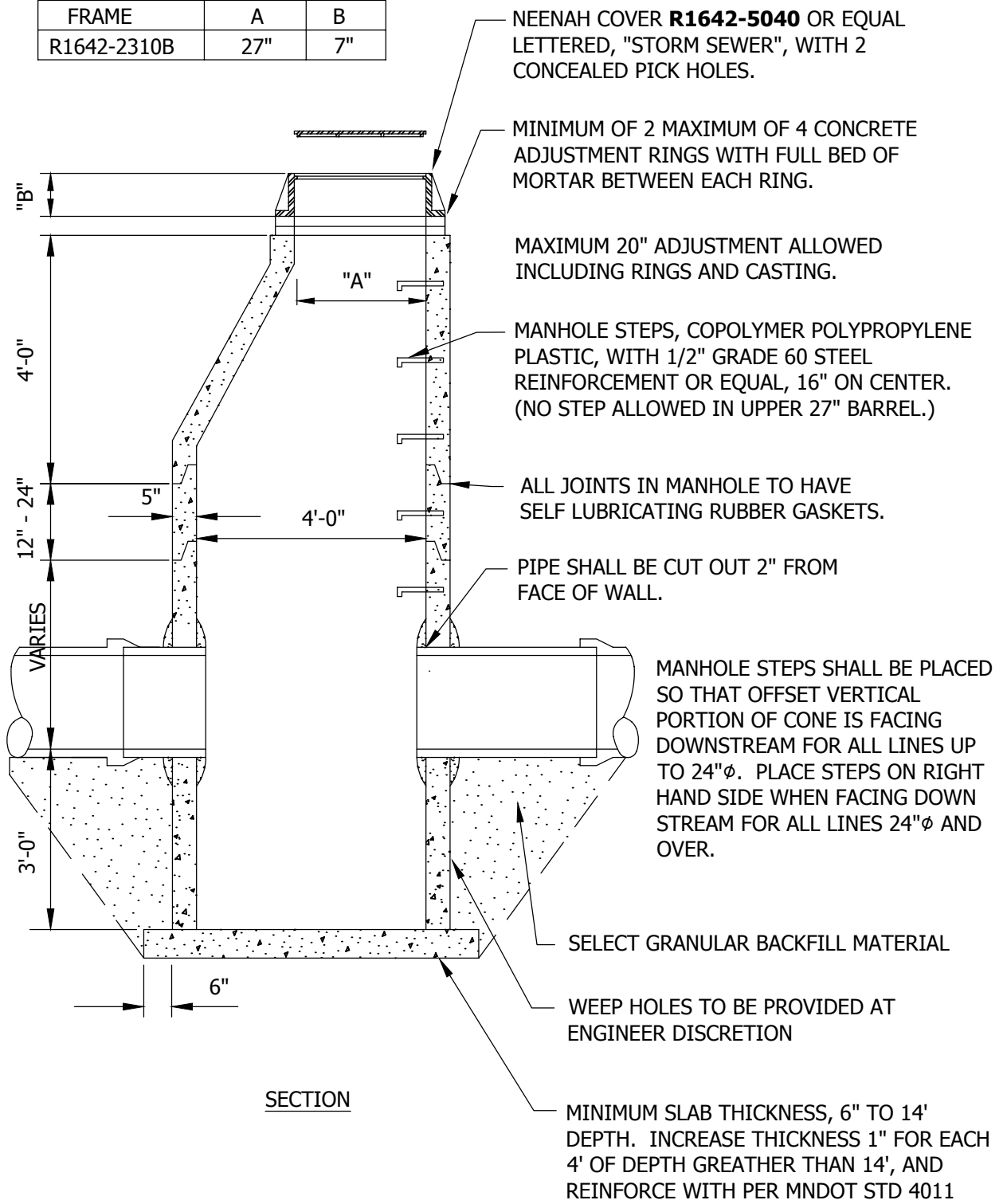

2335 Highway 36 W
 St. Paul, MN 55113
 www.stantec.com

PERFORATED SUMP MANHOLE

CHASKA, MINNESOTA

LAST REVISION:
 MARCH 2018

PLATE NO.
 STO-4

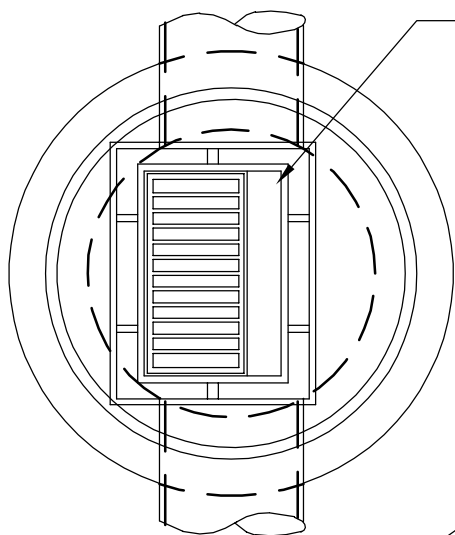

24"X36" SLAB OPENING FOR NEENAH R3067V OR ESS. BROS. 330 HIGH CAPACITY OR EQUAL. INSTALL R3501-TR/TL FOR DRIVEWAYS AND VALLEY GUTTERS. INSTALL R3501-TB BI-DIRECTIONAL AT LOW POINTS. (VANE GRATE SHOWN)

DIMENSION FROM BACK OF CURB TO CENTER OF PIPE.
 4' DIA. MH - 9" IN FROM BACK OF CURB
 5' DIA. MH - 3" IN FROM BACK OF CURB
 6' DIA. MH - 3" BEHIND BACK OF CURB
 7' DIA. MH - 9" BEHIND BACK OF CURB
 8' DIA. MH - 15" BEHIND BACK OF CURB

PLAN

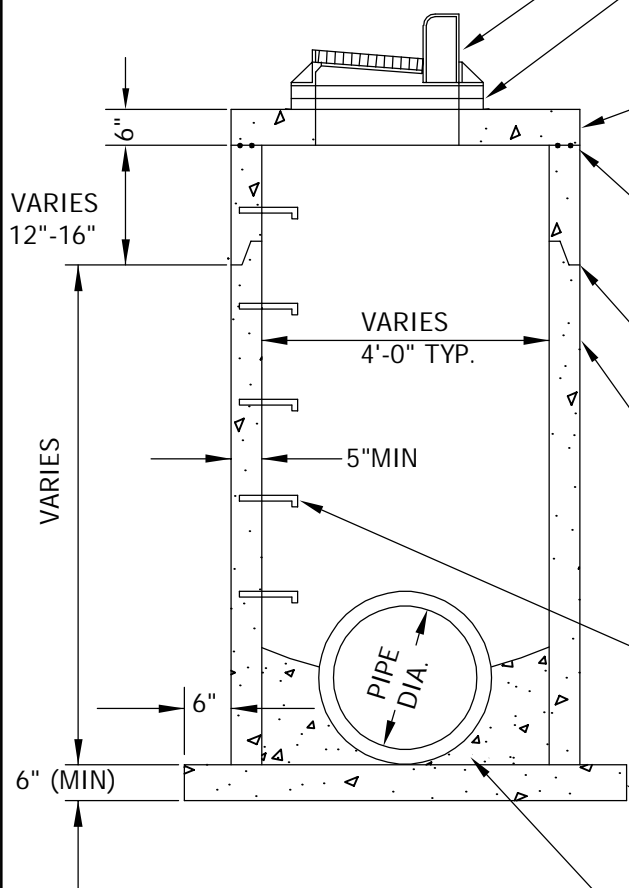

MORTAR BOLT HOLES IN BACK OF FRAME.
 MINIMUM OF 2 MAXIMUM OF 4 CONCRETE ADJUSTMENT RINGS WITH FULL BED OF MORTAR BETWEEN EACH RING.

6" PRECAST REINFORCED CONCRETE SLAB. FOR 6' DIA. MANHOLE, AN 8" PRECAST SLAB IS REQUIRED.

TOP OF BARREL SECTION UNDER TOP SLAB TO HAVE FLAT TOP EDGE SEALED WITH 2 BEADS OF RAMNEK OR EQUAL.

ALL JOINTS IN MANHOLE TO HAVE SELF LUBRICATING RUBBER GASKETS.

PRECAST CONCRETE SECTION

DOGHOUSES SHALL BE GROUTED ON BOTH THE OUTSIDE AND INSIDE.

MANHOLE STEPS SHALL BE PLACED BELOW THE DOWNSTREAM CORNER OF THE OPENING NEAREST THE STREET.

MINIMUM SLAB THICKNESS, 6" TO 14' DEPTH. INCREASE THICKNESS 1" FOR EACH 4' OF DEPTH GREATER THAN 14', AND REINFORCE WITH PER MNDOT STD 4011

GROUT BOTTOM

SECTION



2335 Highway 36 W
 St. Paul, MN 55113
 www.stantec.com

**TYPE II
 CATCHBASIN MANHOLE**

CHASKA, MINNESOTA

LAST REVISION:
 MARCH 2023

PLATE NO.
 STO-5

Plot Date: 03/07/2018
Drawing Name: R:\cadd\ba\plates\2018 Detail Plates\STO-5A.dwg
Xref:

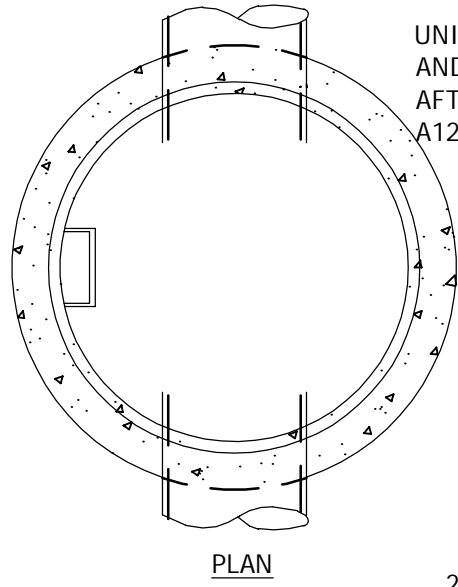

UNIT IS MADE FROM A36 STEEL AND IS HOT DIP GALVANIZED AFTER FABRICATION PER ASTM A123.

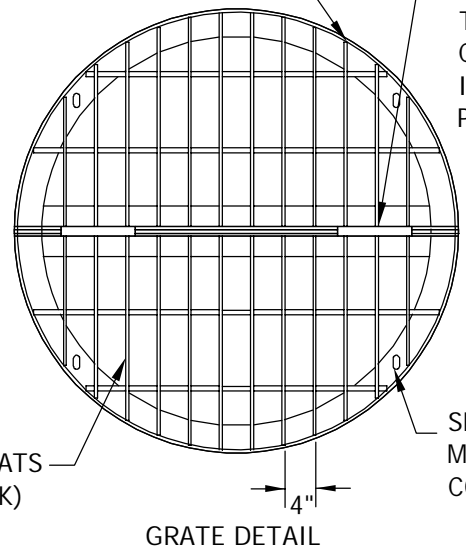

HEAVY DUTY HINGES SO THAT GRATE CAN BE SPLIT INTO 2 PIECES

2" TALL FLATS (3/8" THICK)

SLOTS FOR MOUNTING TO CONCRETE

GRATE DETAIL

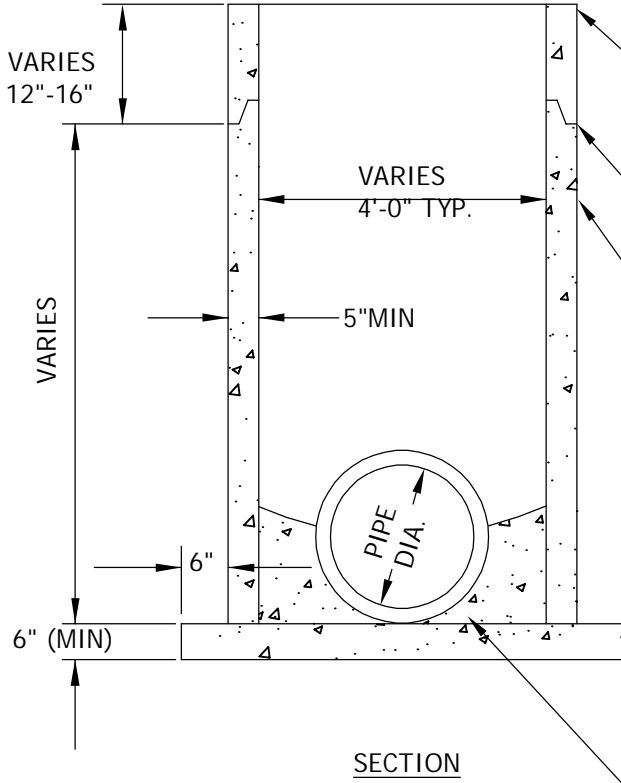

TOP OF BARREL SECTION UNDER TOP SLAB TO HAVE FLAT TOP EDGE SEALED WITH 2 BEADS OF RAMNEK OR EQUAL.

ALL JOINTS IN MANHOLE TO HAVE SELF LUBRICATING RUBBER GASKETS.

PRECAST CONCRETE SECTION

DOGHOUSES SHALL BE GROUTED ON BOTH THE OUTSIDE AND INSIDE.

MINIMUM SLAB THICKNESS, 6" TO 14' DEPTH. INCREASE THICKNESS 1" FOR EACH 4' OF DEPTH GREATER THAN 14', AND REINFORCE WITH PER MNDOT STD 4011

GROUT BOTTOM

SECTION

**TYPE II
CATCHBASIN MANHOLE
POND SKIMMER
CARVER, MINNESOTA**

LAST REVISION:
MARCH 2018

PLATE NO.
STO-5A

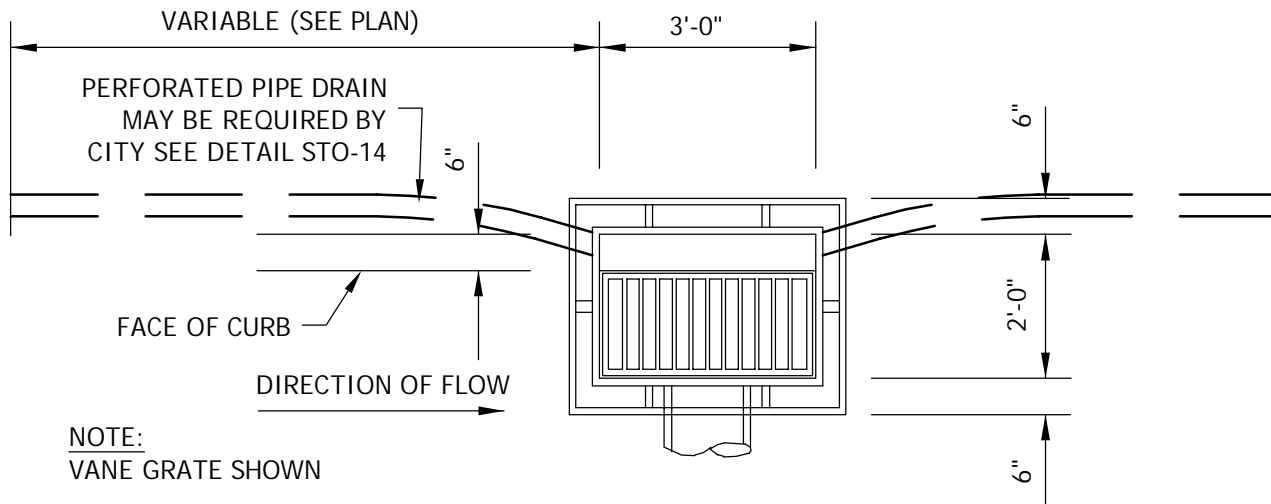

NOTE:
VANE GRATE SHOWN

PLAN

CATCHBASIN CASTING NEENAH R3067V OR
 ESS. BRO. 330 HIGH CAPACITY OR EQUAL
 WITH VANE GRATE 3" RADIUS CURB BOX.
 INSTALL R3501-TR/TL CASTING IN
 DRIVEWAYS AND VALLEY GUTTERS.
 INSTALL R3501-TB BI-DIRECTIONAL AT
 LOW POINTS.

MORTAR BOLT HOLES IN BACK OF FRAME.

GRATE IN GUTTERLINE TO BE 2"
 BELOW GUTTER GRADE. 10'
 TRANSITION EACH SIDE OF CATCH
 BASIN.

MIN. OF 2 MAX. OF 4
 CONCRETE ADJUSTMENT RINGS
 WITH FULL BED OF GROUT
 BETWEEN EACH RING.

MAXIMUM 20" ADJUSTMENT ALLOWED
 INCLUDING RINGS AND CASTING.

DOGHOUSES SHALL BE GROUTED
 ON BOTH THE OUTSIDE AND
 THE INSIDE.

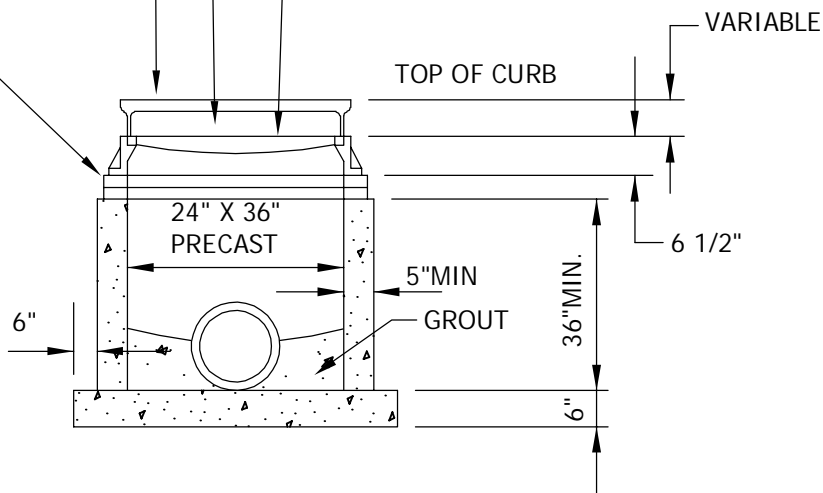

SECTION



2335 Highway 36 W
 St. Paul, MN 55113
 www.stantec.com

**TYPE II
CATCHBASIN**

CHASKA, MINNESOTA

LAST REVISION:
 MARCH 2023

PLATE NO.
 STO-6

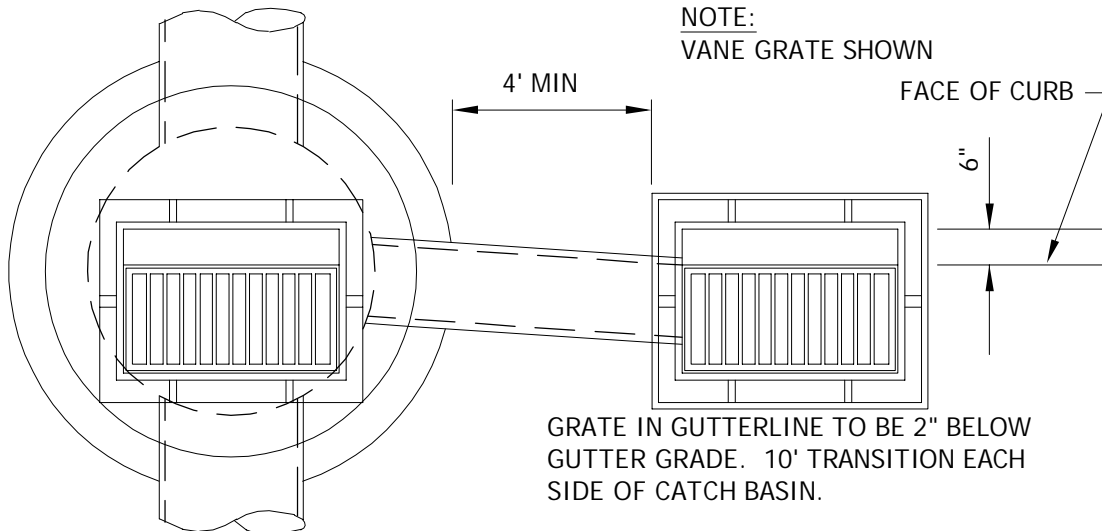

GRATE IN GUTTERLINE TO BE 2" BELOW GUTTER GRADE. 10' TRANSITION EACH SIDE OF CATCH BASIN.

DOGHOUSES SHALL BE GROUTED ON BOTH THE OUTSIDE AND THE INSIDE.

CATCHBASIN CASTING NEENAH R3067V OR ESS.BRO.330 HIGH CAPACITY OR EQUAL WITH VANE GRATE. 3" RADIUS CURB BOX. INSTALL R3501-TR/TL CASTING FOR DRIVEWAYS AND VALLEY GUTTERS. INSTALL R3501-TB BI-DIRECTIONAL AT LOW POINTS.

MIN. OF 2 MAX. OF 4 CONCRETE ADJUSTMENT RINGS WITH FULL BED OF GROUT BETWEEN EACH RING.

MORTAR BOLT HOLES IN BACK OF FRAME.

MAXIMUM 20" ADJUSTMENT ALLOWED INCLUDING RINGS AND CASTING.

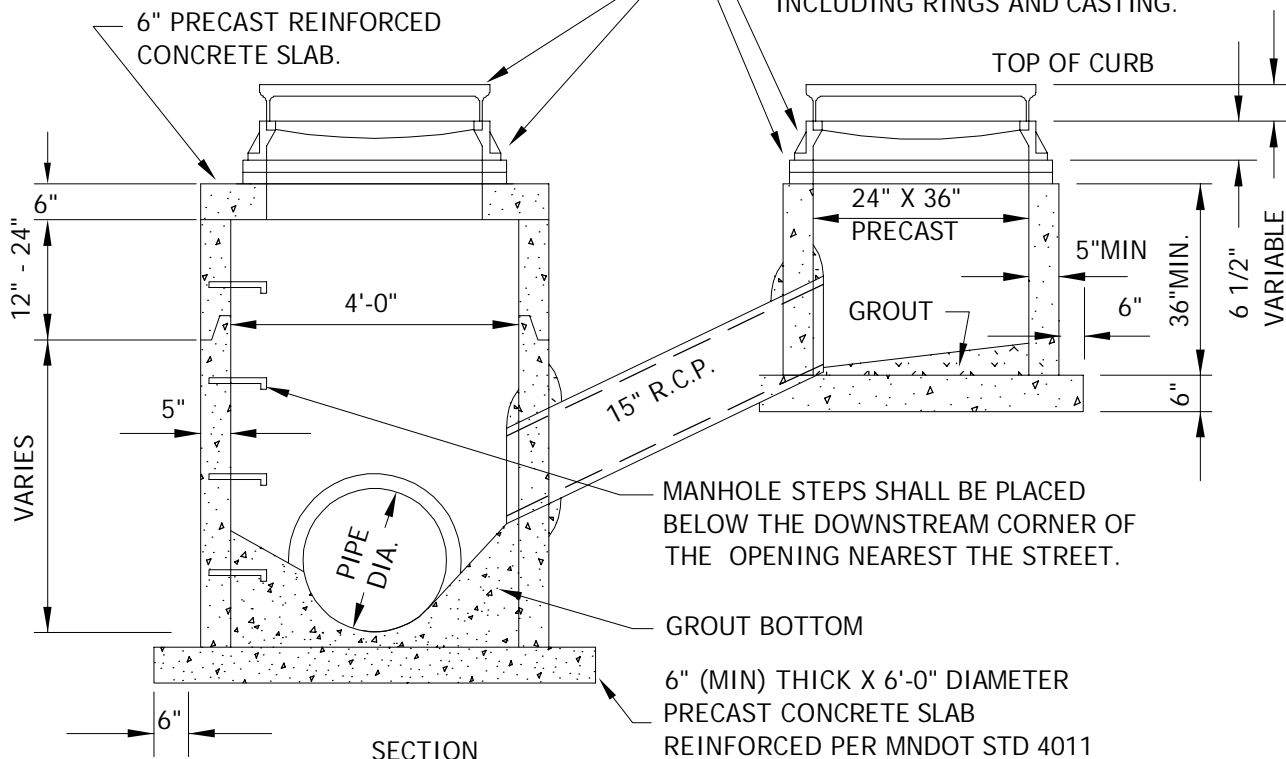

2335 Highway 36 W
 St. Paul, MN 55113
 www.stantec.com

**DOUBLE CATCHBASIN
 TYPE II CBMH WITH TYPE II CB**

CHASKA, MINNESOTA

LAST REVISION:
 MARCH 2023

PLATE NO.
STO-7

NOTE:
VANE GRATE SHOWN

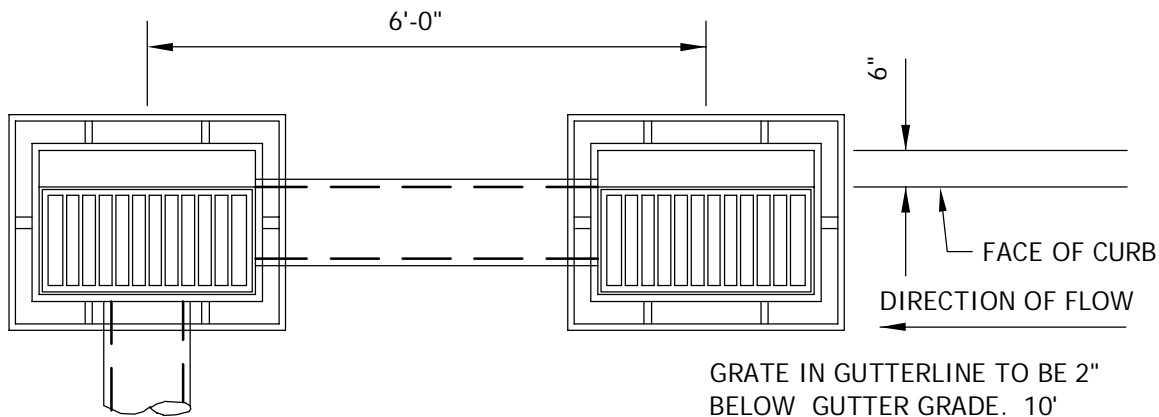

GRATE IN GUTTERLINE TO BE 2" BELOW GUTTER GRADE. 10" TRANSITION EACH SIDE OF CATCH BASIN.

PLAN

CATCHBASING CASTING NEENAH R3067V OR ESS.BRO.330 HIGH CAPACITY OR EQUAL WITH VANE GRATE 3" RADIUS CURB BOX. INSTALL R3501-TB BI-DIRECTIONAL AT LOW POINTS.

MIN. OF 2 MAX. OF 4 CONCRETE ADJUSTMENT RINGS WITH FULL BED OF GROUT BETWEEN EACH RING.

MAXIMUM 20" ADJUSTMENT ALLOWED INCLUDING RINGS AND CASTING.

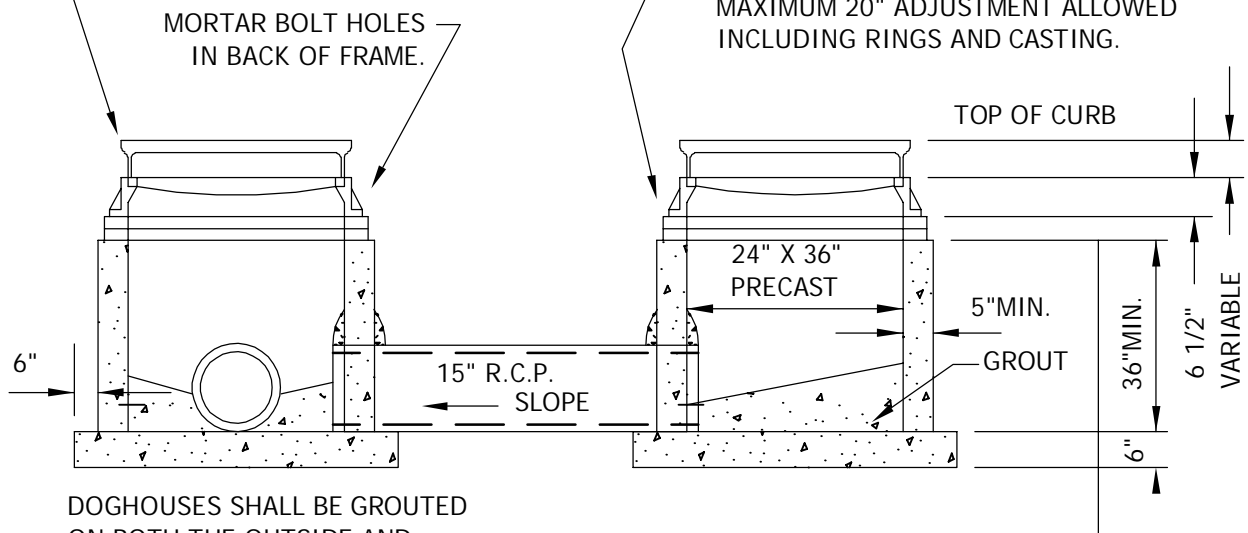

DOGHOUSES SHALL BE GROUTED ON BOTH THE OUTSIDE AND THE INSIDE.

SECTION



2335 Highway 36 W
 St. Paul, MN 55113
 www.stantec.com

**DOUBLE TYPE II
 CATCHBASIN**

CHASKA, MINNESOTA

LAST REVISION:
 MARCH 2023

PLATE NO.
STO-8

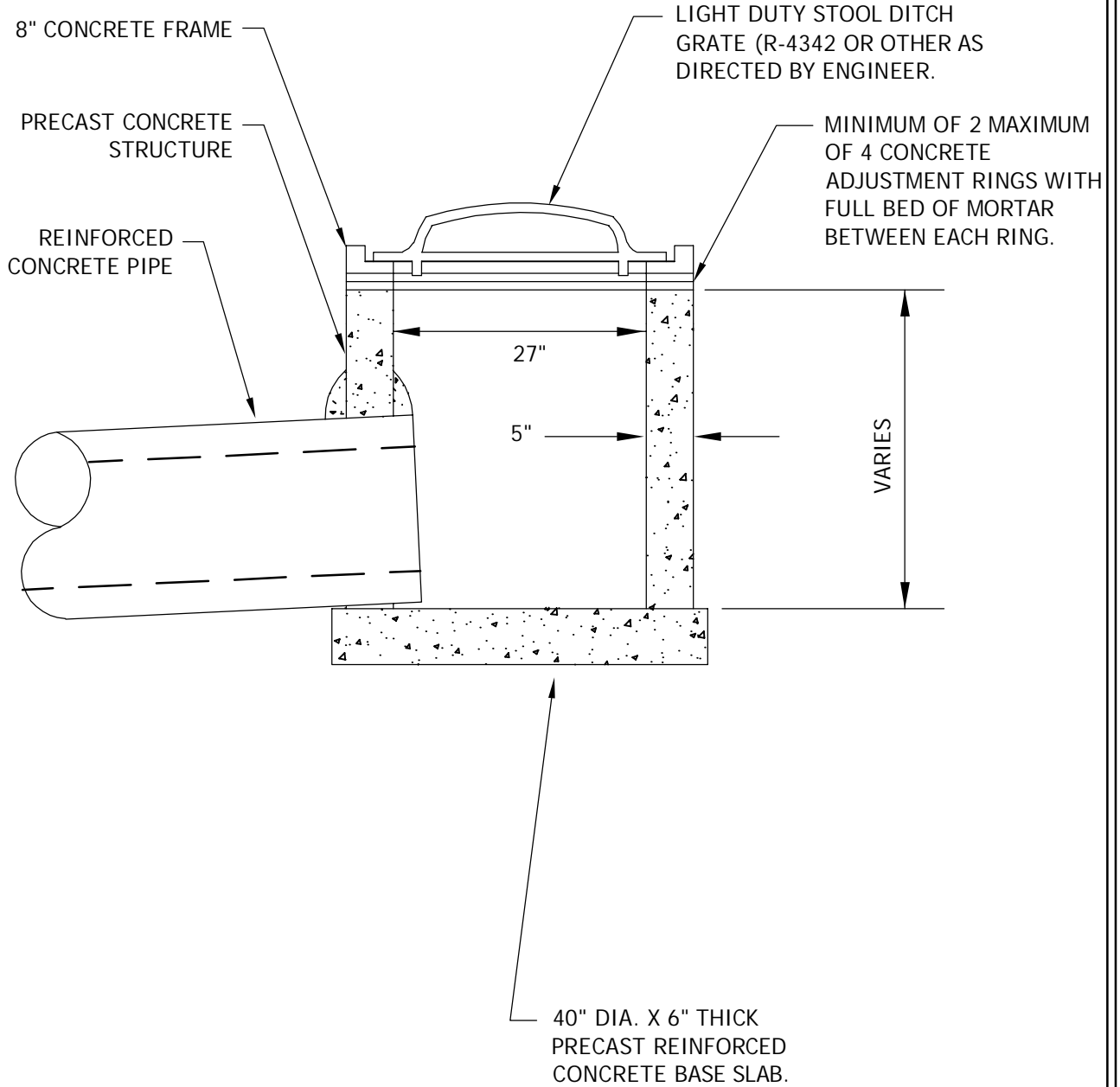

2335 Highway 36 W
St. Paul, MN 55113
www.stantec.com

PRECAST 27" SHALLOW
DEPTH BEEHIVE

CHASKA, MINNESOTA

LAST REVISION:
MAY 2023

PLATE NO.
STO-9

Plot Date: 05/11/2023
 Plotting Name: \\s0291\ps0501\special\handdrawn\plate02 - Chaska.dwg
 User: X:\ps

SEE CITY PLATE NO. STO-11 FOR RIPRAP PLACEMENT.

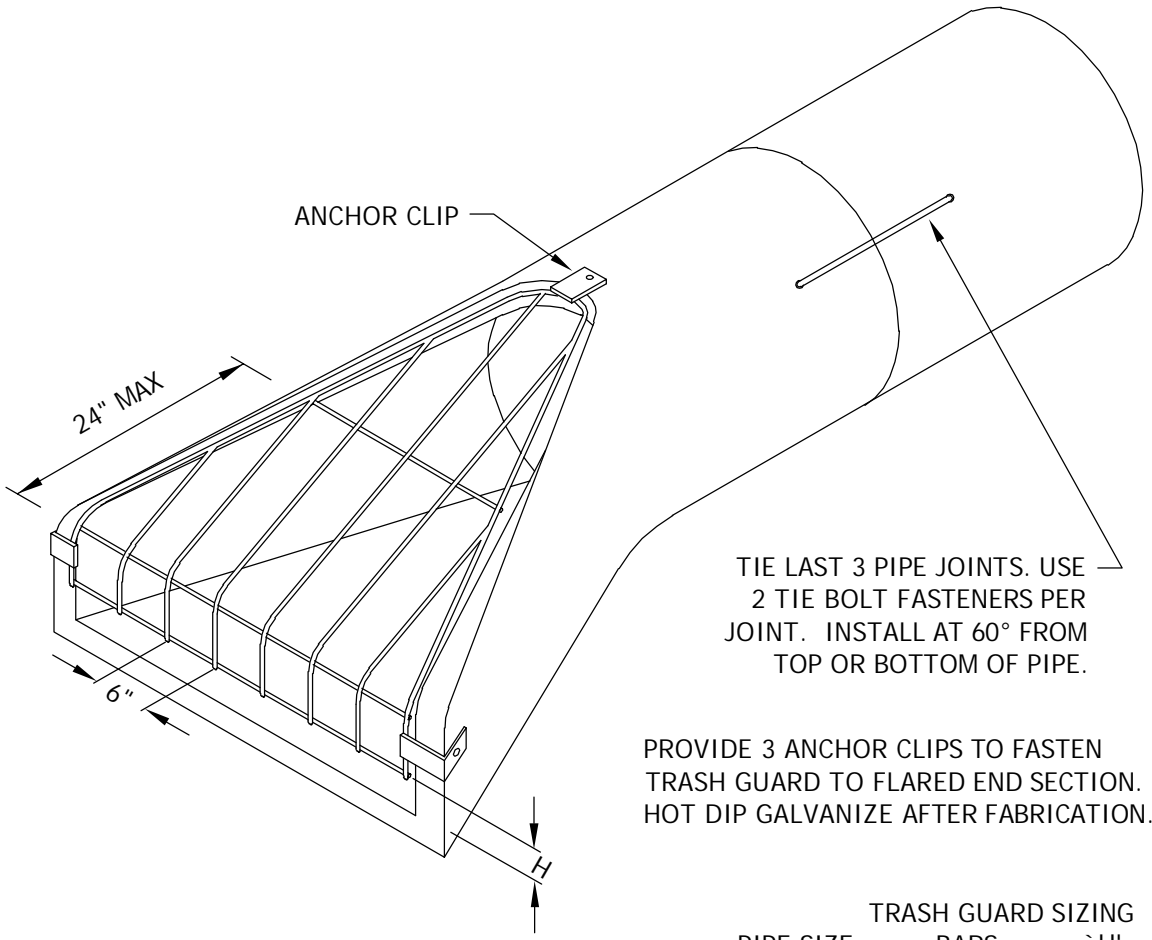

ISOMETRIC

TIE LAST 3 PIPE JOINTS. USE 2 TIE BOLT FASTENERS PER JOINT. INSTALL AT 60° FROM TOP OR BOTTOM OF PIPE.

PROVIDE 3 ANCHOR CLIPS TO FASTEN TRASH GUARD TO FLARED END SECTION. HOT DIP GALVANIZE AFTER FABRICATION.

PIPE SIZE	TRASH GUARD SIZING		BOLTS
	BARS	H'	
12"	3/4"Ø	2 1/2"	5/8"
15"	3/4"Ø	3"	5/8"
18"	3/4"Ø	4"	5/8"
21"-24"	1"Ø	4"	3/4"
27"-36"	1"Ø	5"	3/4"
42"	1"Ø	6"	3/4"
48"-54"	1 1/4"Ø	6"	1"
60"-72"	1 1/4"Ø	7"	1"
78"-90"	1 1/4"Ø	8"	1"

2335 Highway 36 W
 St. Paul, MN 55113
 www.stantec.com

**FLARED END SECTION
 AND TRASH GUARD**

CHASKA, MINNESOTA

LAST REVISION:
 MAY 2023

PLATE NO.
STO-10

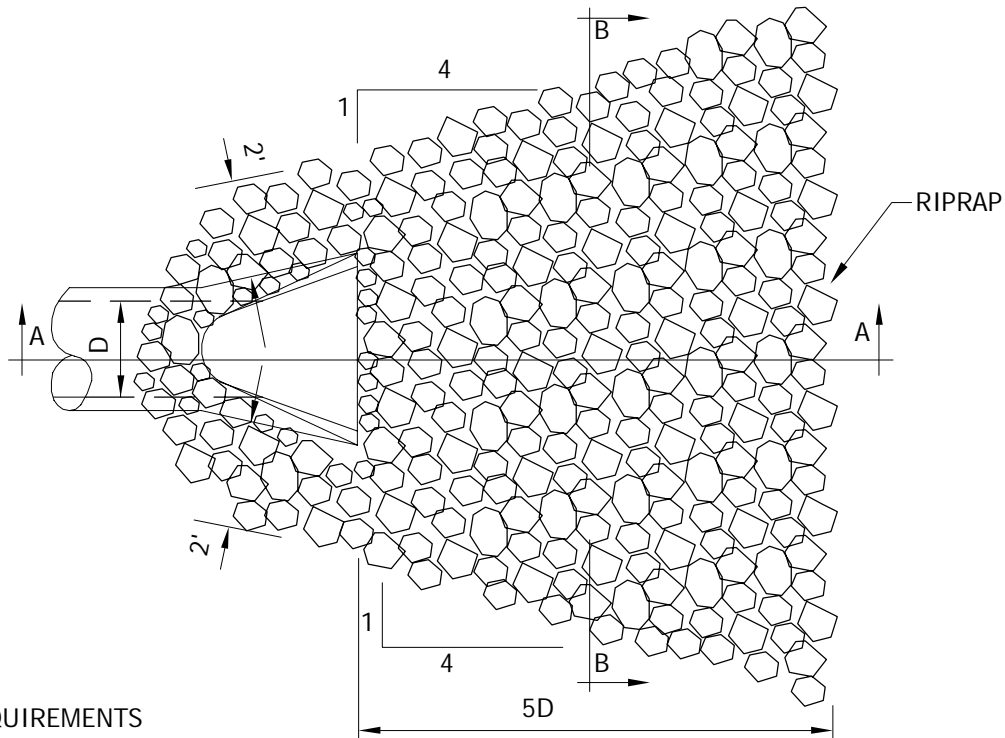

RIPRAP REQUIREMENTS

12" TO 18"	4 CUBIC YARDS CL.3
21" TO 27"	8 CUBIC YARDS CL.3
30" TO 36"	12 CUBIC YARDS CL.3
42" TO 48"	16 CUBIC YARDS CL.3
54" AND UP	20 CUBIC YARDS CL.4

PLAN

(ONE CUBIC YARD IS APPROXIMATELY 2,800 LBS.)

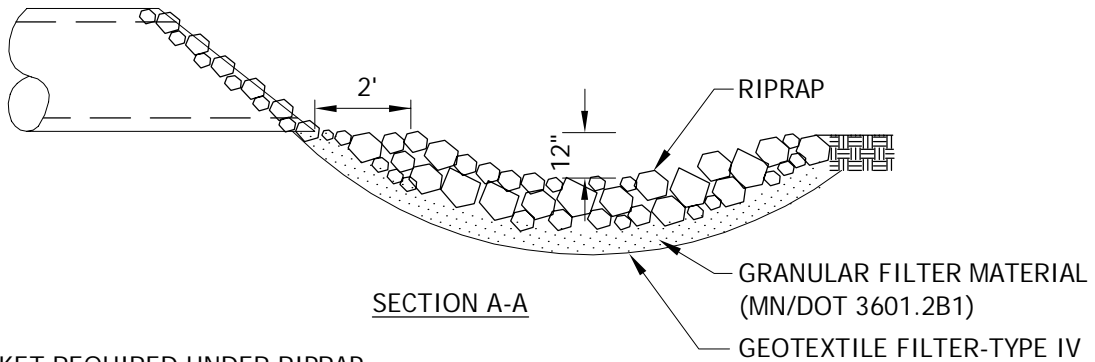

SECTION A-A

NOTE
 FILTER BLANKET REQUIRED UNDER RIPRAP
 OR 2 LAYERS OF 500X MIRAFI FABRIC OR
 EQUAL

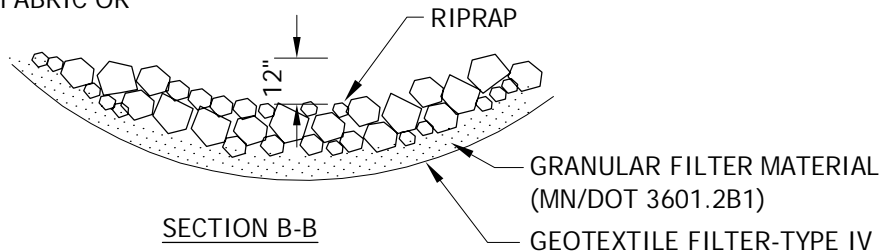

SECTION B-B



2335 Highway 36 W
 St. Paul, MN 55113
 www.stantec.com

RIPRAP AT OUTLETS
CHASKA, MINNESOTA

LAST REVISION:
 APRIL 2004

PLATE NO.
STO-11

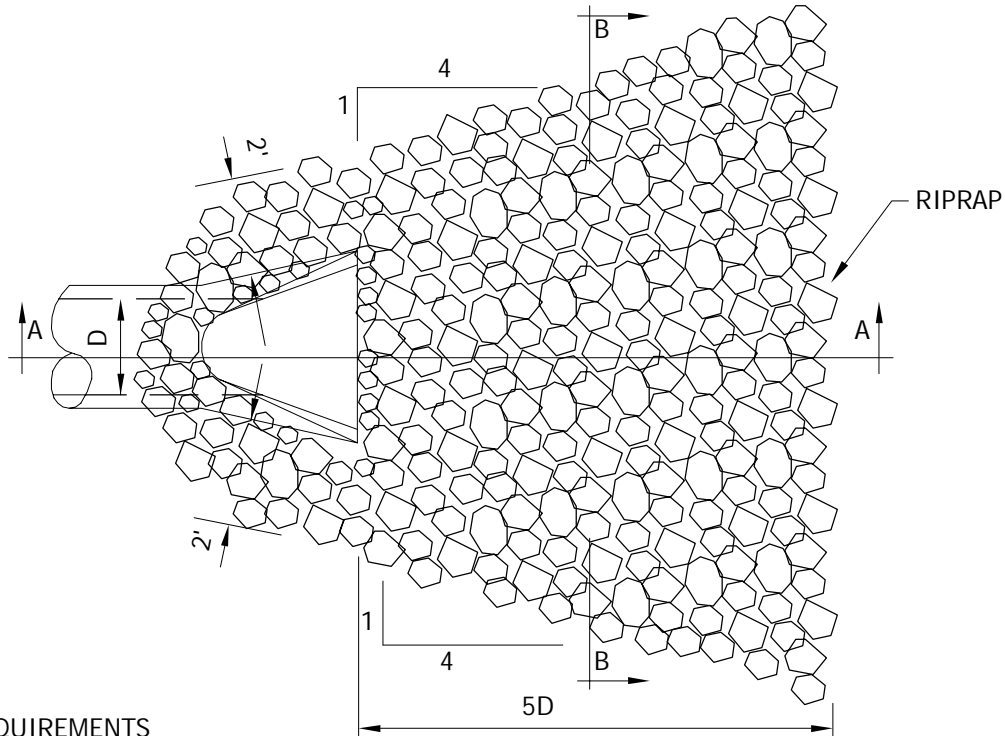

RIPRAP REQUIREMENTS

12" TO 18"	4 CUBIC YARDS CL.3
21" TO 27"	8 CUBIC YARDS CL.3
30" TO 36"	12 CUBIC YARDS CL.3
42" TO 48"	16 CUBIC YARDS CL.3
54" AND UP	20 CUBIC YARDS CL.4

PLAN

NOTE

FILTER BLANKET REQUIRED UNDER RIP RAP OR 2 LAYERS OF 500X MIRAFI FABRIC OR EQUAL

(ONE CUBIC YARD IS APPROXIMATELY 2,800 LBS.)

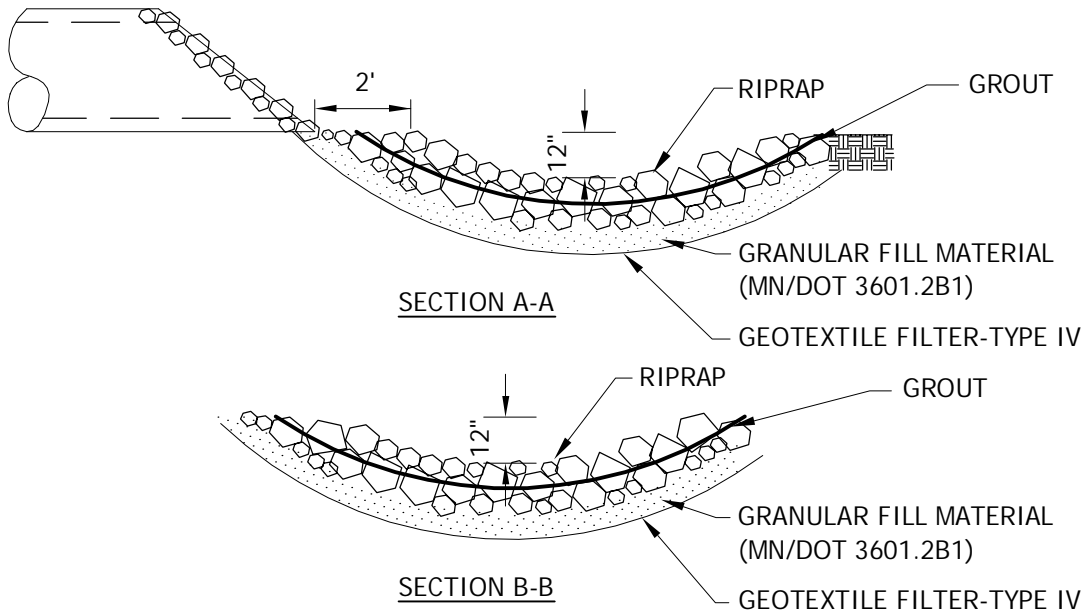

GROUTED RIPRAP AT OUTLETS

CHASKA, MINNESOTA

LAST REVISION:
APRIL 2004

PLATE NO.
STO-11B

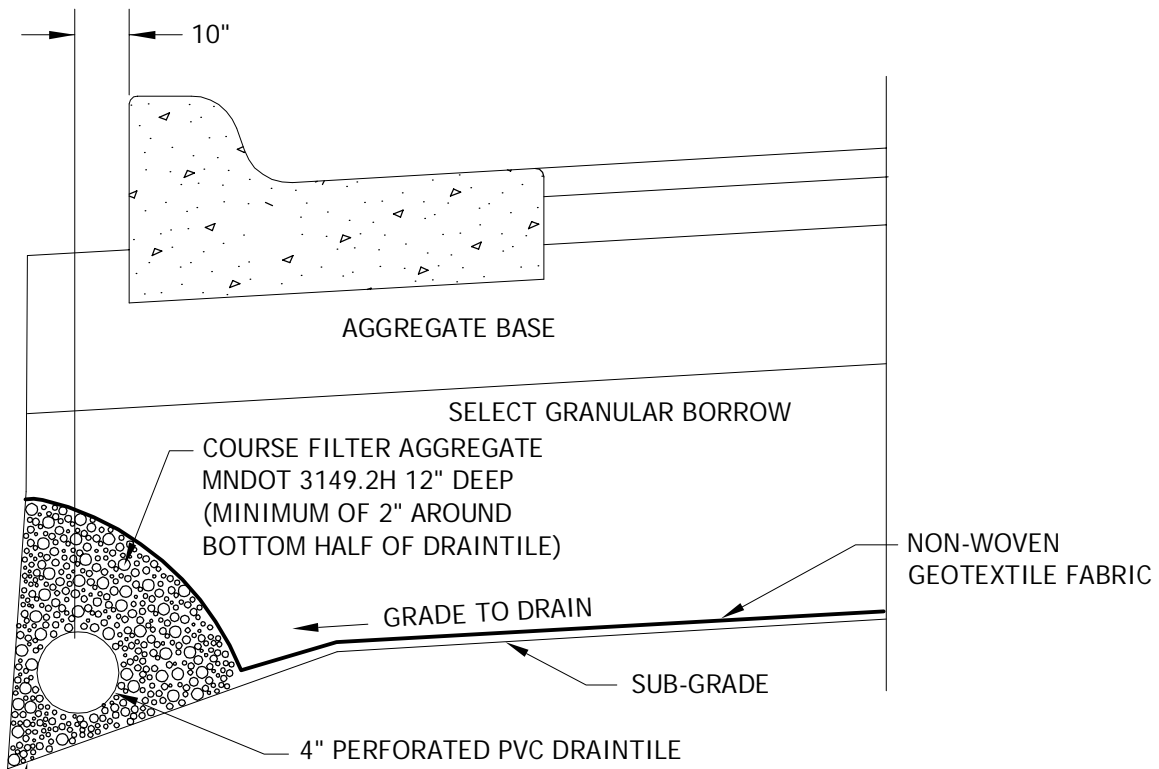

NOTCH CLAY SUB-GRADE
FOR PIPE PLACEMENT. TOP
OF PIPE MAX. 1" ABOVE
EDGE OF SUBGRADE.

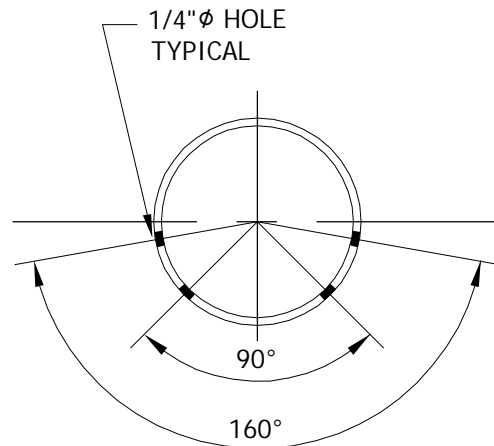

PVC PIPE DETAIL



2335 Highway 36 W
St. Paul, MN 55113
www.stantec.com

PERFORATED PVC DRAINTILE PIPE
BELOW CONCRETE CURB

CHASKA, MINNESOTA

LAST REVISION:
NOV. 2016

PLATE NO.
STO-12

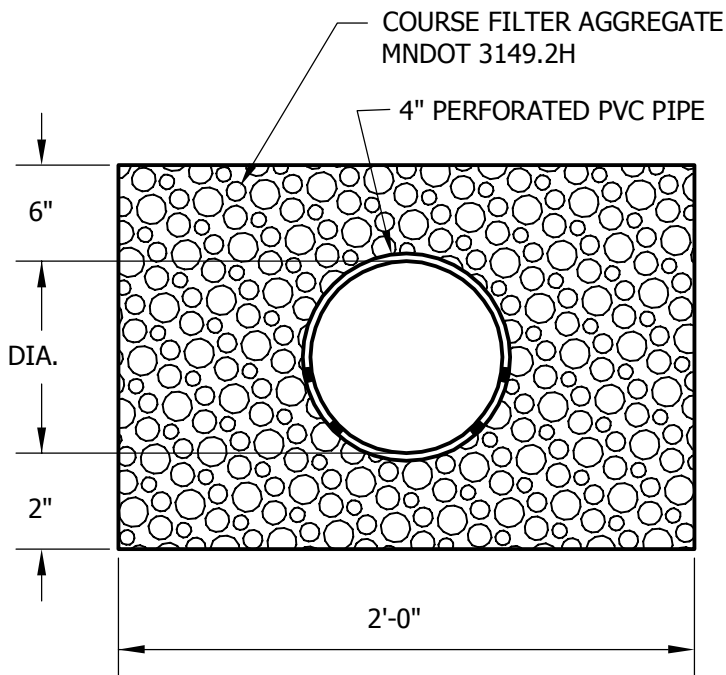

GEOTEXTILE WRAP SHALL BE ADDED
AT THE REQUEST OF THE OWNER.

PVC TRENCH DETAIL

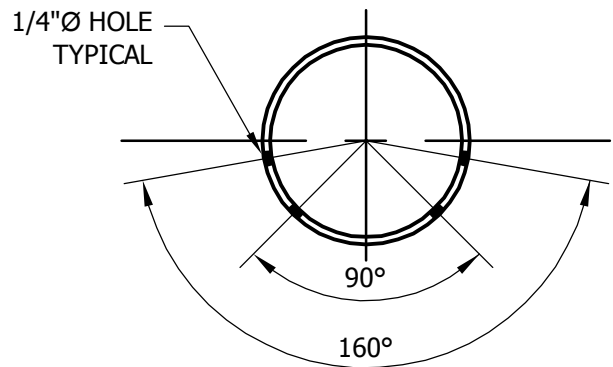

PVC PIPE DETAIL

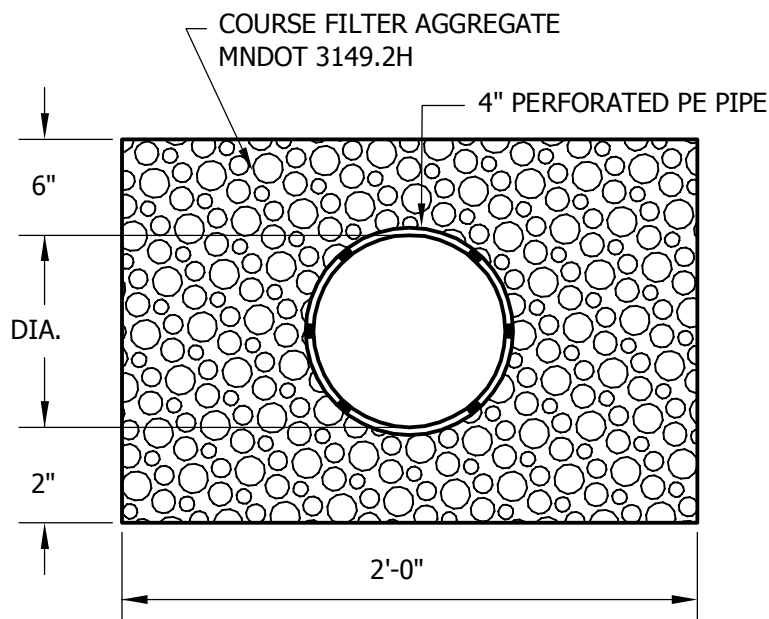

GEOTEXTILE WRAP SHALL BE ADDED
AT THE REQUEST OF THE OWNER.

P.E. TRENCH DETAIL



2335 Highway 36 W
St. Paul, MN 55113
www.stantec.com

PERFORATED PIPE TRENCH DETAIL

CHASKA, MINNESOTA

LAST REVISION:
NOV. 2014

PLATE NO.
STO-13

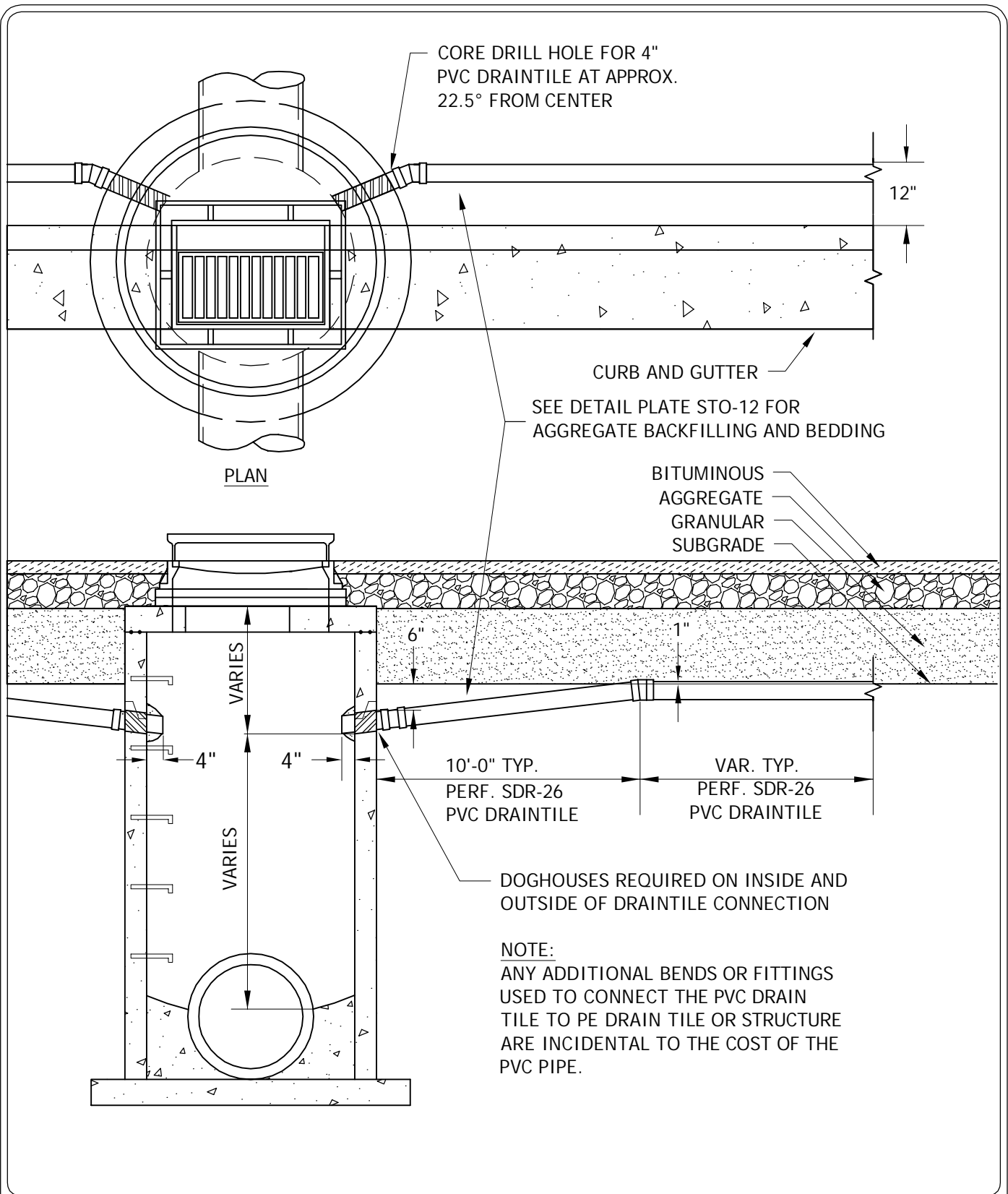

2335 Highway 36 W
 St. Paul, MN 55113
 www.stantec.com

DRAINTILE INSTALLATION INTO CATCHBASIN MANHOLE

CHASKA, MINNESOTA

LAST REVISION:
 APRIL 2016

PLATE NO.
 STO-14

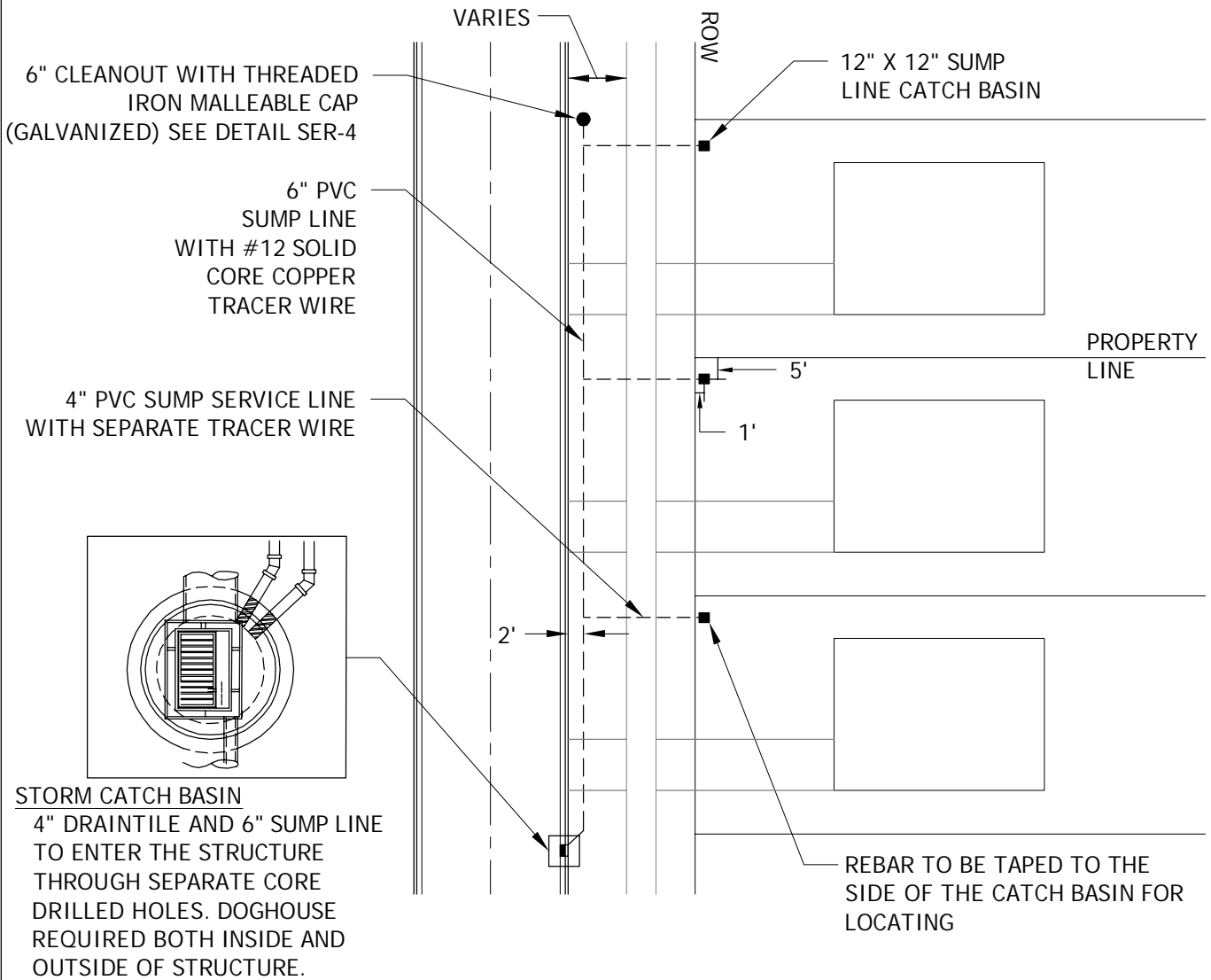

NOTES:

1. 6" PVC SUMP LINE TO BE INSTALLED 2' BELOW GRADE AND TO BE CORE DRILLED INTO NEAREST DOWNSTREAM CATCH BASIN.
2. EXTEND 4" PVC SUMP SERVICE FROM MAIN TO RIGHT OF WAY ON SUMP DISCHARGE SIDE OF BUILDING.
3. ALTERNATE CONFIGURATIONS ONLY WITH THE APPROVAL OF OWNER.
4. SEE ENGINEERING GUIDELINES OR SPECIFICATIONS FOR ADDITIONAL INFORMATION.
5. MAXIMUM SUMP LINE LENGTH 300'. IF LONGER SUMP LINE IS NECESSARY, INTERMEDIATE CLEANOUTS WILL BE REQUIRED EVERY 200'.
6. INSTALL 4" X 4" POST ADJACENT TO EACH SUMP CATCH BASIN FOR PROTECTION DURING CONSTRUCTION.
7. CLEAN OUT TO BE PLACED ON PROPERTY LINE AT END OF LAST SERVICE LINE. IF SERVICE FALLS IN DRIVEWAY THE MAINLINE WILL BE EXTENDED BEYOND DRIVEWAY/ALLEY TO ENSURE THE CLEANOUT IS IN GREEN SPACE.
8. A SEPARATE TRACER WIRE WILL EXTEND FROM THE FINISHED GRADE CLEANOUT LOCATION WITH TRACER WIRE BOX AND FOLLOW THE SUMP LINE TO THE STRUCTURE LOCATION.



733 Marquette Avenue, Suite 1000
 Minneapolis, MN 55402
 www.stantec.com

**PVC SUMP LINE
BEHIND CURB**

CHASKA, MINNESOTA

LAST REVISION:
 JUNE 2022

PLATE NO.
STO-15

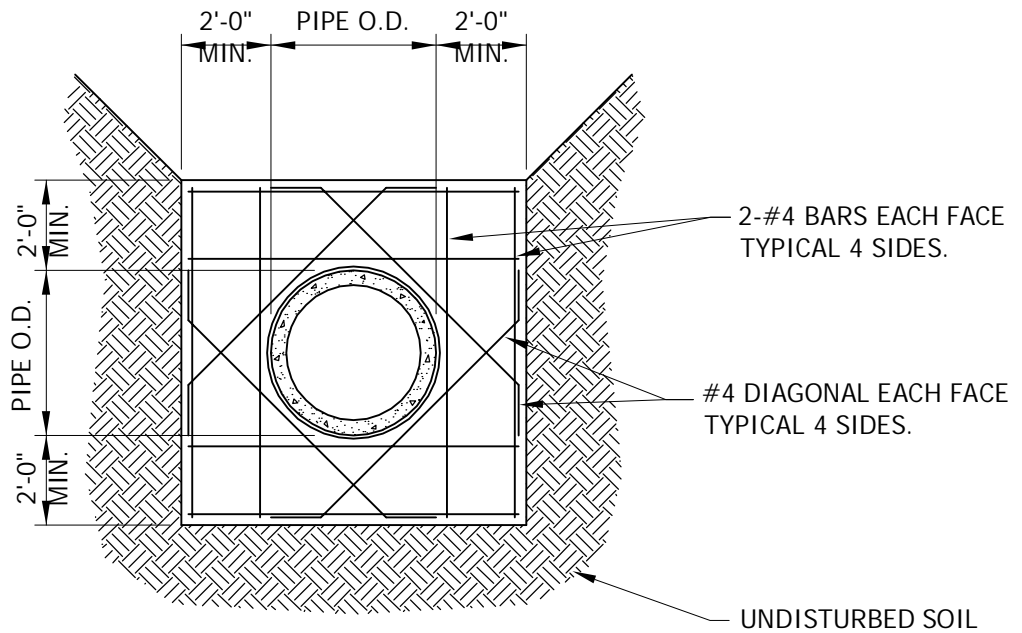

NOTE:
NO BLOCK OR OTHER
FILLER ALLOWED

SECTION AA

NOTE:
NOTCH ALL SIDES INTO
UNDISTURBED SOIL

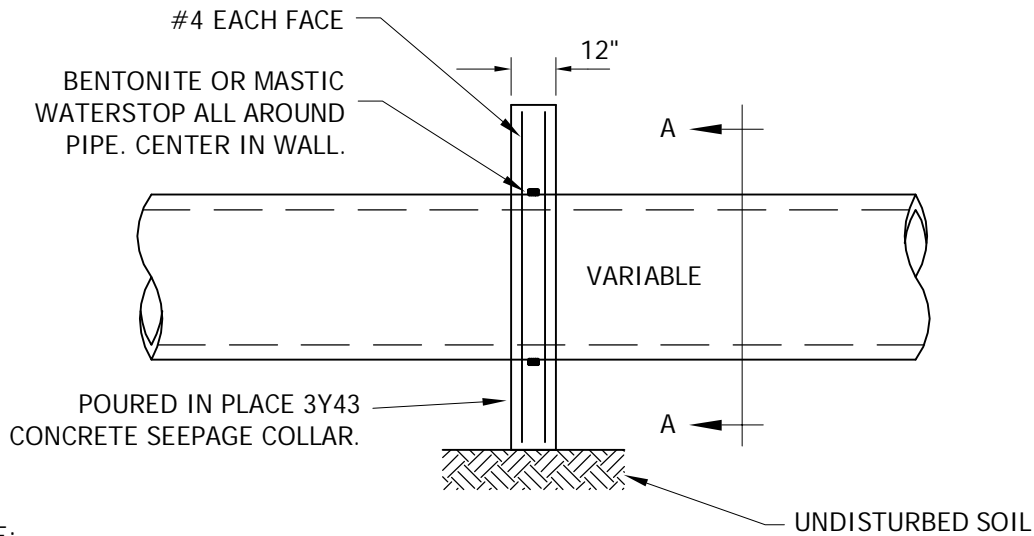

NOTE:
COLLAR MUST BE
ADEQUATELY FRAMED
USING WOOD OR OTHER
ACCEPLABLE MATERIAL



2335 Highway 36 W
St. Paul, MN 55113
www.stantec.com

SEEPAGE COLLAR
CHASKA, MINNESOTA

LAST REVISION:
MARCH 2001

PLATE NO.
STO-16

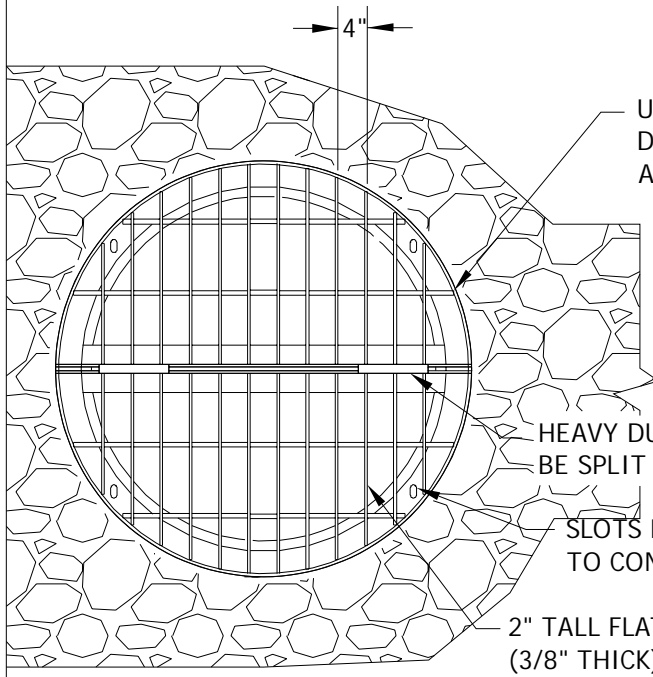

UNIT IS MADE FROM A36 STEEL AND IS HOT DIP GALVANIZED AFTER FABRICATION PER ASTM A123.

MH DIAMETER	SKIMMER OPENING
4'	3'X1.5'
5'	4'X1.5'
6'	5'X1.5'

HEAVY DUTY HINGES SO THAT GRATE CAN BE SPLIT INTO 2 PIECES

SLOTS FOR MOUNTING TO CONCRETE

2" TALL FLATS (3/8" THICK)

GRATE DETAIL

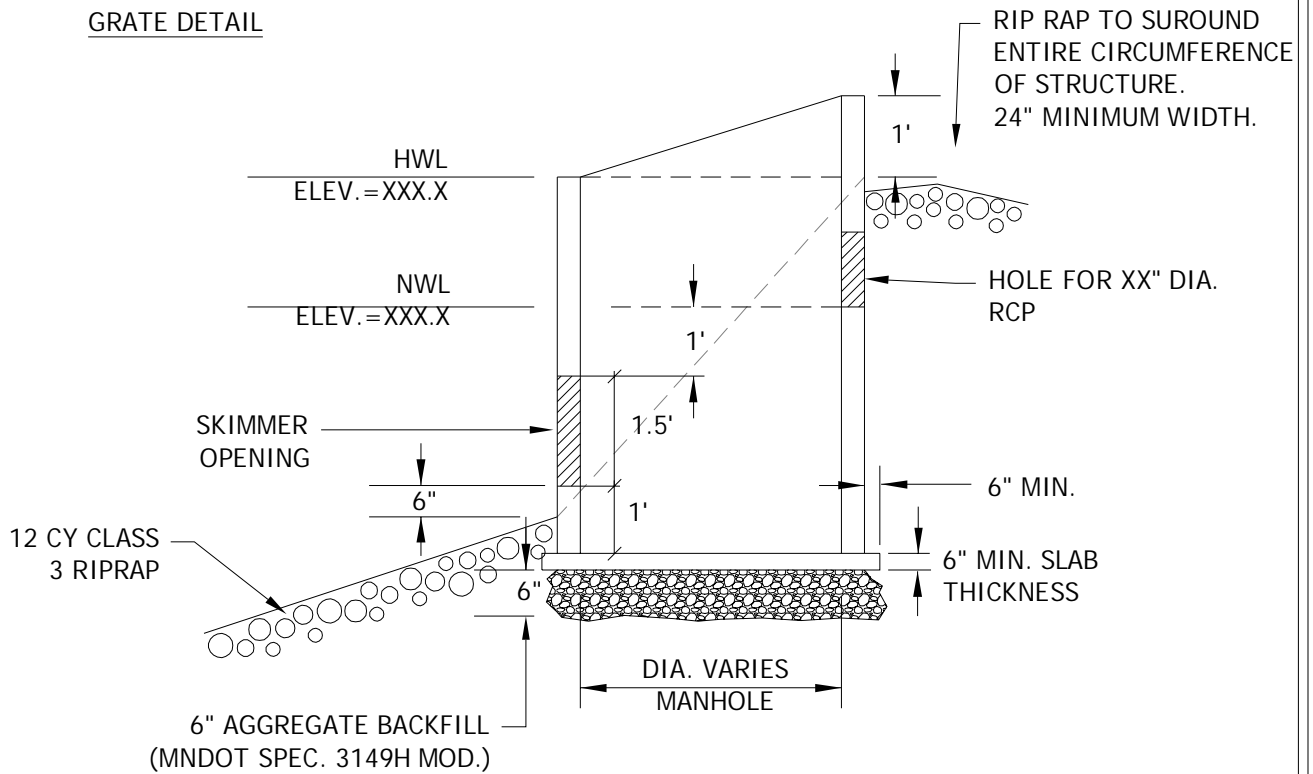

RIP RAP TO SUROUND ENTIRE CIRCUMFERENCE OF STRUCTURE. 24" MINIMUM WIDTH.

HOLE FOR XX" DIA. RCP

6" MIN.

6" MIN. SLAB THICKNESS

DIA. VARIES MANHOLE

6" AGGREGATE BACKFILL (MNDOT SPEC. 3149H MOD.)



2335 Highway 36 W
 St. Paul, MN 55113
 www.stantec.com

STANDARD SKIMMER STRUCTURE

CHASKA, MINNESOTA

LAST REVISION:
 JUNE 2018

PLATE NO.
STO-17

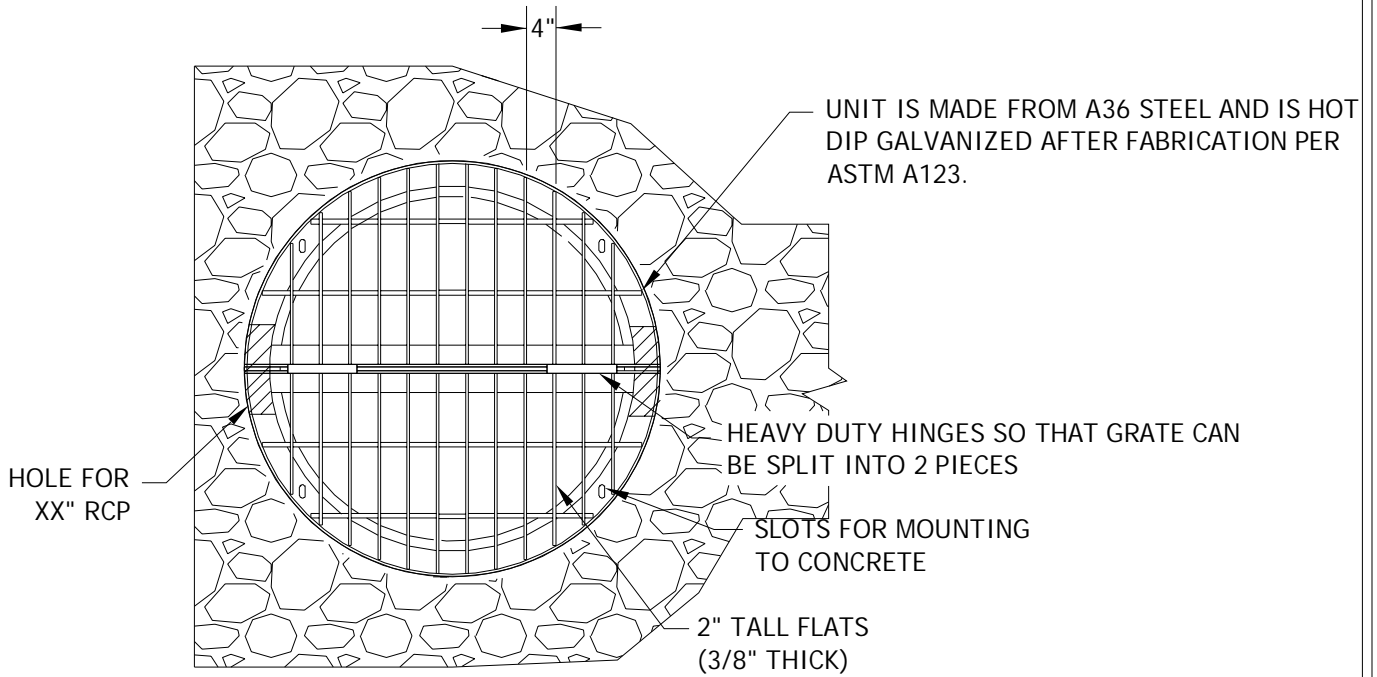

GRATE DETAIL

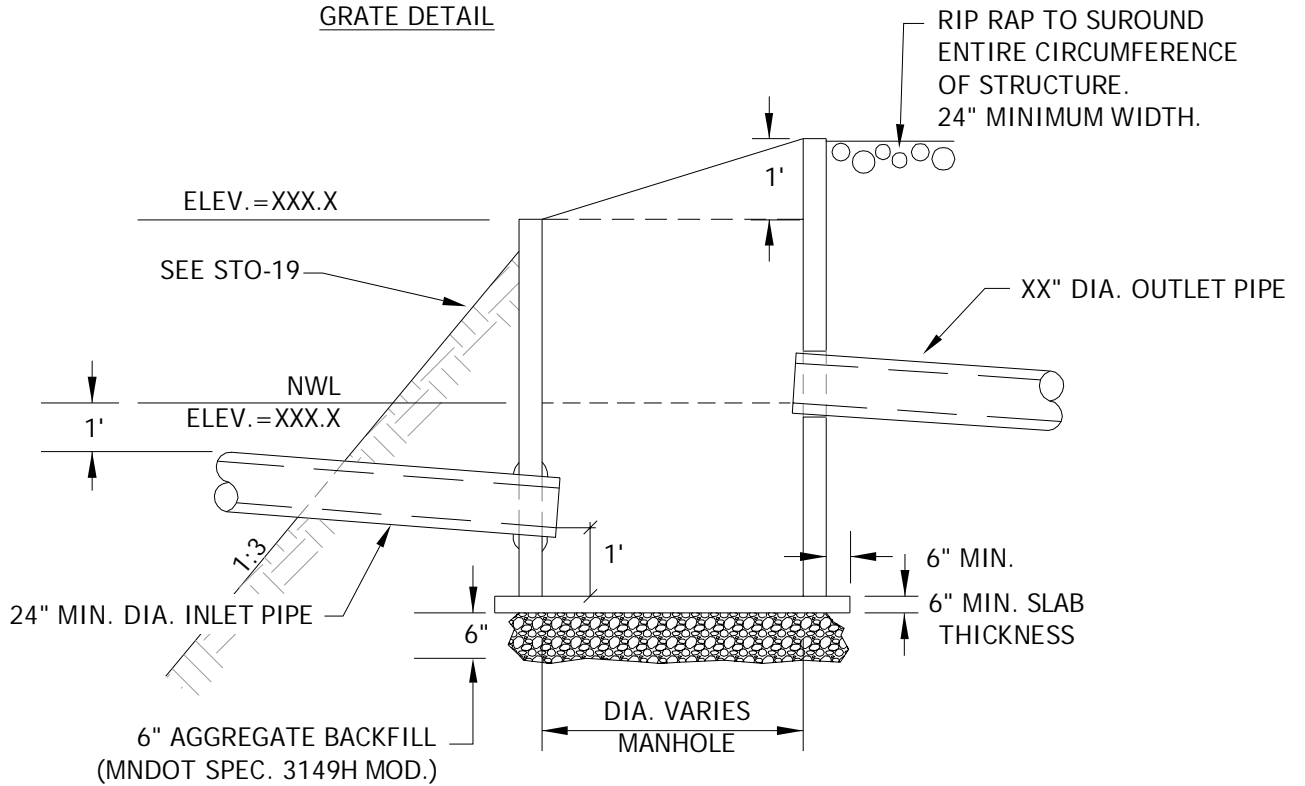

2335 Highway 36 W
 St. Paul, MN 55113
 www.stantec.com

**SKIMMER STRUCTURE WITH
 SUBMERGED PIPE**

CHASKA, MINNESOTA

LAST REVISION:
 JUNE 2023

PLATE NO.
 STO-17B

Plot Date: 05/25/2023
 Plotting Name: \\js0291\p05601\special\handdrawn\plate18.dwg
 User: js0291

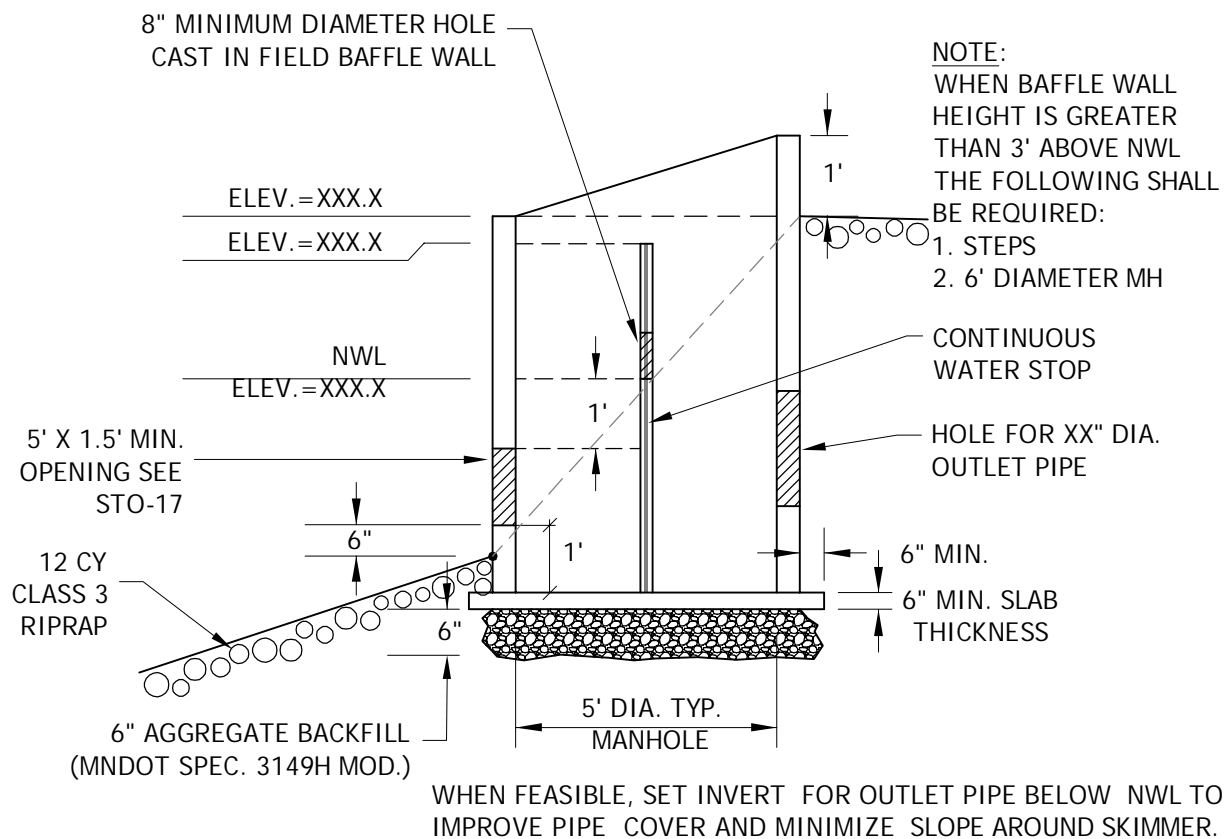
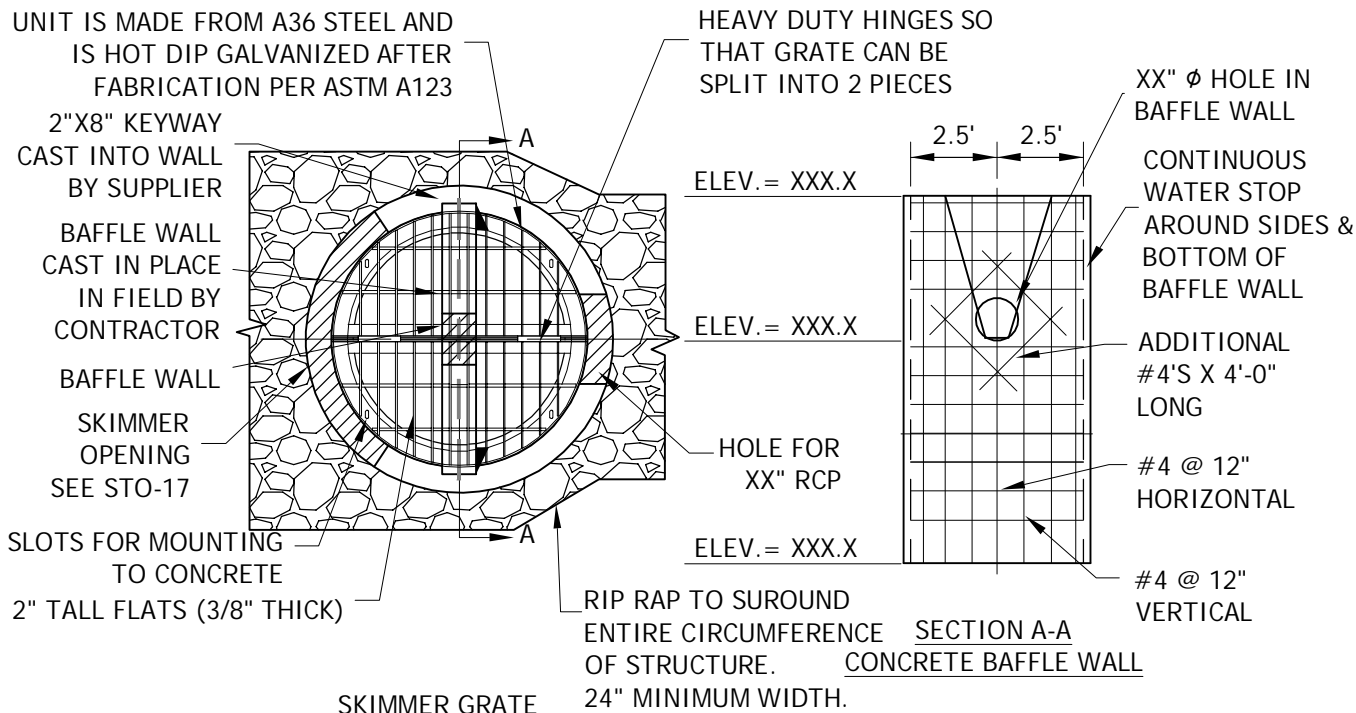

**SKIMMER STRUCTURE WITH
 CAST IN FIELD
 CONCRETE BAFFLE WALL WITH ORIFICE**

CHASKA, MINNESOTA

LAST REVISION:
 MAY 2023

PLATE NO.
STO-18

Plot Date: 03/07/2018
 Plotting Name: K:\chaska\plates\sto18.dwg
 Xref:

UNIT IS MADE FROM A36 STEEL AND IS HOT DIP GALVANIZED AFTER FABRICATION PER ASTM A123

HEAVY DUTY HINGES SO THAT GRATE CAN BE SPLIT INTO 2 PIECES

2"X8" KEYWAY CAST INTO WALL BY SUPPLIER

BAFFLE WALL CAST IN PLACE IN FIELD BY CONTRACTOR

BAFFLE WALL

SKIMMER OPENING SEE STO-17

SLOTS FOR MOUNTING TO CONCRETE
2" TALL FLATS (3/8" THICK)

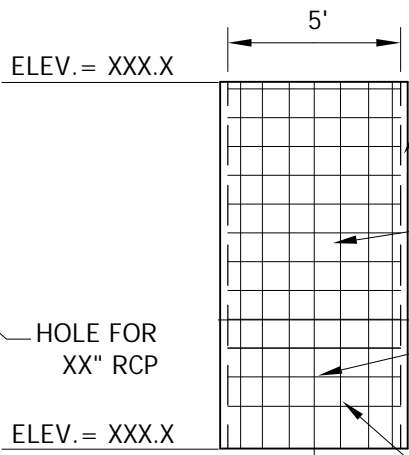
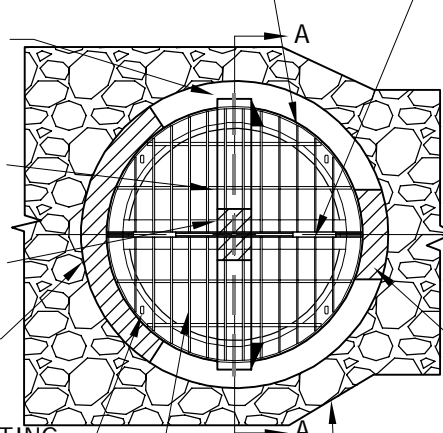

CONTINUOUS WATER STOP AROUND SIDES & BOTTOM OF BAFFLE WALL

ADDITIONAL #4'S X 4'-0" LONG

#4 @ 12" HORIZONTAL

#4 @ 12" VERTICAL

RIP RAP TO SURROUND ENTIRE CIRCUMFERENCE OF STRUCTURE. 24" MINIMUM WIDTH.

SKIMMER GRATE

NOTE:
WHEN BAFFLE WALL HEIGHT IS GREATER THAN 3' ABOVE NWL THE FOLLOWING SHALL BE REQUIRED:

1. STEPS
2. 6' DIAMETER MH

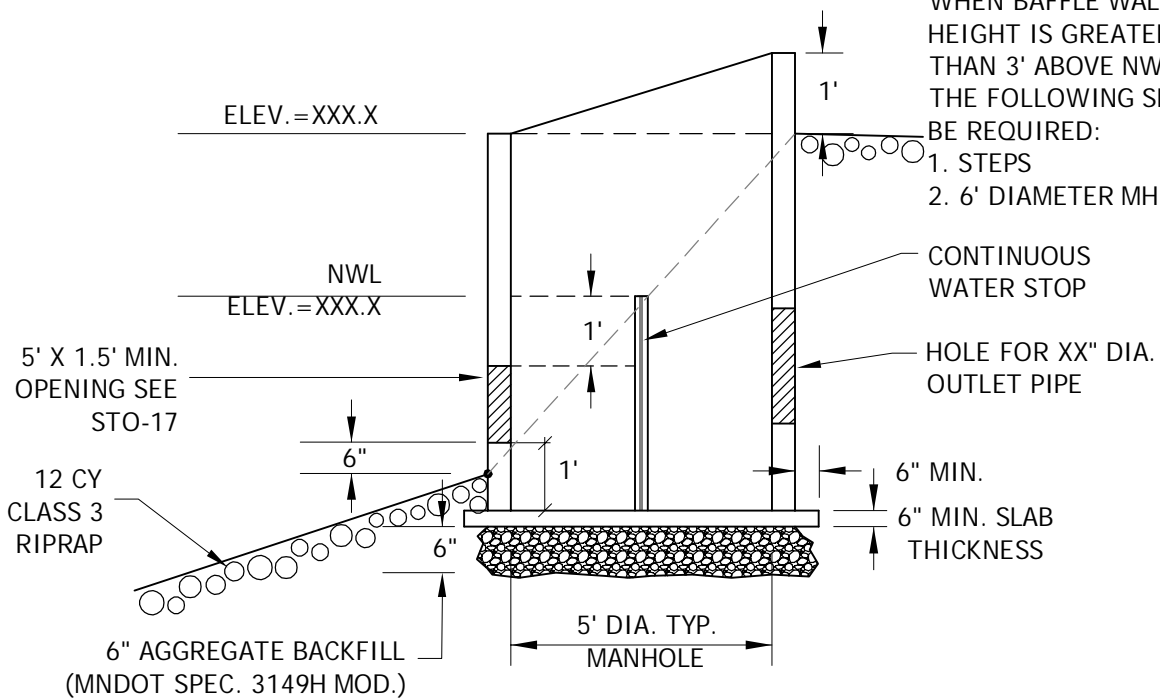

WHEN FEASIBLE, SET INVERT FOR OUTLET PIPE BELOW NWL TO IMPROVE PIPE COVER AND MINIMIZE SLOPE AROUND SKIMMER.



2335 Highway 36 W
St. Paul, MN 55113
www.stantec.com

SKIMMER STRUCTURE WITH
CAST IN FIELD
CONCRETE BAFFLE WALL

CHASKA, MINNESOTA

LAST REVISION:
MARCH 2018

PLATE NO.
STO-18B

Plot Date: 06/02/2023
 Plotting Name: R:\chaska\plates\sto-18c.dwg
 User: J.M.T.

UNIT IS MADE FROM A36 STEEL AND IS HOT DIP GALVANIZED AFTER FABRICATION PER ASTM A123

2"X8" KEYWAY CAST INTO WALL BY SUPPLIER

BAFFLE WALL CAST IN PLACE IN FIELD BY CONTRACTOR

BAFFLE WALL

HOLE FOR XX" RCP

SLOTS FOR MOUNTING TO CONCRETE
2" TALL FLATS (3/8" THICK)

SKIMMER GRATE

HEAVY DUTY HINGES SO THAT GRATE CAN BE SPLIT INTO 2 PIECES

ELEV. = XXX.X

ELEV. = XXX.X

HOLE FOR XX" RCP

ELEV. = XXX.X

RIP RAP TO SURROUND ENTIRE CIRCUMFERENCE OF STRUCTURE.
24" MINIMUM WIDTH.

2.5' 2.5'

XX" Ø HOLE IN BAFFLE WALL

CONTINUOUS WATER STOP AROUND SIDES & BOTTOM OF BAFFLE WALL

ADDITIONAL #4'S X 4'-0" LONG

#4 @ 12" HORIZONTAL

#4 @ 12" VERTICAL

SECTION A-A
CONCRETE BAFFLE WALL

NOTE:
WHEN BAFFLE WALL HEIGHT IS GREATER THAN 3' ABOVE NWL THE FOLLOWING SHALL BE REQUIRED:
1. STEPS
2. 6' DIAMETER MH

8" MINIMUM DIAMETER HOLE CAST IN FIELD BAFFLE WALL

ELEV. = XXX.X

SEE STO-19

NWL
ELEV. = XXX.X

1'

24" MIN. DIA. INLET PIPE

6" AGGREGATE BACKFILL (MNDOT SPEC. 3149H MOD.)



XX" DIA. OUTLET PIPE

ELEV. = XXX.X

CONTINUOUS WATER STOP

6" MIN.

6" MIN. SLAB THICKNESS

5' DIA. TYP. MANHOLE



2335 Highway 36 W
St. Paul, MN 55113
www.stantec.com

SKIMMER STRUCTURE WITH CAST IN FIELD CONCRETE BAFFLE WALL w/ ORIFICE AND SUBMERGED PIPE

CHASKA, MINNESOTA

LAST REVISION:
JUNE 2023

PLATE NO.
STO-18C

Plot Date: 05/11/2023
 Plotting name: \\s0291\ps0501\special\handdrawn\plate19.dwg
 User:

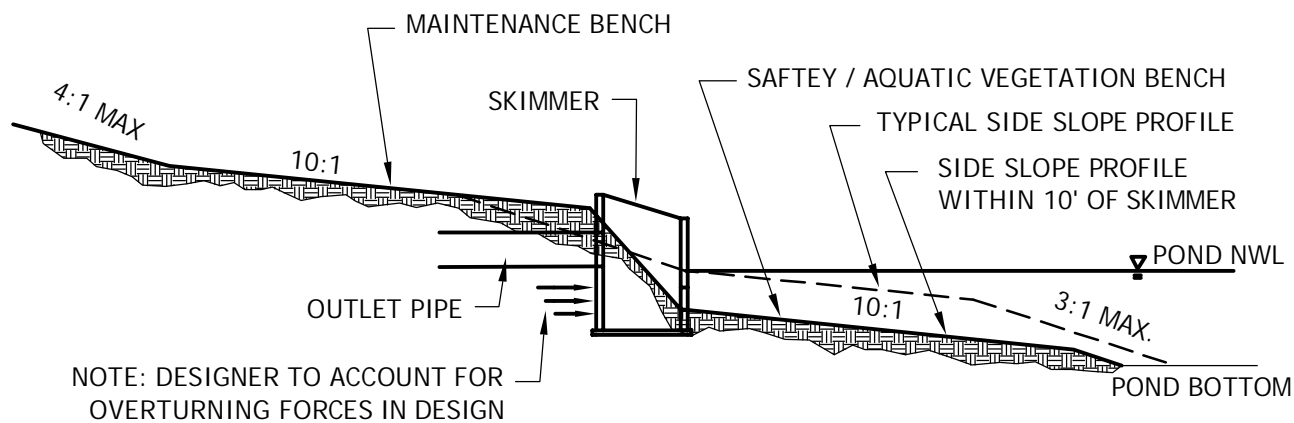

TYPICAL BENCH DETAIL WITHIN 10'
OF SKIMMER OUTLET

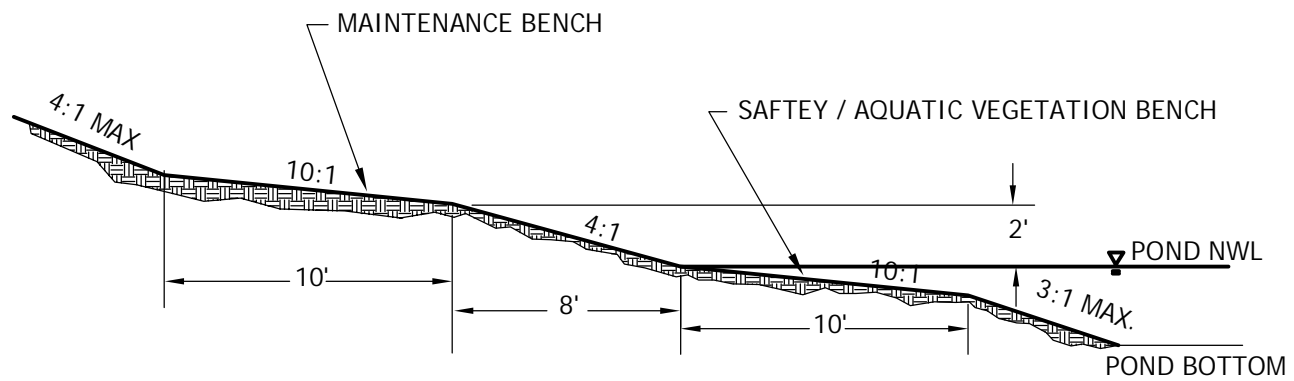

TYPICAL BENCH DETAIL

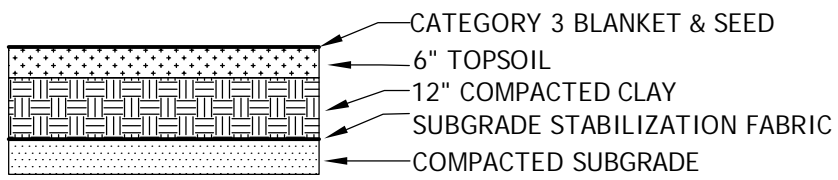

TYPICAL SECTION
MAINTENANCE BENCH



TYPICAL BENCH DETAIL
CHASKA, MINNESOTA

LAST REVISION:
MAY 2023

PLATE NO.
STO-19

CONCRETE MATERIALS AS FOLLOWS:

3F52 - MANUAL PLACEMENT

3F32 - SLIP FORM PLACEMENT

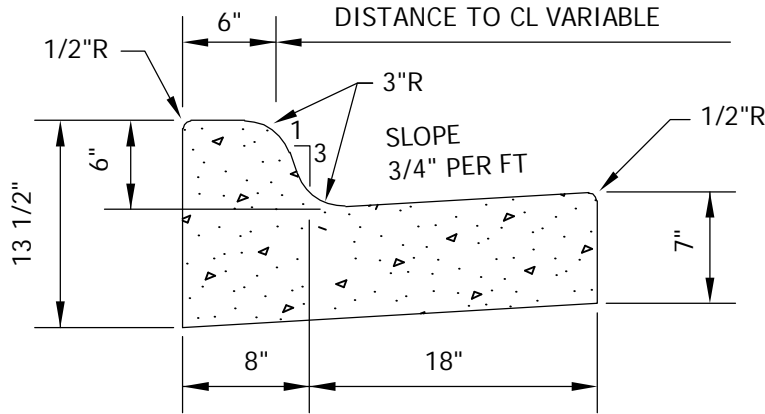

MNDOT B618

CURB REINFORCEMENT REQUIREMENTS:

2 - NO. 4 REINFORCING RODS, 20 FEET LONG, SHALL BE PLACED IN THE LOWER PORTION OF THE CURB CROSSING ALL SEWER AND WATER SERVICE TRENCHES, FIRE HYDRANT LEADS, STORM SEWER TRENCHES AND OTHER EXCAVATIONS OR TRENCHES. 2 - NO. 4 REINFORCING RODS SHALL ALSO BE PLACED ON EACH SIDE OF ALL CATCH BASINS LOCATED WITHIN THE CURB AND GUTTER.

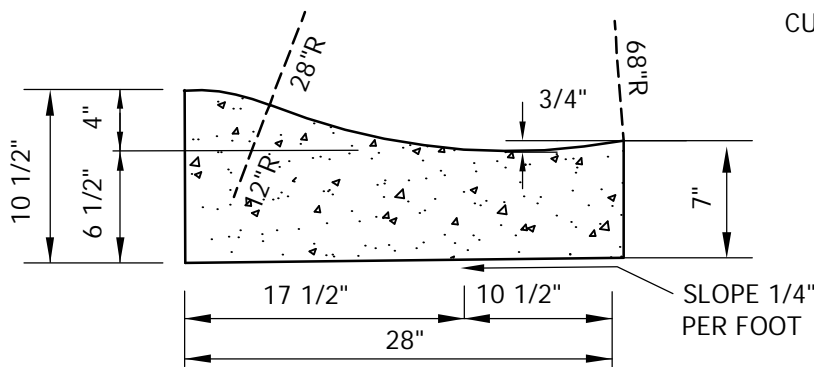

SURMOUNTABLE

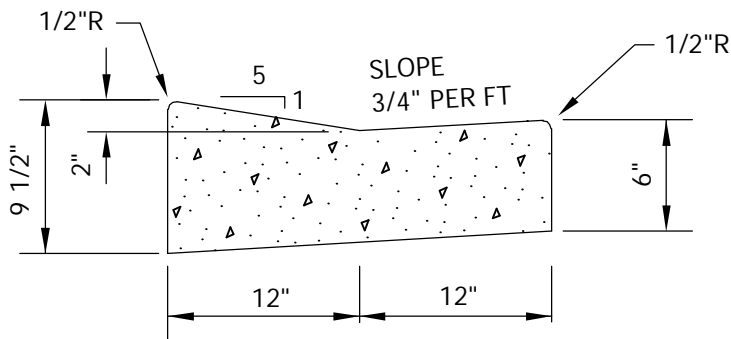

DRIVEWAY
SURMOUNTABLE



2335 Highway 36 W
 St. Paul, MN 55113
 www.stantec.com

CURB AND GUTTER
 CHASKA, MINNESOTA

LAST REVISION:
 APRIL 2023

PLATE NO.
 STR-1

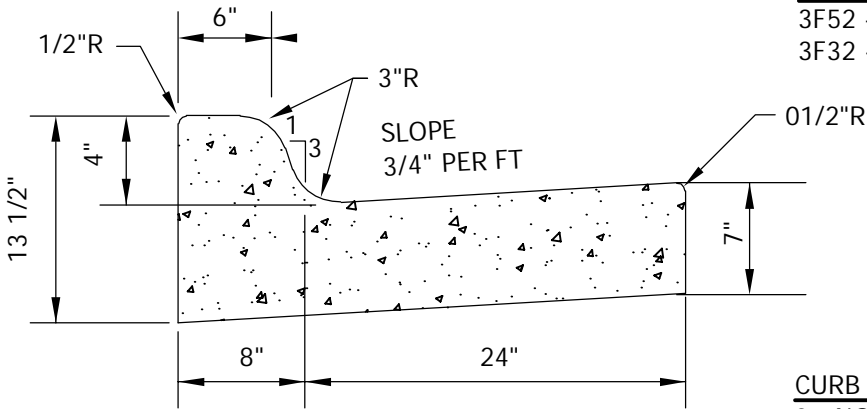

CONCRETE MATERIALS AS FOLLOWS:
 3F52 - MANUAL PLACEMENT
 3F32 - SLIP FORM PLACEMENT

MNDOT B424

CURB REINFORCEMENT REQUIREMENTS:
 2 - NO. 4 REINFORCING RODS, 20 FEET LONG, SHALL BE PLACED IN THE LOWER PORTION OF THE CURB CROSSING ALL SEWER AND WATER SERVICE TRENCHES, FIRE HYDRANT LEADS, STORM SEWER TRENCHES AND OTHER EXCAVATIONS OR TRENCHES. 2 - NO. 4 REINFORCING RODS SHALL ALSO BE PLACED ON EACH SIDE OF ALL CATCH BASINS LOCATED WITHIN THE CURB AND GUTTER.

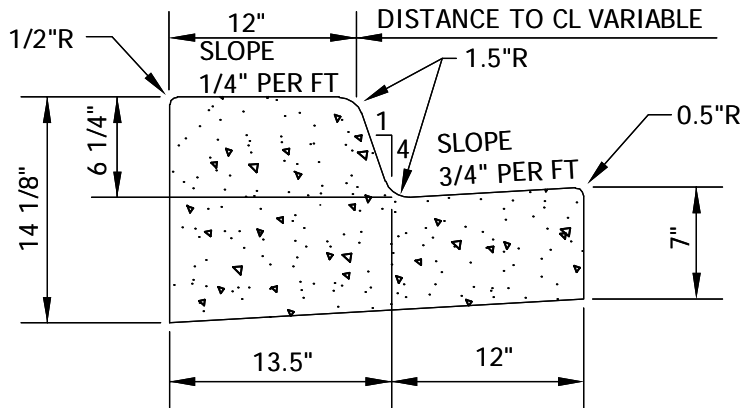

B612
 MODIFIED
 PARKBOARD

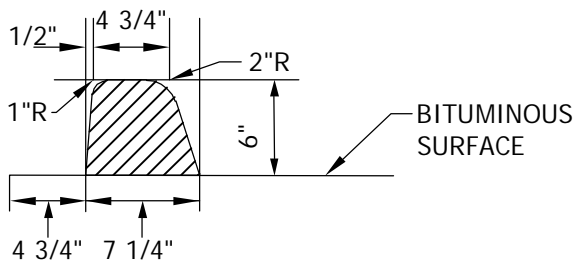

TYPE "D"
 STANDARD SECTION
 6" MACHINE LAID CURB



2335 Highway 36 W
 St. Paul, MN 55113
 www.stantec.com

NON STANDARD CURB AND GUTTER

CHASKA, MINNESOTA

LAST REVISION:
 APRIL 2023

PLATE NO.
 STR-1A

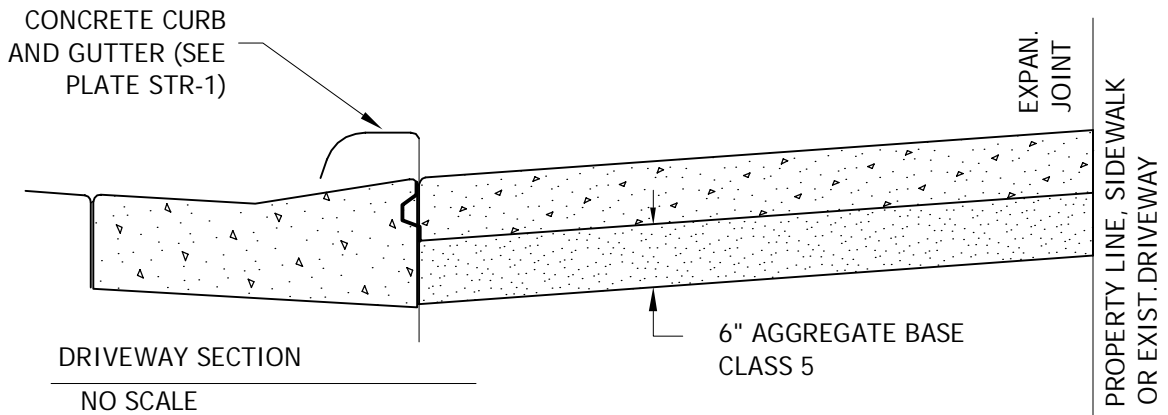

1. PANEL WIDTH SHALL NOT EXCEED 8' FEET WITHOUT A CONTRACTION JOINT.
2. DRIVEWAY TO BE ONE COURSE CONCRETE PAVEMENT.
3. 6" THICK FOR RESIDENTIAL DRIVE, 8" THICK FOR COMMERCIAL DRIVE AND ALLEY OR SPECIFIED.
4. KEYWAY TO BE INSTALLED ON NEW CURB TO DRIVEWAY CONSTRUCTION. NO.4 DOWEL BARS 1 FT. LONG SPACED 2 FT. O.C. MAY BE SUBSTITUTED FOR KEYWAY.
5. MAXIMUM DRIVEWAY WIDTH = 24'.
6. MINIMUM DISTANCE FROM LOT LINE = 5'.
7. CASTING REQUIRED ON CURBSTOPS LOCATED IN DRIVEWAYS.

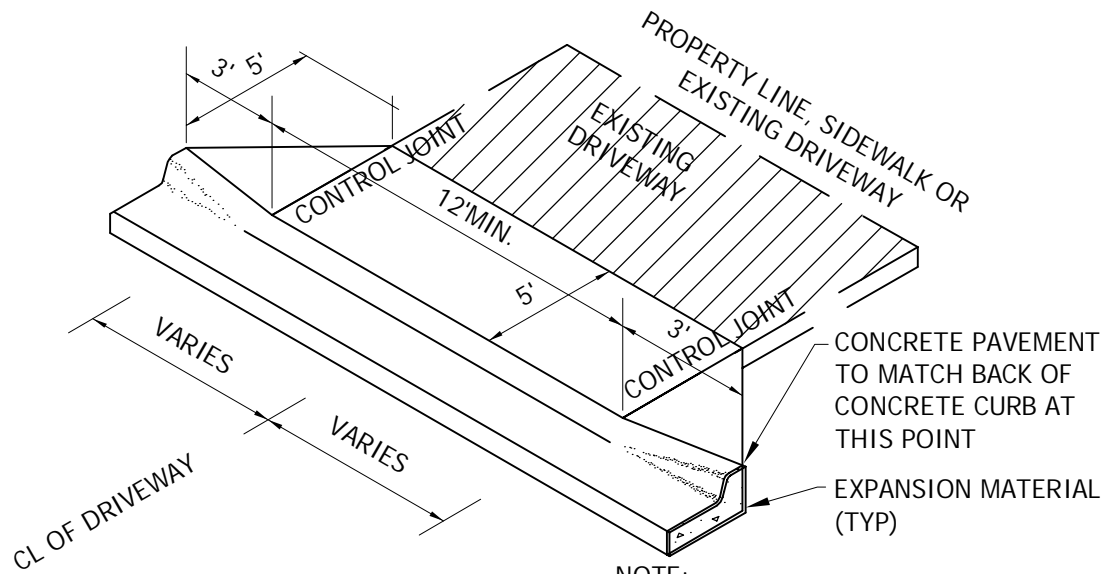
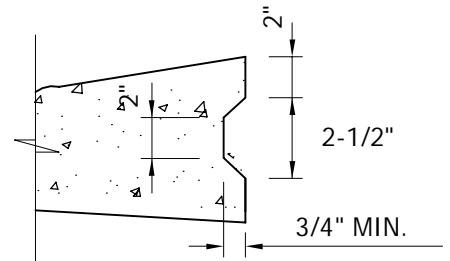

NOTE:
 CONTROL JOINTS IN CONCRETE CURB NOT TO EXCEED 8' SPACING THROUGH DRIVEWAY SECTION.



2335 Highway 36 W
 St. Paul, MN 55113
 www.stantec.com

CONCRETE DRIVEWAY APRON

CHASKA, MINNESOTA

LAST REVISION:
 APRIL 2016

PLATE NO.
 STR-2

Plot Date: 04/07/2016
Drawing name: R:\cadd\del\plates\022016\Detail Plates\STR-3.DWG
User:

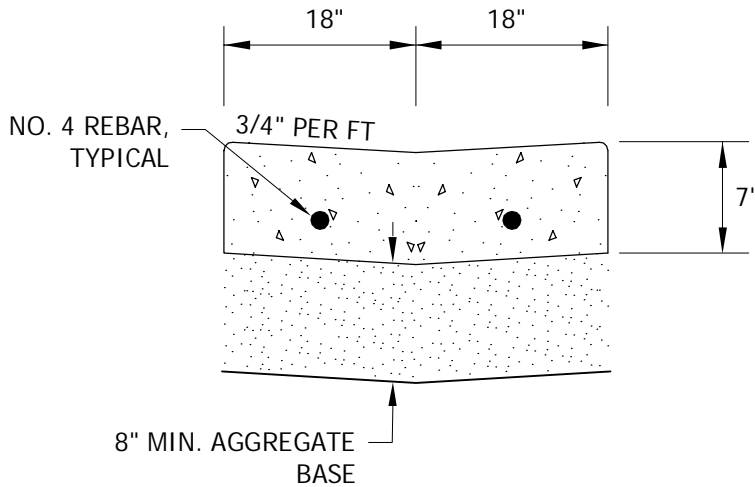
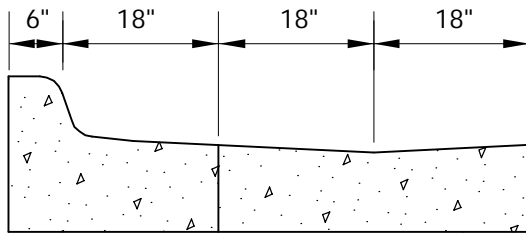
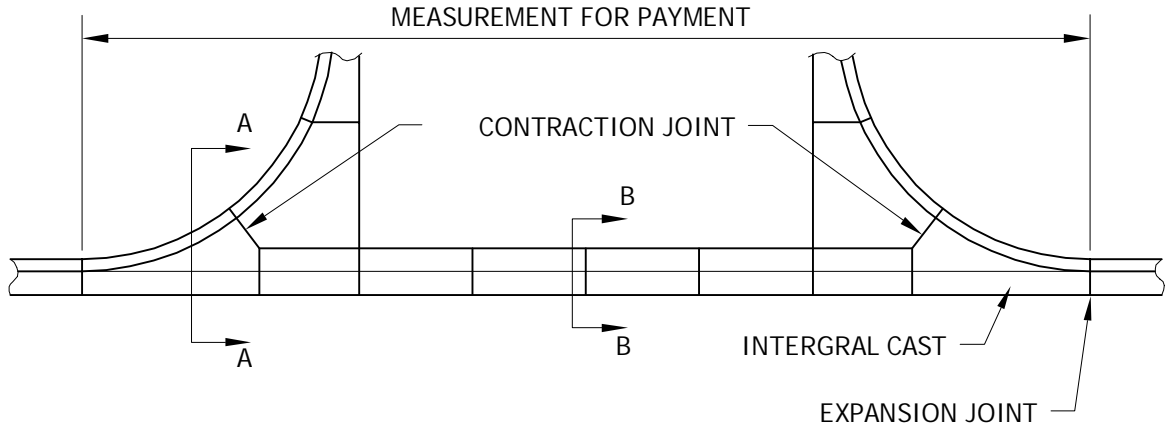

2335 Highway 36 W
St. Paul, MN 55113
www.stantec.com

COMMERCIAL DRIVEWAY

CHASKA, MINNESOTA

LAST REVISION:
APRIL 2016

PLATE NO.
STR-3

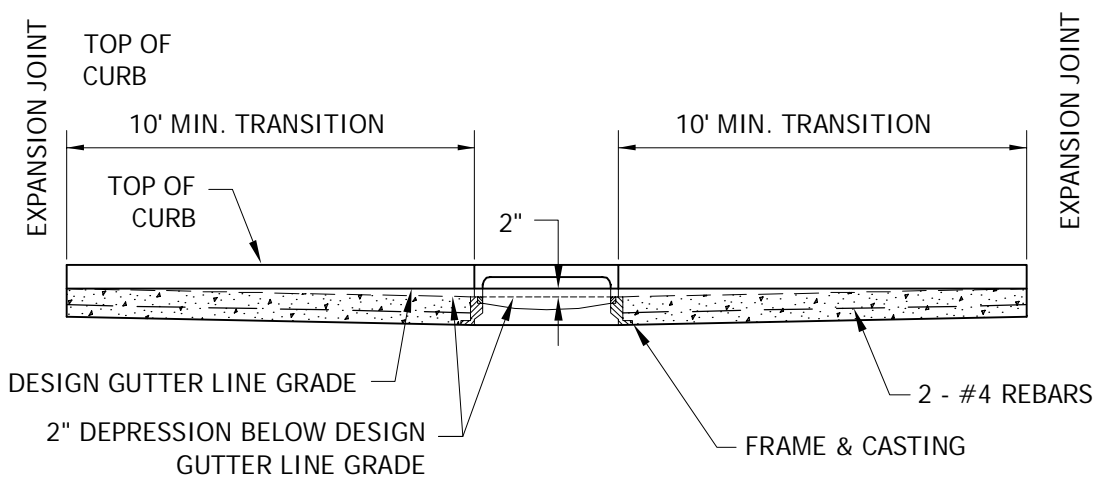
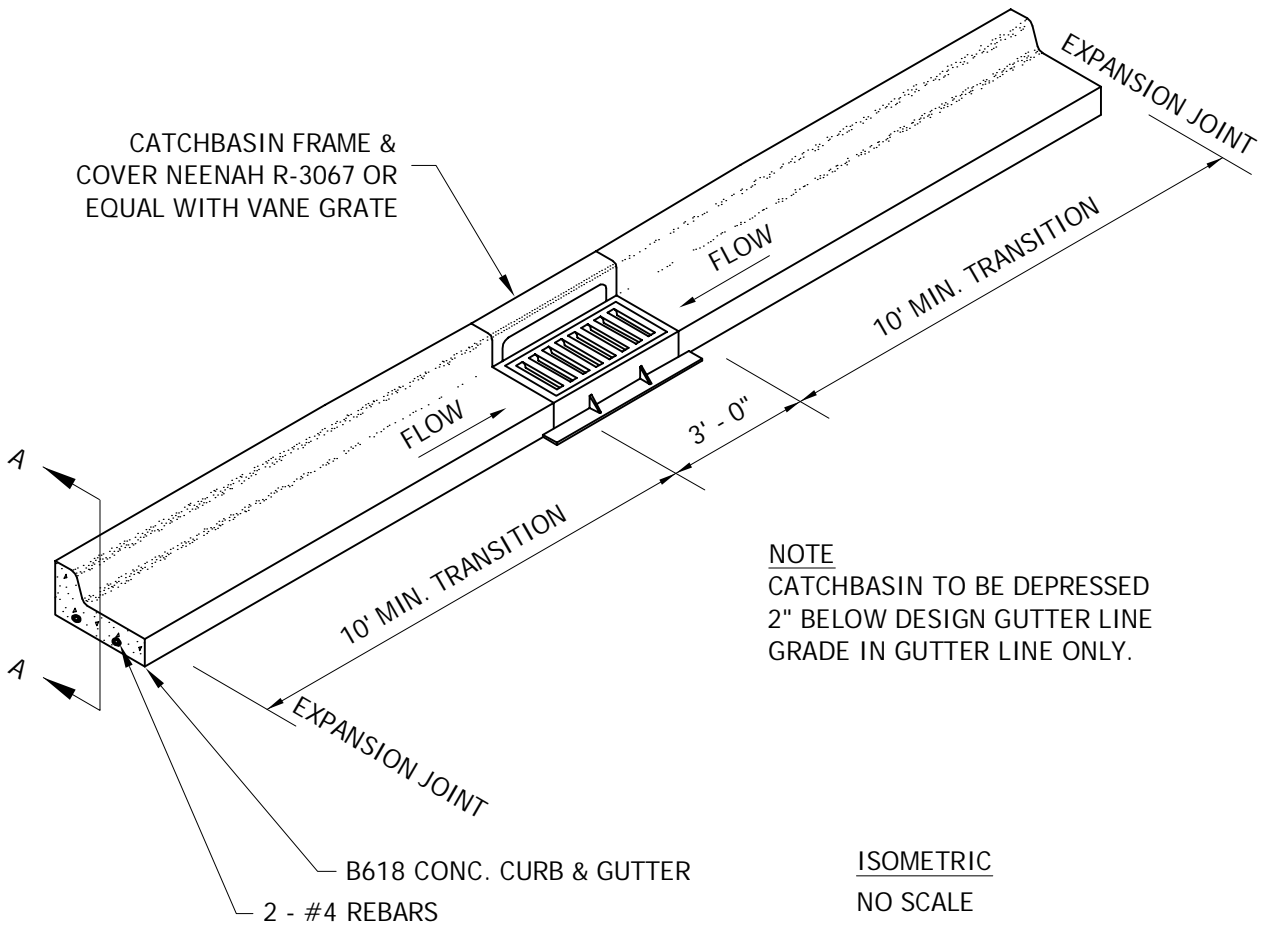

SECTION A-A
 NO SCALE



B618 CURB & GUTTER
 CONSTRUCTION AT CATCHBASIN

CHASKA, MINNESOTA

LAST REVISION:
 MARCH 2008

PLATE NO.
 STR-4

NOTE:
 SURMOUNTABLE CURB & GUTTER TO BE FORMED
 INTO A B618 TYPE AT CATCHBASIN.

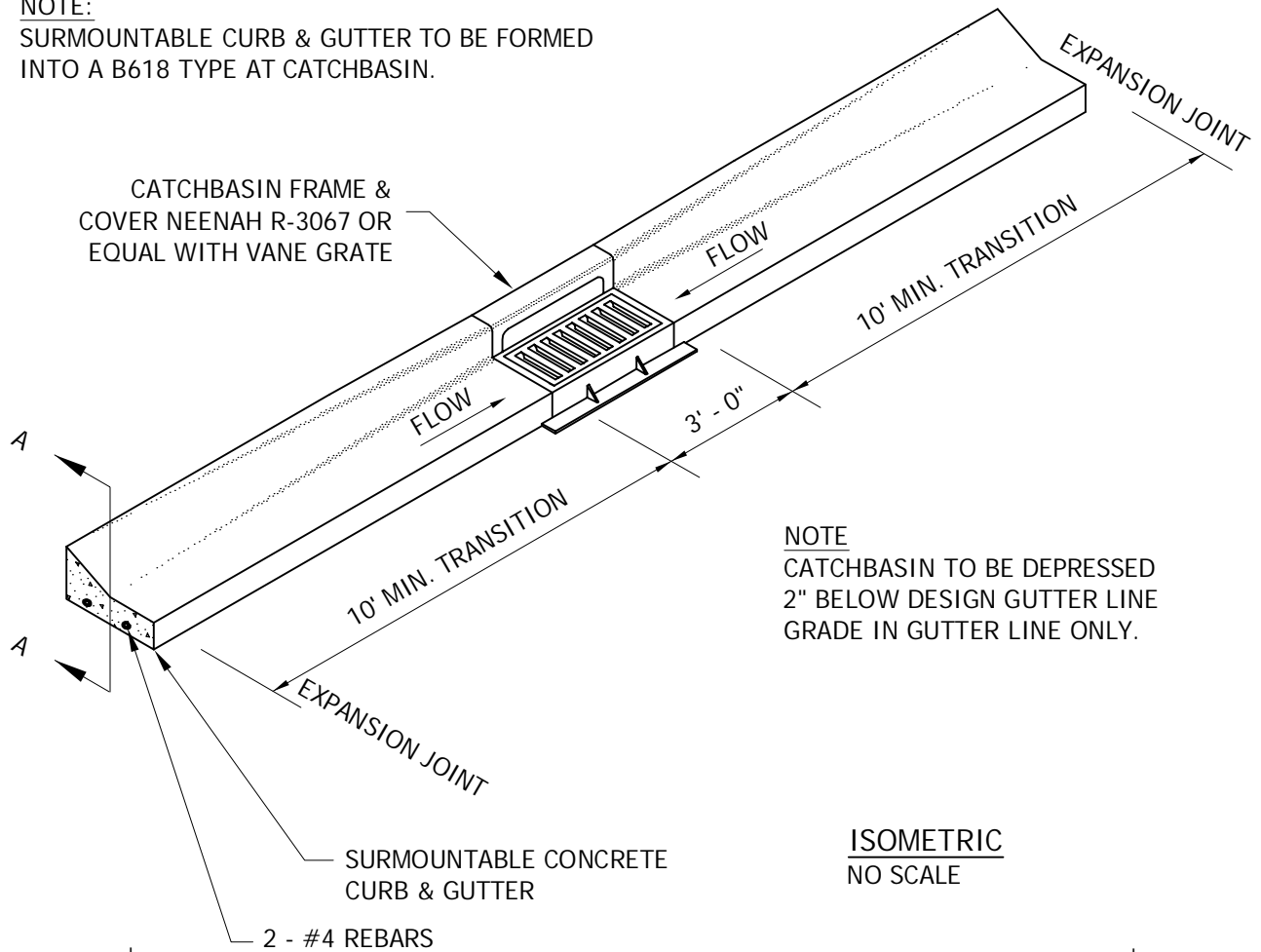

NOTE
 CATCHBASIN TO BE DEPRESSED
 2" BELOW DESIGN GUTTER LINE
 GRADE IN GUTTER LINE ONLY.

ISOMETRIC
 NO SCALE

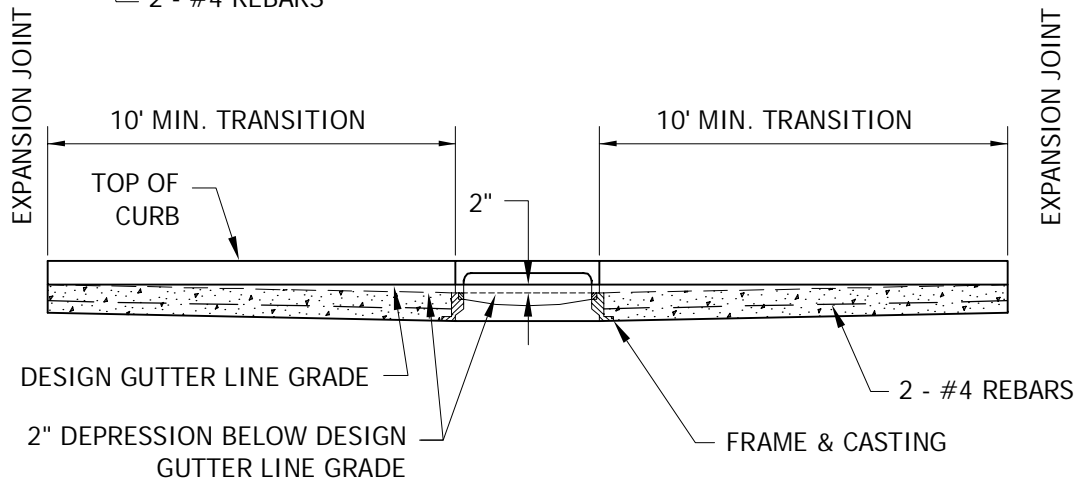

SECTION A-A
 NO SCALE



2335 Highway 36 W
 St. Paul, MN 55113
 www.stantec.com

**SURMOUNTABLE CURB & GUTTER
 CONSTRUCTION AT CATCHBASIN**

CHASKA, MINNESOTA

LAST REVISION:
 MARCH 2008

PLATE NO.
STR-5

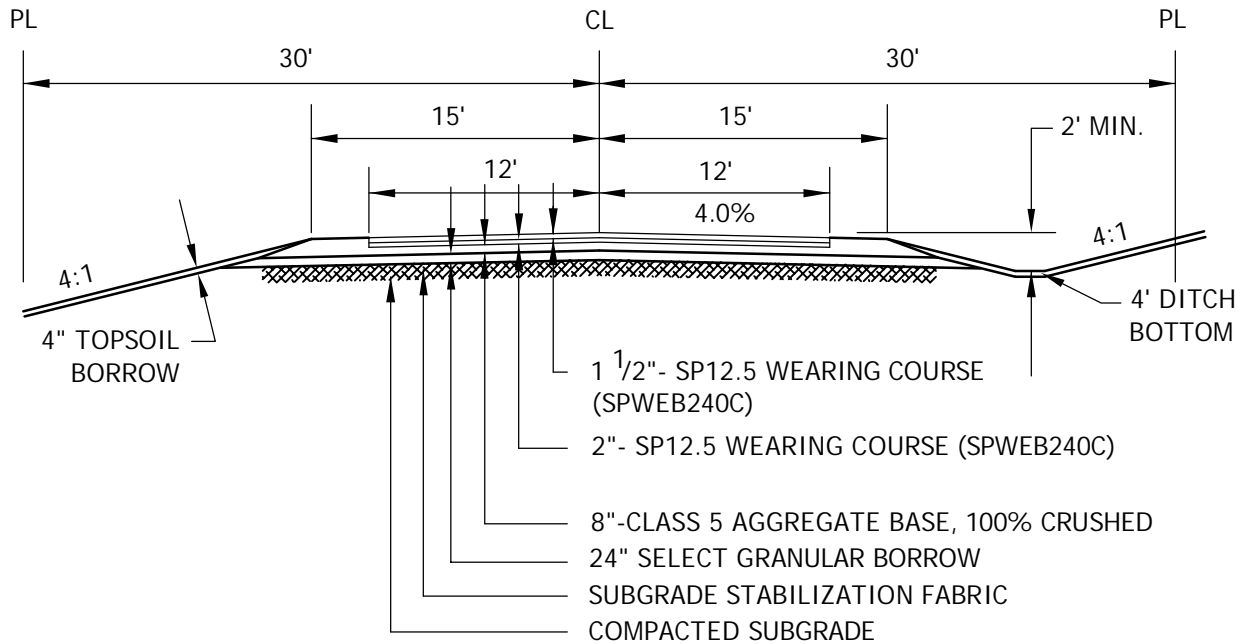

RURAL STREET SECTION

NOTES:

1. ALL ORGANIC OR OTHER UNSUITABLE MATERIALS SHALL BE REMOVED FROM BENEATH THE ROADWAY.
2. A TEST ROLL OF THE PREPARED SUBGRADE SHALL BE PERFORMED BY THE OWNER IN THE PRESENCE OF A CITY INSPECTOR. THE CITY HAS THE AUTHORITY TO REQUIRE ADDITIONAL SUBGRADE CORRECTION OR ELIMINATE THE STABILIZATION FABRIC.
3. THE CITY RESERVES THE RIGHT TO MODIFY STREET SECTION AS REQUIRED.
4. NO CONCRETE WORK OR BITUMINOUS PAVING SHALL OCCURE AFTER OCTOBER 15TH UNLESS AUTHORIZED BY THE CITY OF CHASKA.
5. STREET WIDTH TO BE DETERMINED BY PROJECTED TRAFFIC VOLUMES.
6. RECYCLE MATERIAL ACCEPTED AS CLASS 5 AGGREGATE BASE SUBSTITUTE IF MEETING GUIDELINES.



2335 Highway 36 W
 St. Paul, MN 55113
 www.stantec.com

TYPICAL SECTIONS FOR
 RESIDENTIAL STREETS
 RURAL SECTIONS

CHASKA, MINNESOTA

LAST REVISION:
 MAY 2023

PLATE NO.
 STR-6

Plot Date: 05/12/2023
 Plotting name: \\s0291-1p05601\special\handdrawn\plate02 - Chaska\2323 Detail Plates\STR-7.DWG
 Xref:

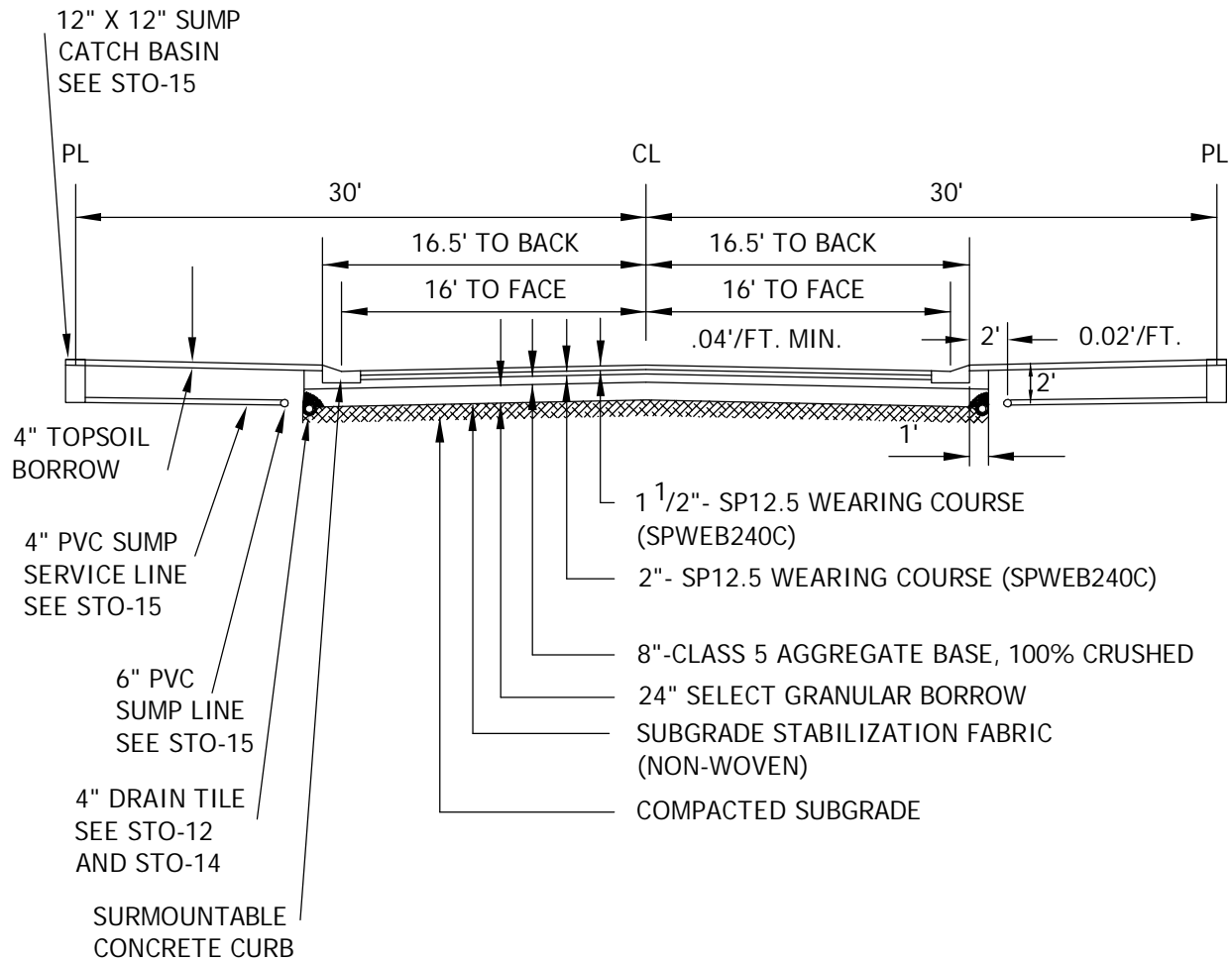

STANDARD STREET SECTION (7 TON)

NOTES:

1. ALL ORGANIC OR OTHER UNSUITABLE MATERIALS SHALL BE REMOVED FROM BENEATH THE ROADWAY.
2. A TEST ROLL OF THE PREPARED SUBGRADE SHALL BE PERFORMED BY THE OWNER IN THE PRESENCE OF A CITY INSPECTOR. THE CITY HAS THE AUTHORITY TO REQUIRE ADDITIONAL SUBGRADE CORRECTION OR ELIMINATE THE STABILIZATION FABRIC.
3. THE CITY RESERVES THE RIGHT TO MODIFY STREET SECTION AS REQUIRED.
4. NO CONCRETE WORK OR BITUMINOUS PAVING SHALL OCCURE AFTER OCTOBER 15TH UNLESS AUTHORIZED BY THE CITY OF CHASKA.
5. STREET WIDTH TO BE DETERMINED BY PROJECTED TRAFFIC VOLUMES.
6. RECYCLE MATERIAL ACCEPTED AS CLASS 5 AGGREGATE BASE SUBSTITUTE IF MEETING GUIDELINES.



2335 Highway 36 W
 St. Paul, MN 55113
 www.stantec.com

TYPICAL SECTIONS FOR
 RESIDENTIAL STREETS
 7 TON SECTION

CHASKA, MINNESOTA

LAST REVISION:
 MAY 2023

PLATE NO.
 STR-7

Plot Date: 05/12/2023
 Plotting name: \\s01291\ps01\special\handdrawn\plan02 - Chaska\2323 Detail Plans\STR-7A.dwg
 Xrefs:

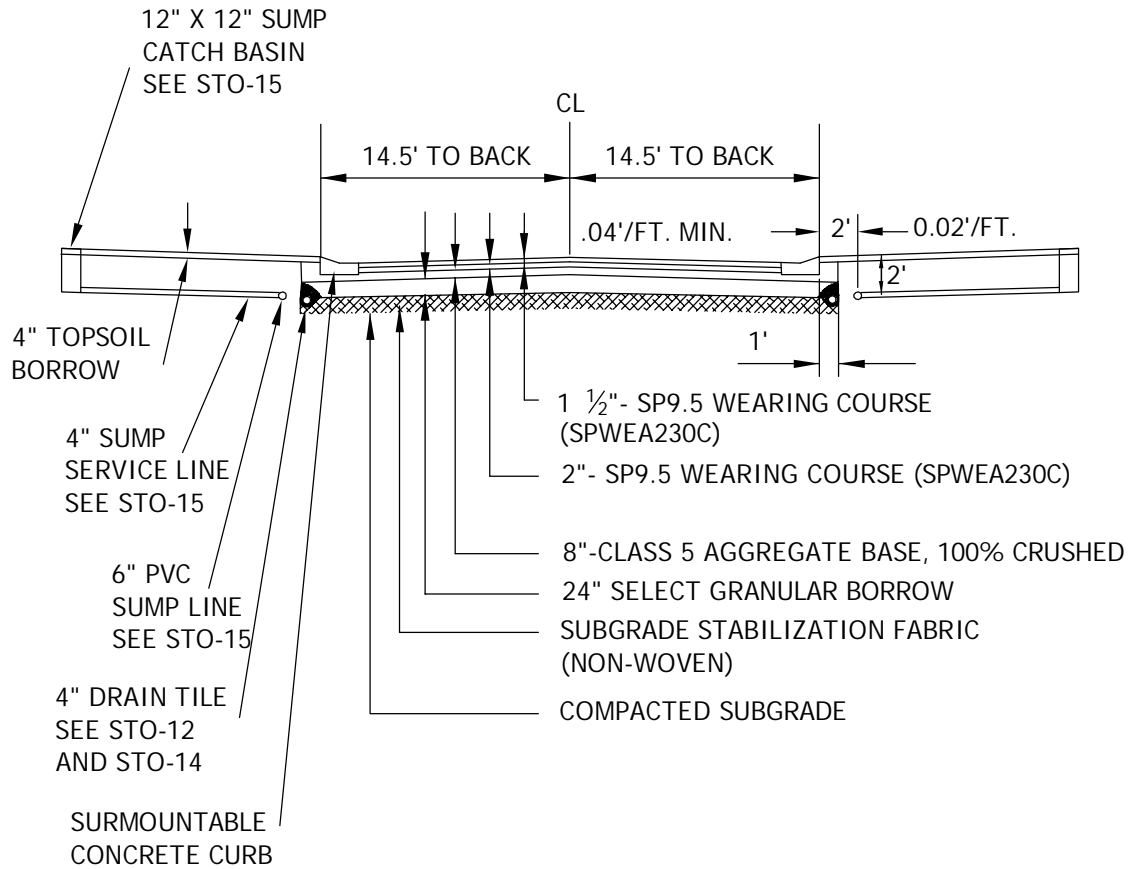

PRIVATE STREET WITH CONCRETE CURB AND GUTTER

NOTES:

1. ALL ORGANIC OR OTHER UNSUITABLE MATERIALS SHALL BE REMOVED FROM BENEATH THE ROADWAY.
2. A TEST ROLL OF THE PREPARED SUBGRADE SHALL BE PERFORMED BY THE OWNER IN THE PRESENCE OF A CITY INSPECTOR. THE CITY HAS THE AUTHORITY TO REQUIRE ADDITIONAL SUBGRADE CORRECTION OR ELIMINATE THE STABILIZATION FABRIC.
3. THE CITY RESERVES THE RIGHT TO MODIFY STREET SECTION AS REQUIRED.
4. NO CONCRETE WORK OR BITUMINOUS PAVING SHALL OCCURE AFTER OCTOBER 15TH UNLESS AUTHORIZED BY THE CITY OF CHASKA.
5. STREET WIDTH TO BE DETERMINED BY PROJECTED TRAFFIC VOLUMES.
6. RECYCLE MATERIAL ACCEPTED AS A CLASS 5 AGGREGATE BASE SUBSTITUTE IF MEETING GUIDELINES.



2335 Highway 36 W
 St. Paul, MN 55113
 www.stantec.com

TYPICAL SECTIONS FOR
 RESIDENTIAL STREETS
 PRIVATE SECTION

CHASKA, MINNESOTA

LAST REVISION:
 MAY 2023

PLATE NO.
 STR-7A

Plot Date: 05/12/2023
 Plotting Name: \\s0291\ps01\special\hand\draw\plm022 - Chaska\2223 Detail\Plan\STR-8.dwg
 Xref:

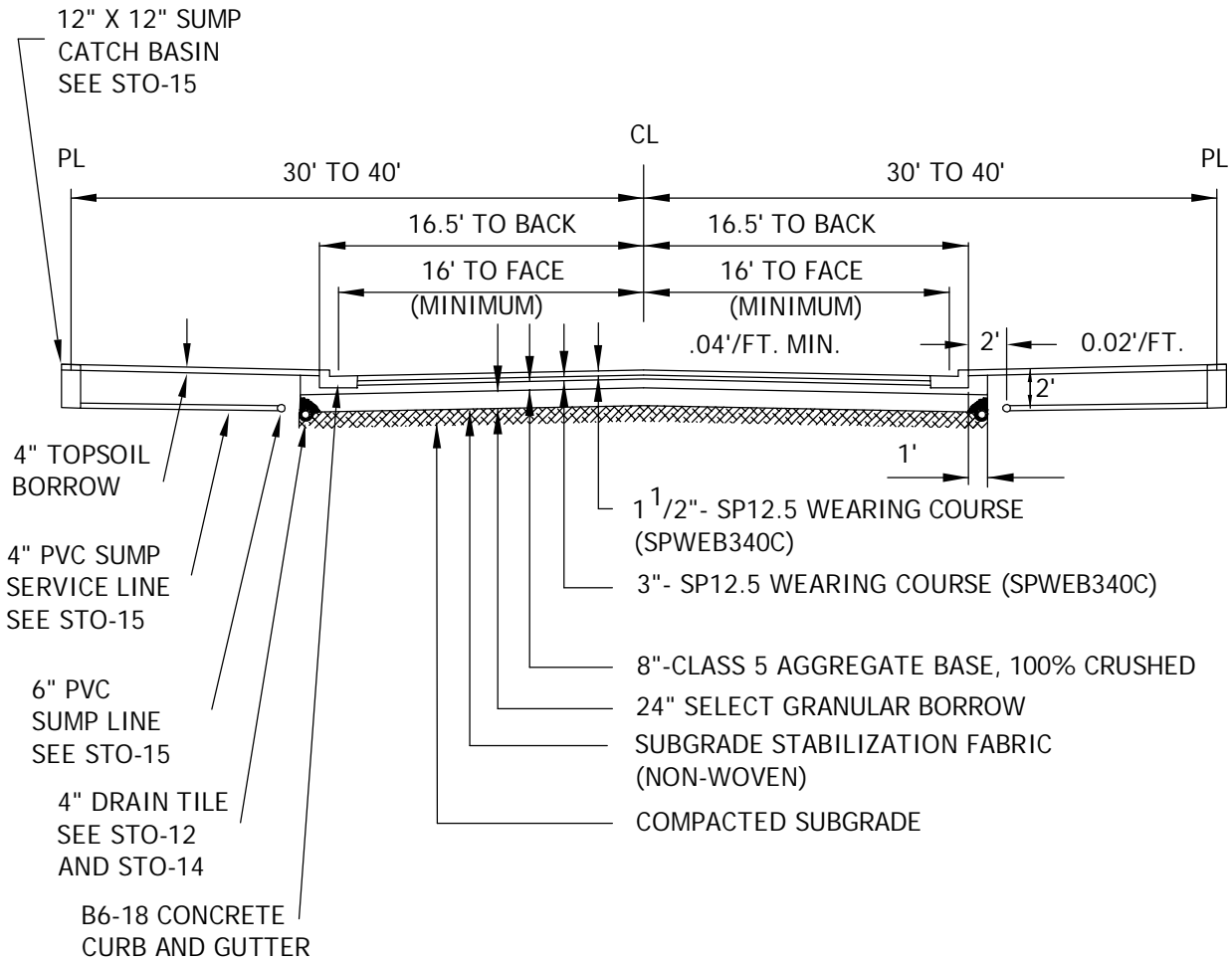

STANDARD STREET SECTION (9 TON)

NOTES:

1. ALL ORGANIC OR OTHER UNSUITABLE MATERIALS SHALL BE REMOVED FROM BENEATH THE ROADWAY.
2. A TEST ROLL OF THE PREPARED SUBGRADE SHALL BE PERFORMED BY THE OWNER IN THE PRESENCE OF A CITY INSPECTOR. THE CITY HAS THE AUTHORITY TO REQUIRE ADDITIONAL SUBGRADE CORRECTION OR ELIMINATE THE STABILIZATION FABRIC.
3. THE CITY RESERVES THE RIGHT TO MODIFY STREET SECTION AS REQUIRED.
4. NO CONCRETE WORK OR BITUMINOUS PAVING SHALL OCCURE AFTER OCTOBER 15TH UNLESS AUTHORIZED BY THE CITY OF CHASKA.
5. STREET WIDTH TO BE DETERMINED BY PROJECTED TRAFFIC VOLUMES.
6. RECYCLE MATERIAL ACCEPTED AS A CLASS 5 AGGREGATE BASE SUBSTITUTE IF MEETING GUIDELINES.



TYPICAL SECTION
9 TON

CHASKA, MINNESOTA

LAST REVISION:
 MAY 2023

PLATE NO.
STR-8

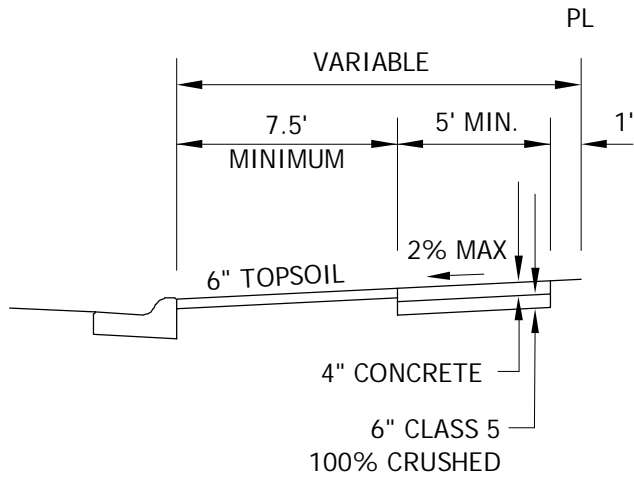

CONC. MIX: 3F52 (MANUAL PLACEMENT)
 3F32 (SLIP FORM PLACEMENT)

NEIGHBORHOOD SIDEWALK

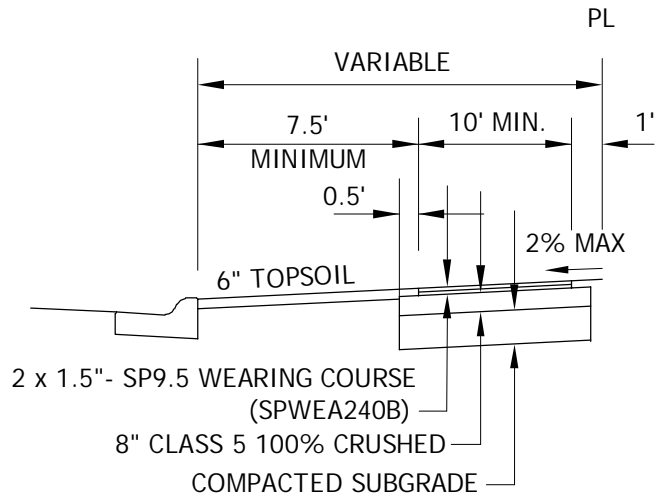

* BIT SHALL BE PLACED AND COMPACTED IN 2 LIFTS

COMMUNITY ROADWAY TRAIL
URBAN SECTION

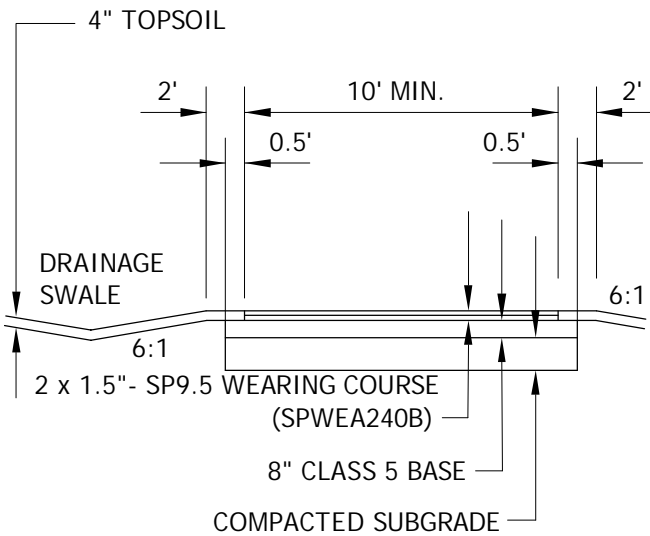

* BIT SHALL BE PLACED AND COMPACTED IN 2 LIFTS

COMMUNITY GREENWAY TRAIL

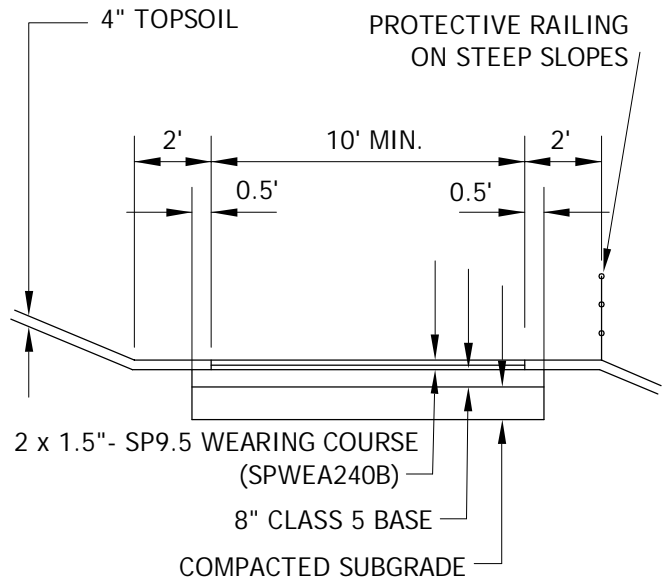

* BIT SHALL BE PLACED AND COMPACTED IN 2 LIFTS

COMMUNITY GREENWAY TRAIL

SIDE SLOPE LOCATION



2335 Highway 36 W
 St. Paul, MN 55113
 www.stantec.com

TYPICAL PLACEMENT AND SECTION
FOR WALKS AND TRAILS

CHASKA, MINNESOTA

LAST REVISION:
 MAY 2023

PLATE NO.
 STR-9

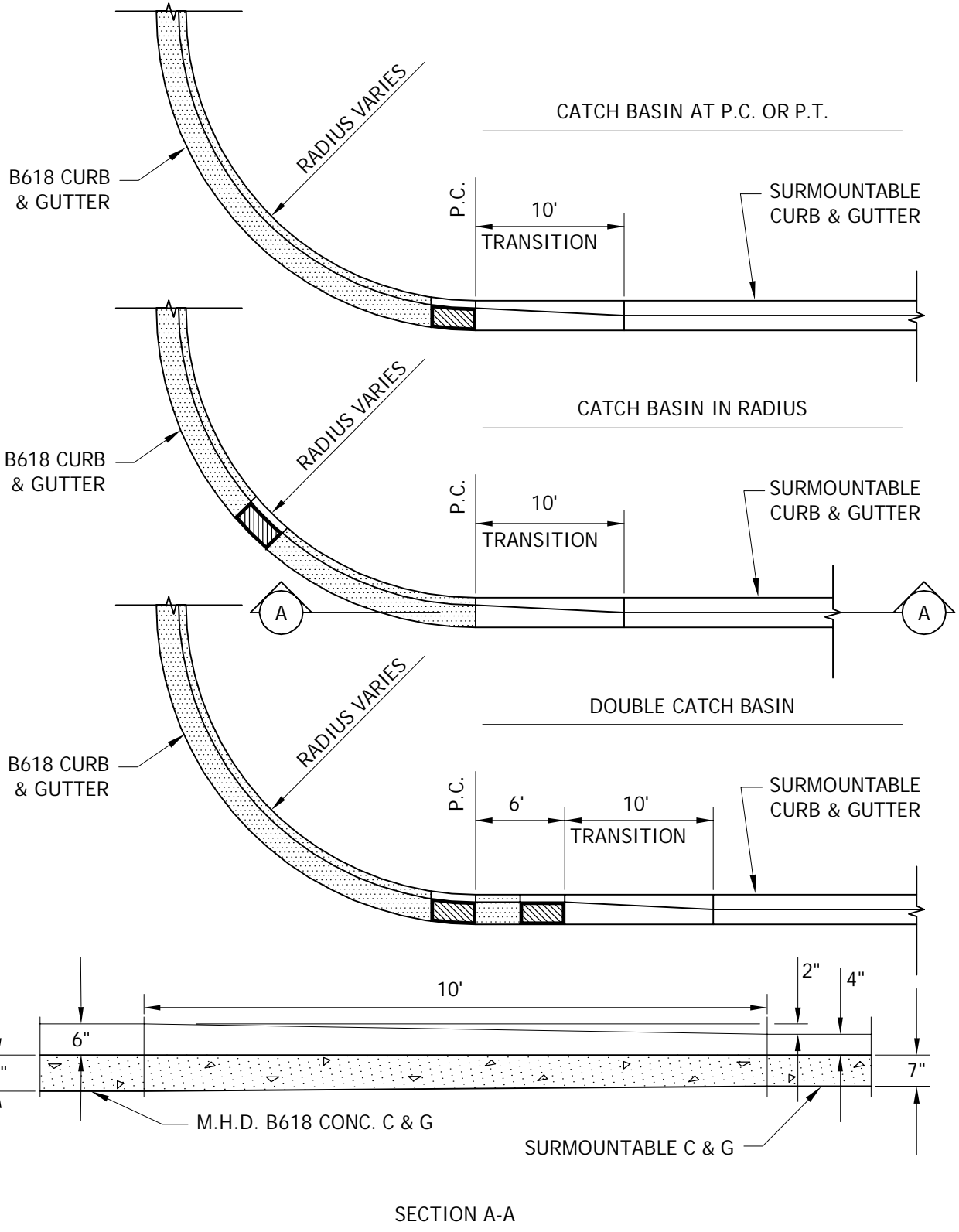

2335 Highway 36 W
 St. Paul, MN 55113
 www.stantec.com

CONCRETE CURB & GUTTER TRANSITION

CHASKA, MINNESOTA

LAST REVISION:
 OCT. 1989

PLATE NO.
 STR-10

Plot Date: 09/01/2023
 Plotting Name: R:\chaska\plans\2023\Chaska\2023 Detail Plans\STR-11.DWG
 Xref:

NOTES:

- PLACE NEENAH CAST IRON UNCOATED TRUNCATED DOMES THE WIDTH OF OPENING.
- ALL PEDESTRIAN CURB RAMP TO COMPLY WITH CURRENT MNDOT STANDARDS. IN CASES WHERE MNDOT STANDARDS DIFFER FROM CITY DETAIL, USE MNDOT STANDARDS.

① ADA REQUIRED TRUNCATED DOME PER MN/DOT STD. PLATE 7038A WITH CAULK SEALER

② CROSS SLOPE OF RAMP MAY NOT EXCEED .02 FT/FT AS CONSTRUCTED

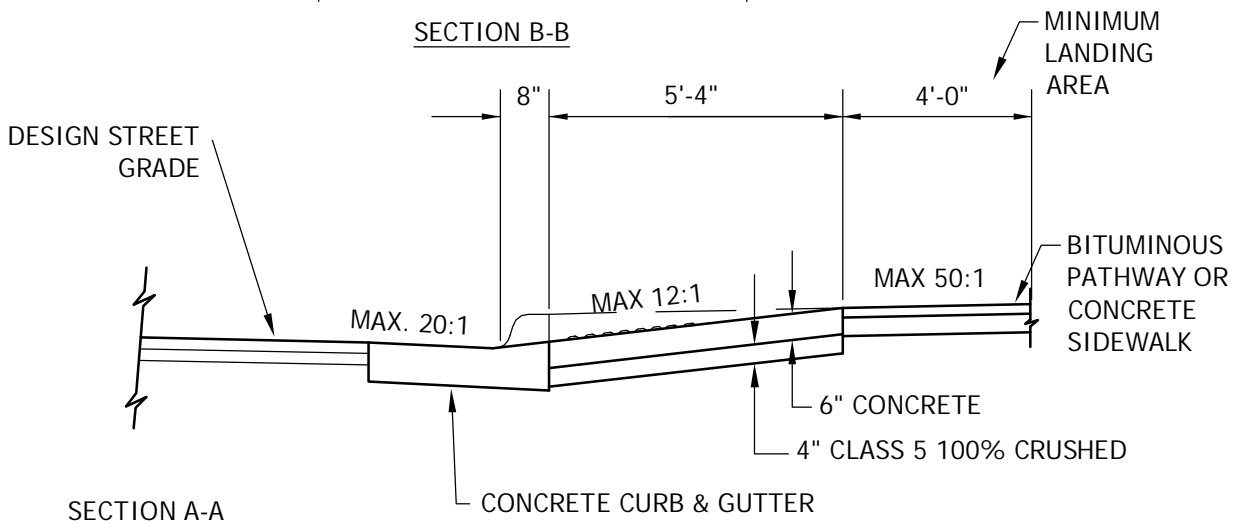
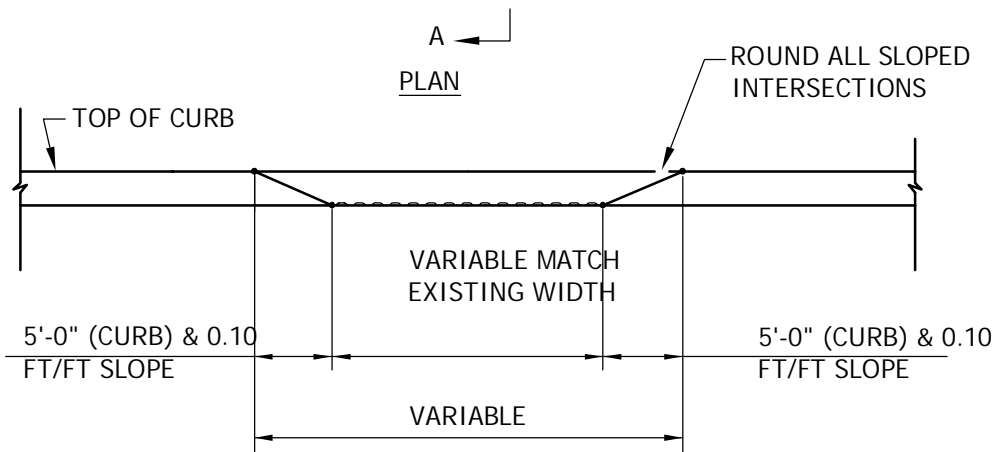
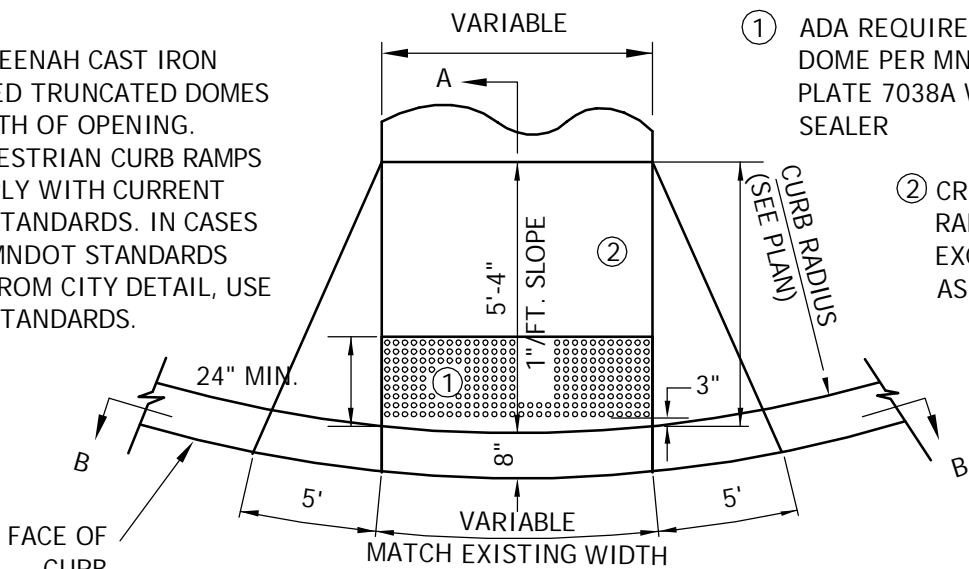

2335 Highway 36 W
 St. Paul, MN 55113
 www.stantec.com

**PEDESTRIAN CURB RAMP
 FOR PATHWAY/SIDEWALK**

CHASKA, MINNESOTA

LAST REVISION:
 AUG 2023

PLATE NO.
 STR-11

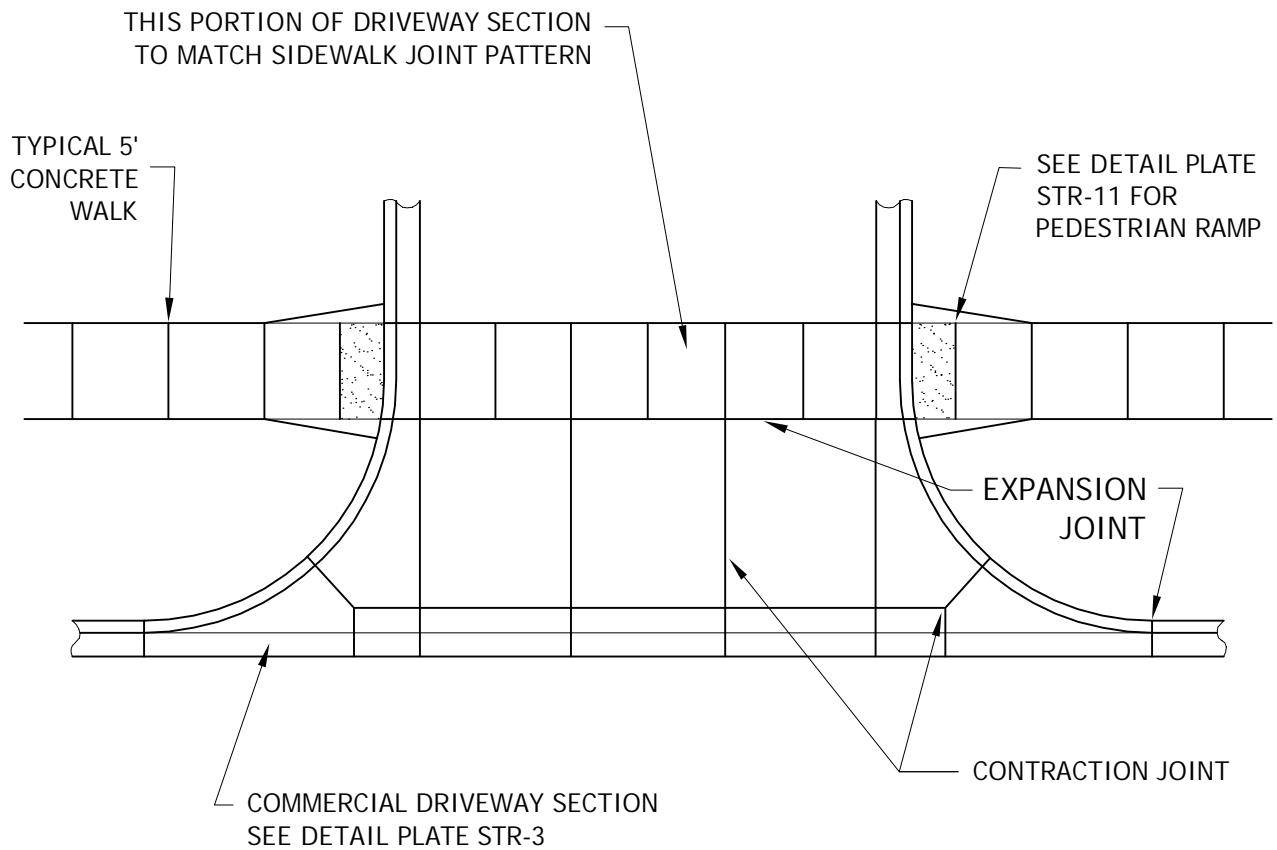

SEE DRIVEWAY DETAIL PLATE STR-2 FOR CONCRETE
THICKNESS AND PANEL WIDTH

ADDITIONAL JOINTS MAY BE ADDED AT
CONTRACTORS DISCRETION AND OWNERS APPROVAL



2335 Highway 36 W
St. Paul, MN 55113
www.stantec.com

TYPICAL SECTION FOR SIDEWALK
ACROSS COMMERCIAL DRIVEWAY

CHASKA, MINNESOTA

LAST REVISION:
APRIL 2016

PLATE NO.
STR-12

HEIGHT - 48 INCHES ABOVE STREET LEVEL

HAVE BOX EXTEND AS FAR IN FRONT OF SUPPORT POST AS POSSIBLE. (THIS PREVENTS POSSIBLE SNOW PLOW DAMAGE).

ADDRESS MUST BE ON SIDE OF BOX FROM WHICH CARRIER APPROACHES IN LETTERS ABOUT ONE INCH HIGH. (OR ON FRONT WHERE BOXES ARE GROUPED).

BOX MUST BE LOCATED SO CARRIER CAN SERVE WITHOUT LEAVING VEHICLE.

NOTES:

MAILBOX SHOULD NOT EXTEND BEYOND BACK OF CURB.

ALL POSTS TO BE A MINIMUM OF 18" BEHIND BACK OF CURB.

DIMENSIONS AS PER U.S. POSTAL SERVICE

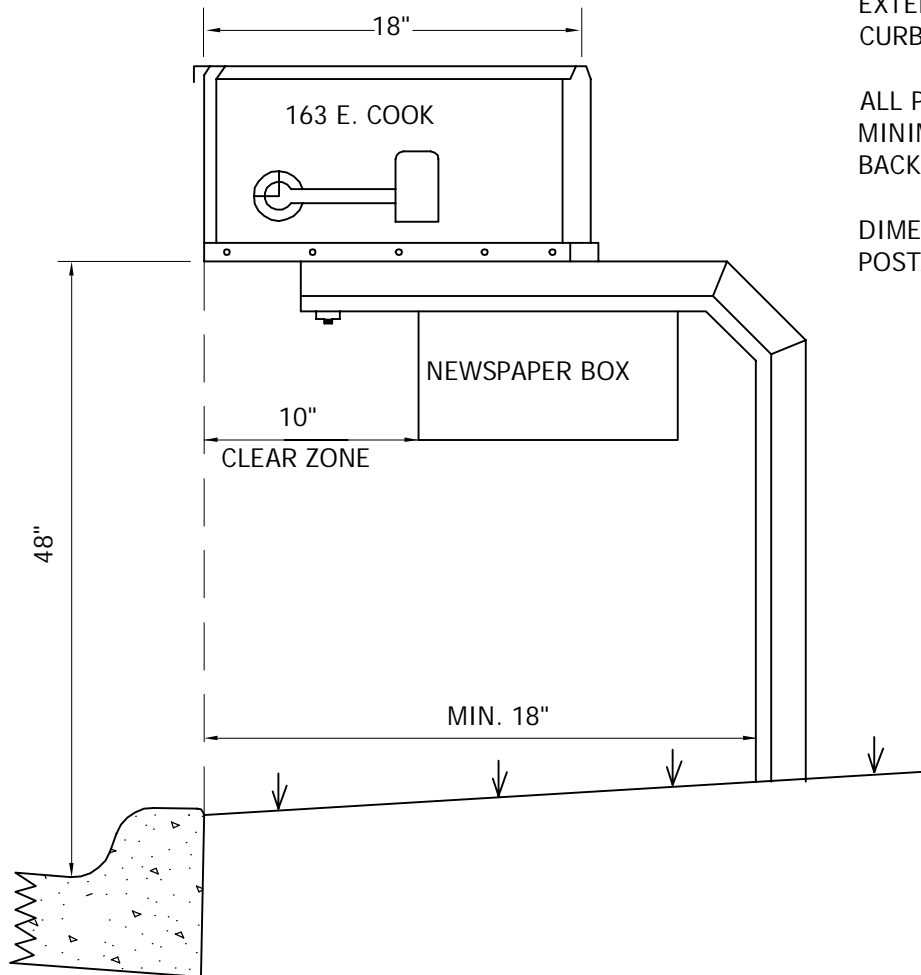

2335 Highway 36 W
St. Paul, MN 55113
www.stantec.com

MAILBOX INSTALLATION

CHASKA, MINNESOTA

LAST REVISION:
APRIL 2004

PLATE NO.
STR-13

NOTES:
POST JOINT BOLTS TO BE PLACED AT 1", AND 5" HOLE SPACING.

BOLT THROUGH 11TH HOLE IS THE STOP BOLT AT THE REINFORCEMENT BAND

5/16" X 3" STAINLESS STEEL BOLT WITH NYLON INSERT LOCK NUTS. PLACE STEEL WASHER ON TELSPAR SIDE.

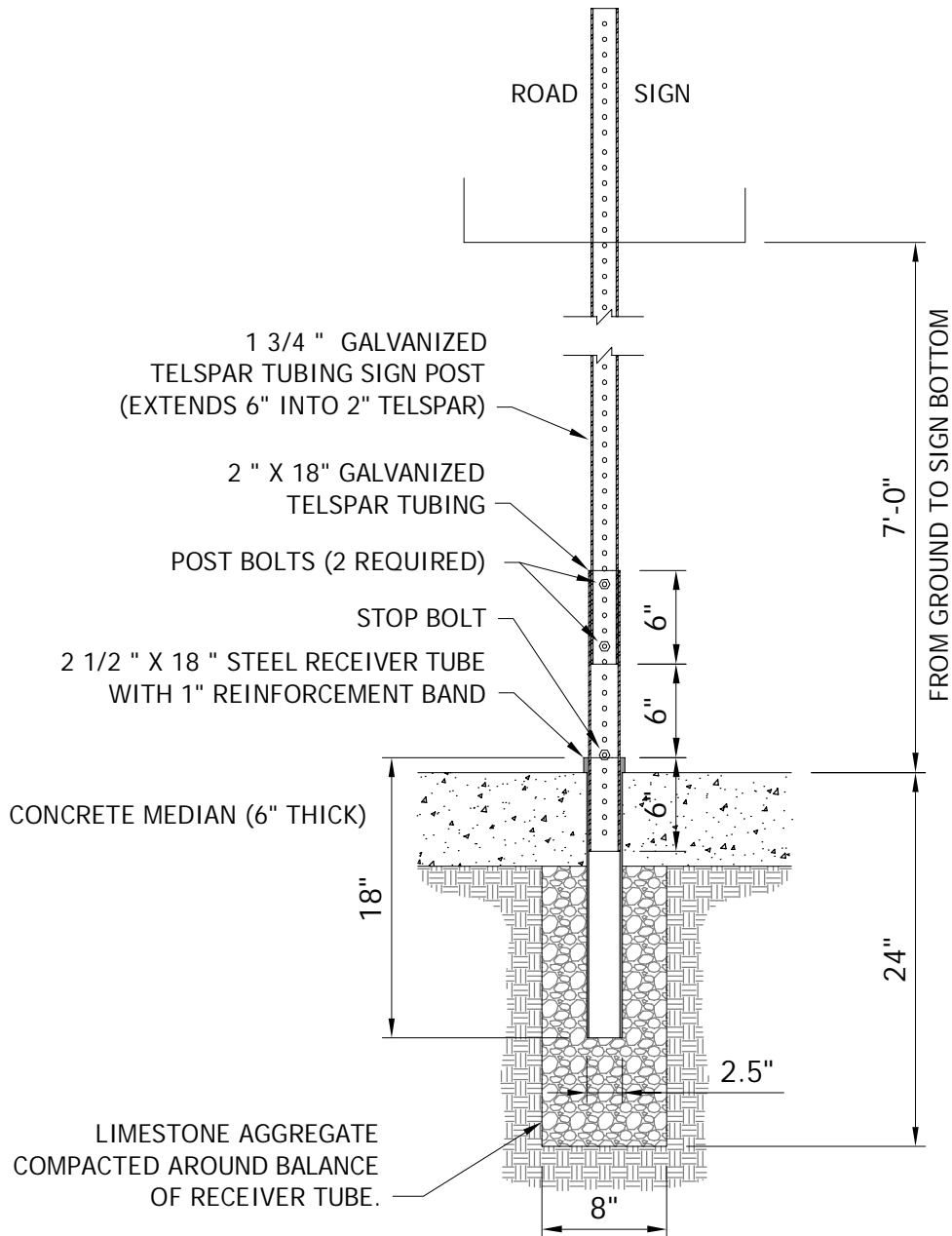

LAST REVISION:



2335 Highway 36 W
St. Paul, MN 55113
www.stantec.com

MEDIAN SIGN
INSTALLATION DETAIL
CHASKA, MINNESOTA

JUNE 2011

PLATE NO.
STR-14

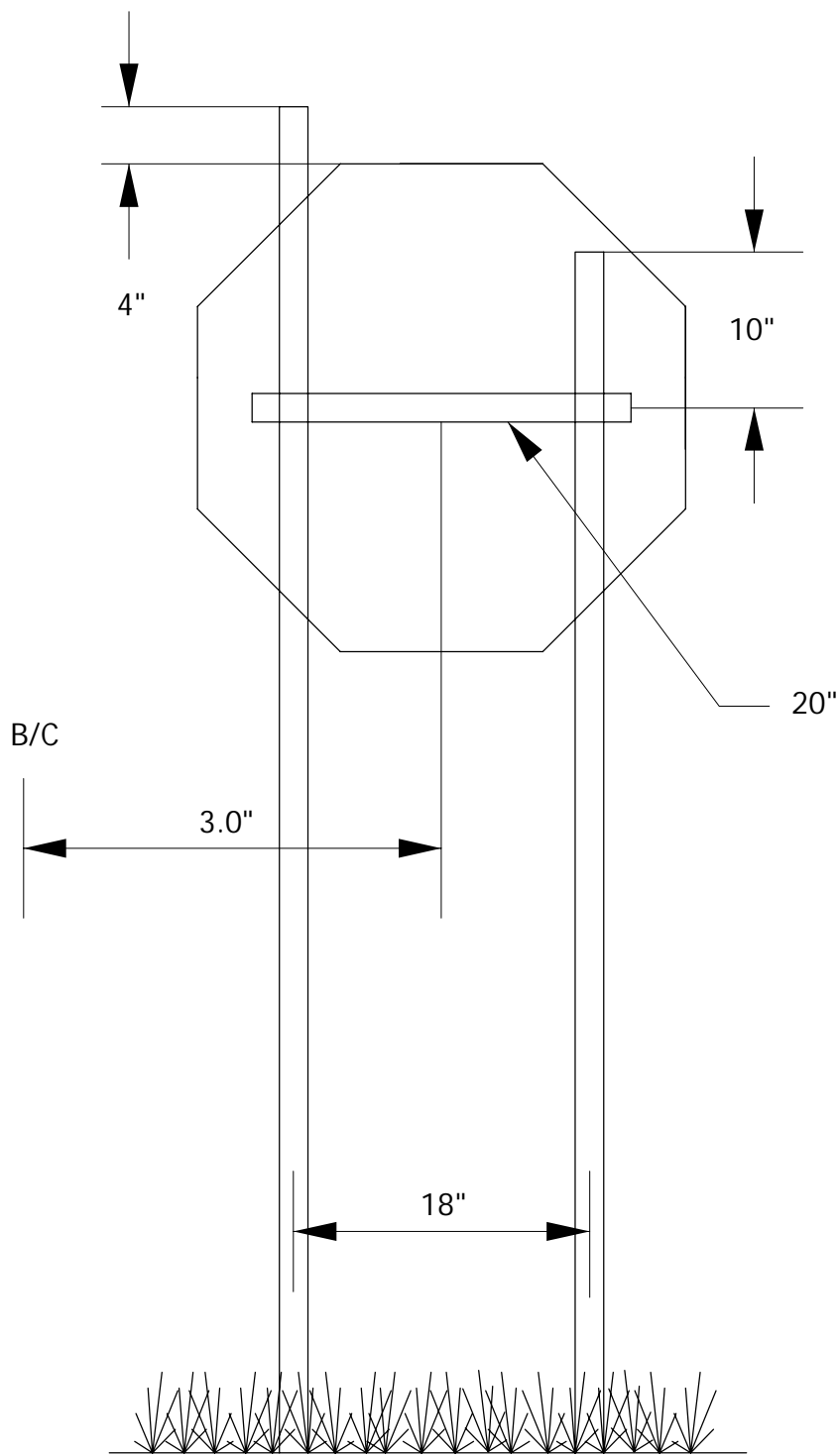

NOTES:
STOP SIGNS SHOULD BE
INSTALLED 3' BEHIND
B/C

ALL STOP SIGNS SHALL
BE INSTALLED WITH
TWO POSTS UNLESS
APPROVED BY OWNER



2335 Highway 36 W
St. Paul, MN 55113
www.stantec.com

STOP SIGN INSTALLATION DETAIL

CHASKA, MINNESOTA

LAST REVISION:
JUNE 2012

PLATE NO.
STR-15

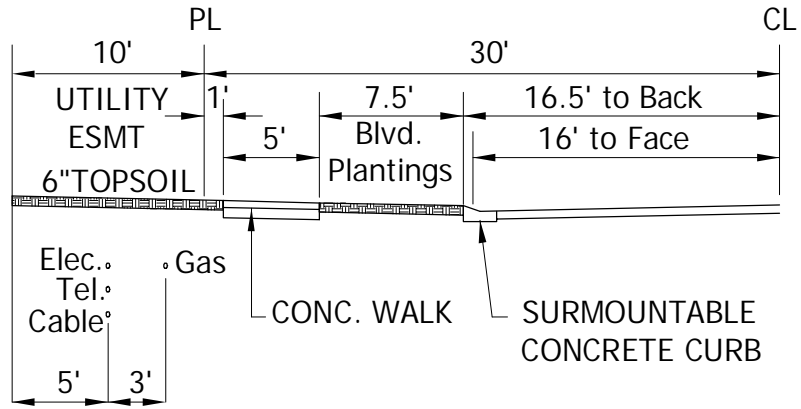

STANDARD RESIDENTIAL STREET

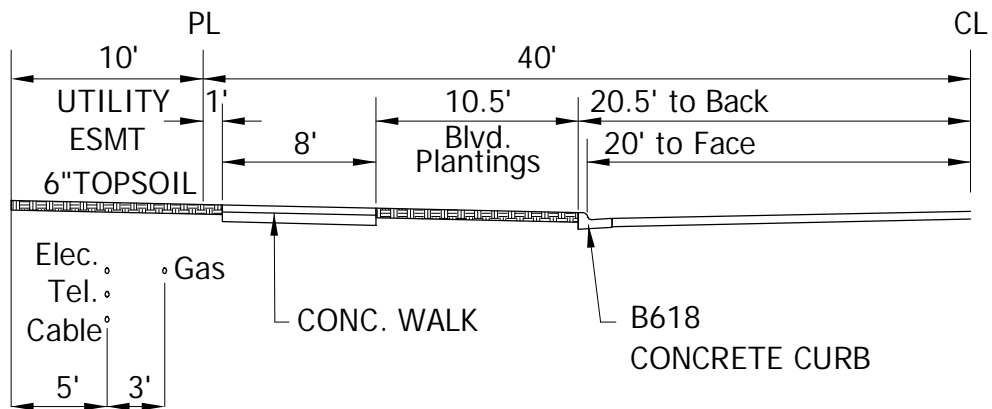

STANDARD COMMERCIAL STREET

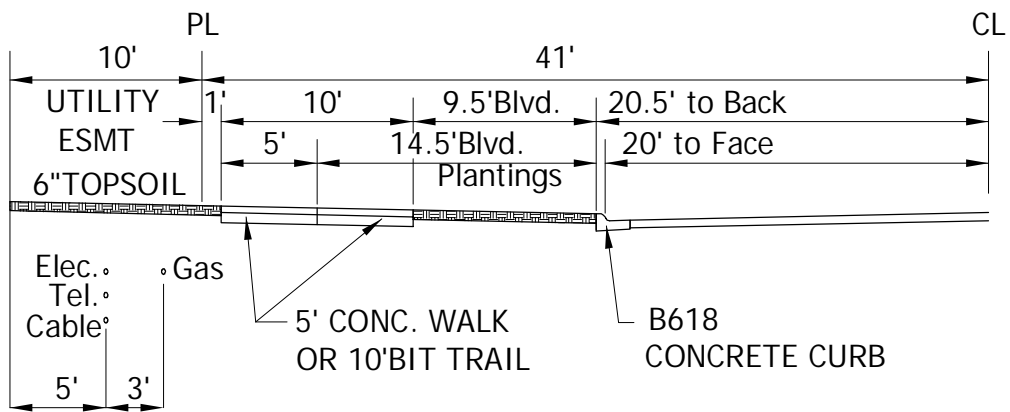

STANDARD COLLECTOR STREET



2335 Highway 36 W
 St. Paul, MN 55113
 www.stantec.com

TYPICAL STREET
 COMPONENTS/DIMENSIONS
 RESIDENTIAL, COMMERCIAL & COLLECTOR
 CHASKA, MINNESOTA

LAST REVISION:
 APRIL 2016

PLATE NO.
 STR-16

BARRICADES (GEN-4)
PLACE AS DIRECTED
BY THE CITY

FUTURE SEWER AND WATER LINES ARE TO BE
EXTENDED BEYOND THE END OF THE STREET

A HYDRANT & GATE VALVE SHALL BE PLACED AT
THE END OF THE WATERMAIN

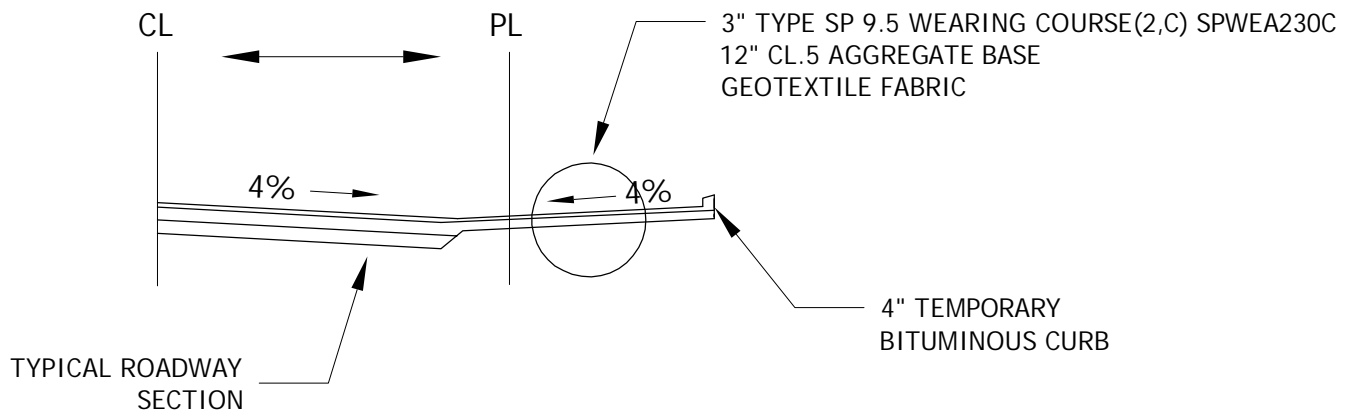
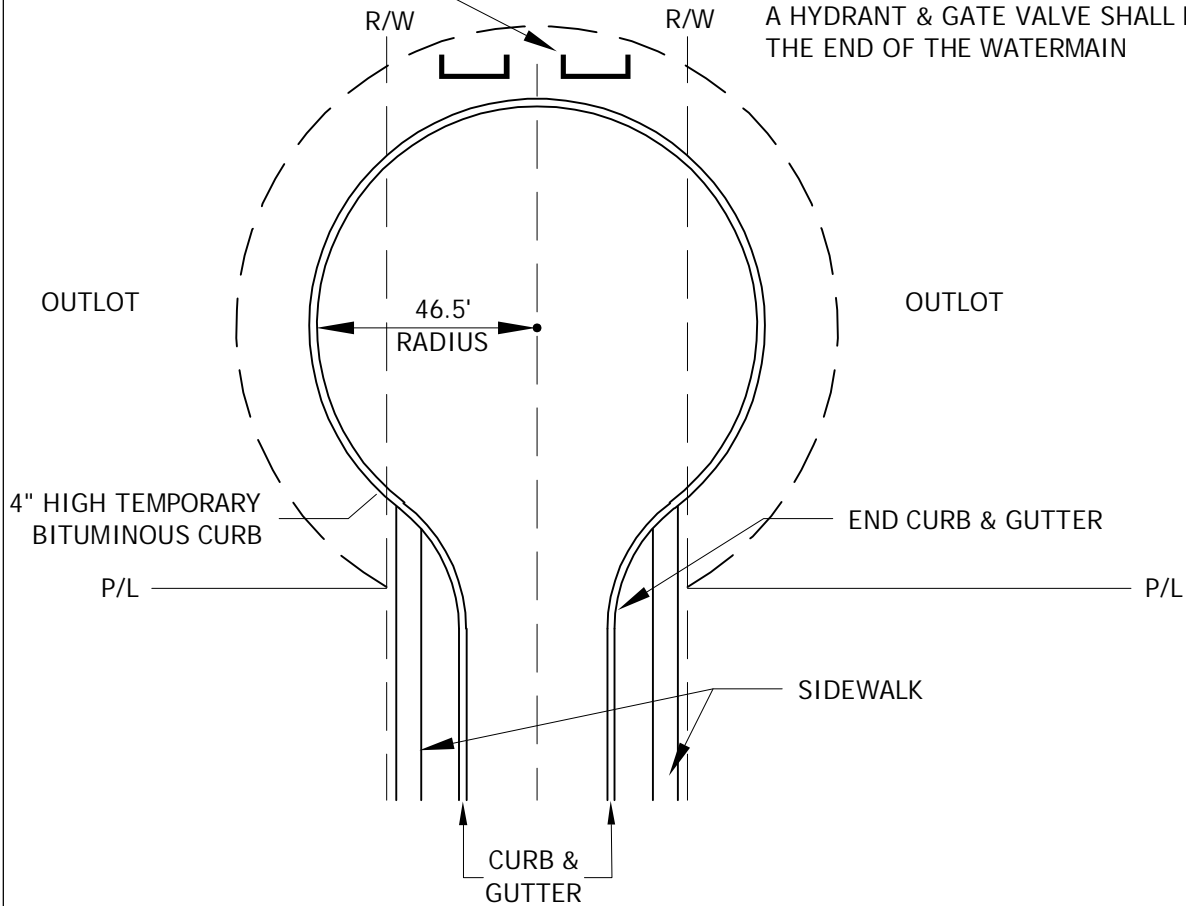

REFERENCE CURRENT INTERNATIONAL FIRE CODE APPENDIX D FOR ALTERNATE ACCESS.
CITY FIRE MARSHAL TO APPROVE ALL ALTERNATE ACCESS.



2335 Highway 36 W
St. Paul, MN 55113
www.stantec.com

TEMPORARY BITUMINOUS CUL-DE-SAC

CHASKA, MINNESOTA

LAST REVISION:
MAY 2023

PLATE NO.
STR-17

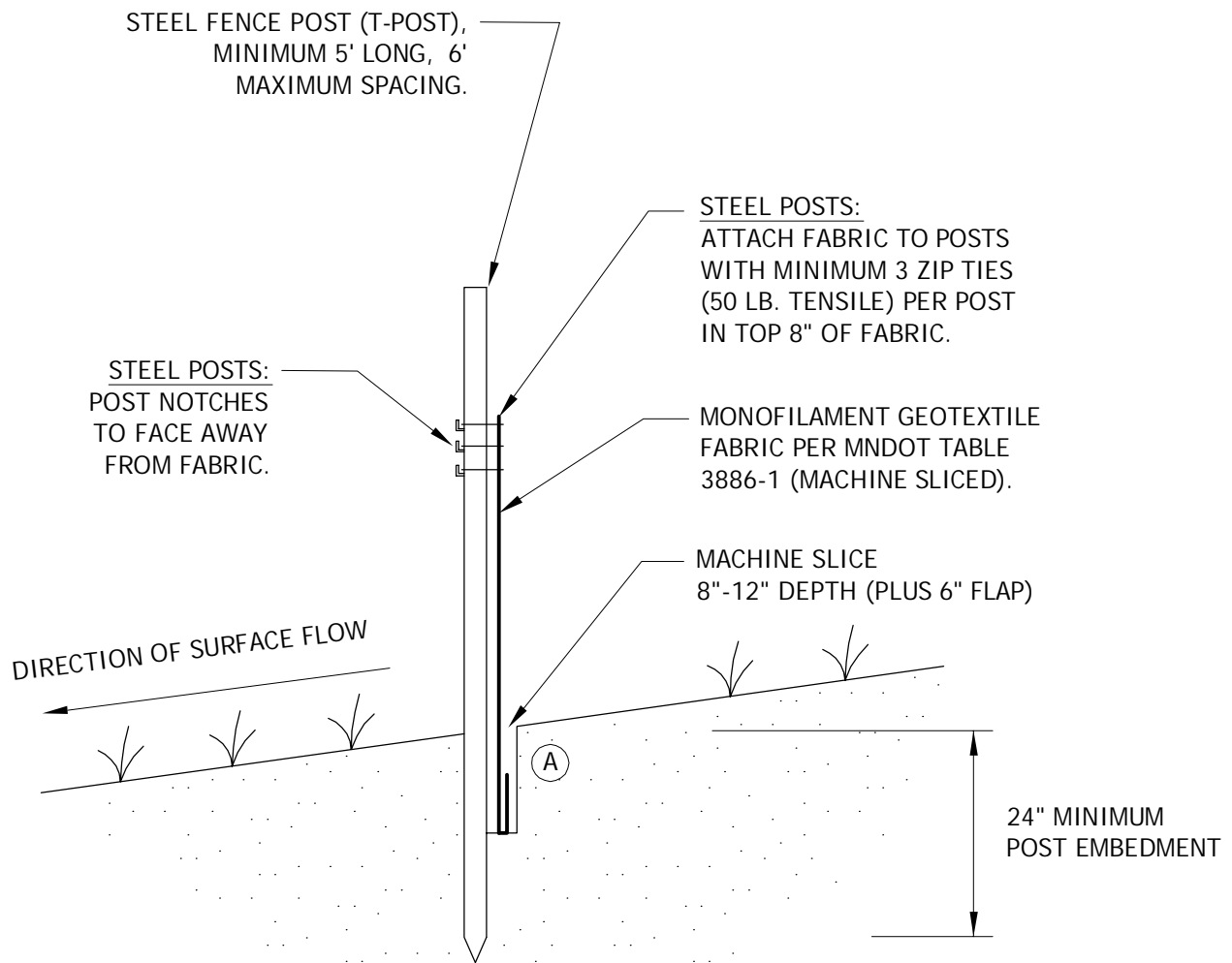

NOTE:

THE MACHINE SLICED METHOD (THIS DETAIL) IS THE STANDARD SILT FENCE INSTALLATION METHOD. HEAVY DUTY (ERO-1B) SILT FENCE INSTALLATION METHODS SHOULD ONLY BE USED WHEN APPROVED OR DIRECTED BY THE CITY.

(A) COMPACTION:

AFTER "SLICING" IN THE FABRIC AND *BEFORE* INSTALLATION OF STEEL POSTS, DRIVE INSTALLATION EQUIPMENT OVER THE "SLICE" WHILE FABRIC IS LAYING ON THE GROUND. *THEN* INSTALL THE POSTS AND PULL UP FABRIC TO ATTACH AT A UNIFORM HEIGHT.



Stantec

2335 Highway 36 W
St. Paul, MN 55113
www.stantec.com

**SILT FENCE
MACHINE SLICED**

CHASKA, MN

LAST REVISION:
APRIL 2011

PLATE NO.
ERO-1A

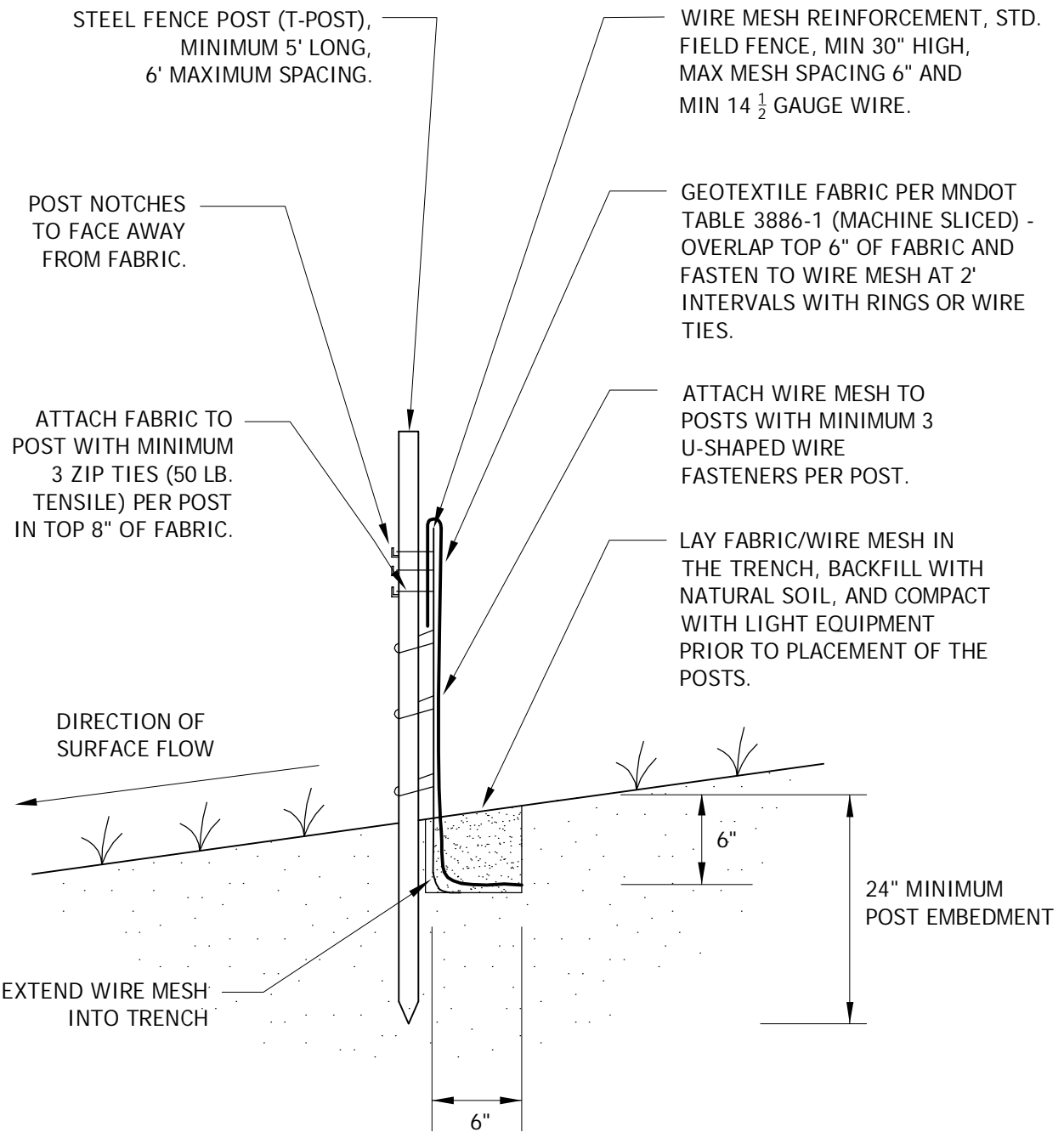

NOTE:
SPLICING WILL BE MADE AT OPPOSING SILT FENCE POSTS BY PLACING
POSTS AND SILT FENCE NEXT TO EACH OTHER AND ROTATING 360°.



2335 Highway 36 W
St. Paul, MN 55113
www.stantec.com

SILT FENCE HEAVY DUTY

CHASKA, MINNESOTA

LAST REVISION:
APRIL 2008

PLATE NO.
ERO-1B

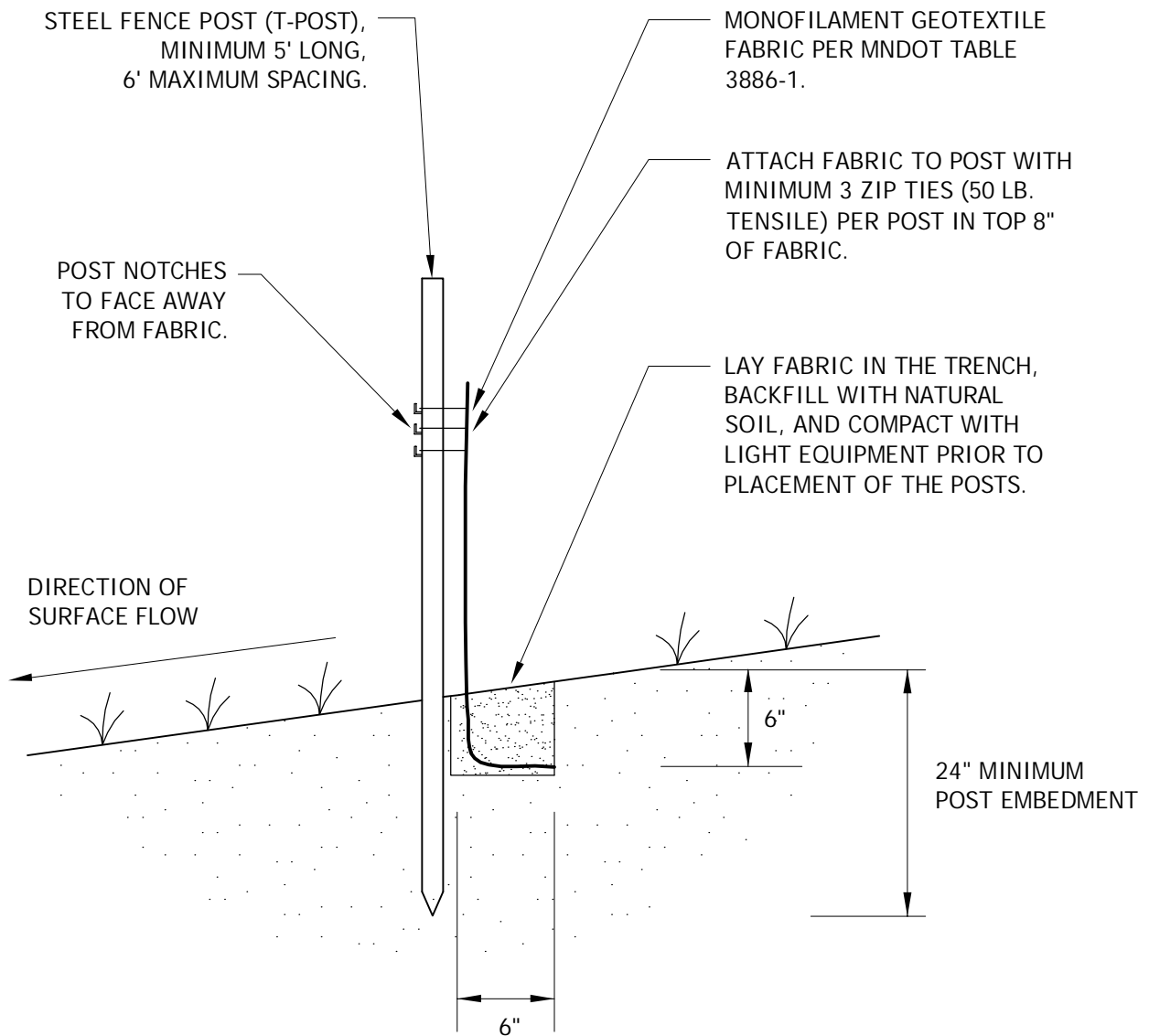

NOTES:

1. SPLICING WILL BE MADE AT OPPOSING SILT FENCE POSTS BY PLACING POSTS AND SILT FENCE NEXT TO EACH OTHER AND ROTATING 360°.
2. SILT FENCE IS MACHINE SLICED TYPE SILT FENCE THAT IS HAND INSTALLED IN AREAS INACCESSIBLE TO EQUIPMENT DUE TO SPACE LIMITATIONS, WET SOILS, STEEP SLOPES, ETC.



2335 Highway 36 W
St. Paul, MN 55113
www.stantec.com

**SILT FENCE
STANDARD**

CHASKA, MINNESOTA

LAST REVISION:
APRIL 2008

PLATE NO.
ERO-1C

PLAN VIEW

I. SPACING REQUIREMENTS

DIRECTION OF SURFACE FLOW

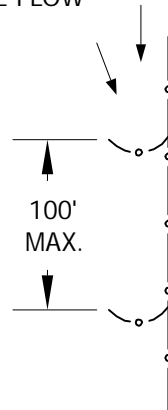

NOTE: SPACING DISTANCES WILL VARY, BUT ARE NOT TO EXCEED 100 FEET.

II. SIZING REQUIREMENTS: J15, J25

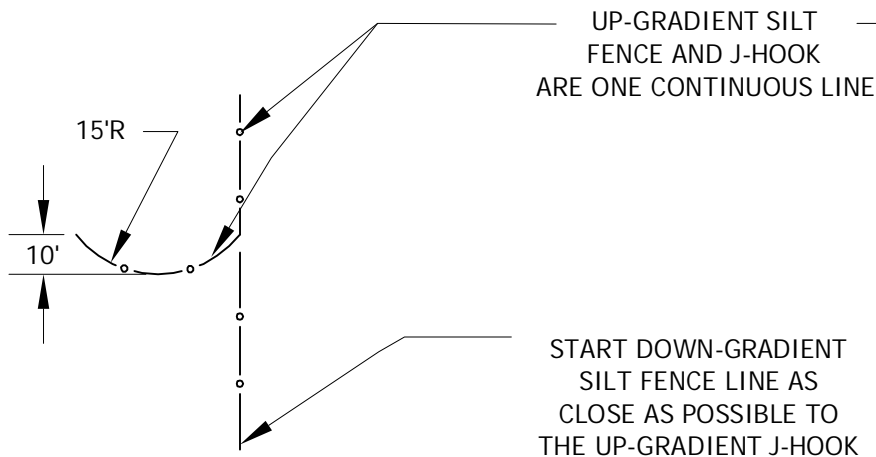

UP-GRADIENT SILT FENCE AND J-HOOK ARE ONE CONTINUOUS LINE

START DOWN-GRADIENT SILT FENCE LINE AS CLOSE AS POSSIBLE TO THE UP-GRADIENT J-HOOK

J15 - FOR CATCHMENT AREA < 0.25 ACRES

J25 - FOR CATCHMENT AREA \geq 0.25 ACRES

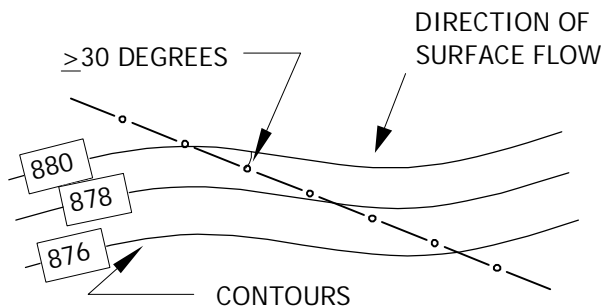

NOTE: J-HOOKS SHALL BE USED WHEN THE SILT FENCE IS INSTALLED AT AN ANGLE OF 30 DEGREES OR GREATER FROM PARALLEL TO THE CONTOURS.



2335 Highway 36 W
 St. Paul, MN 55113
 www.stantec.com

SILT FENCE
 J-HOOK

CHASKA, MINNESOTA

LAST REVISION:
 APRIL 2008

PLATE NO.
 ERO-1D

ANCHOR TRENCH
(SEE DETAIL AND NOTES BELOW)

OVERLAP END JOINTS
MINIMUM OF 6" AND STAPLE
OVERLAP AT 1.5' INTERVALS.

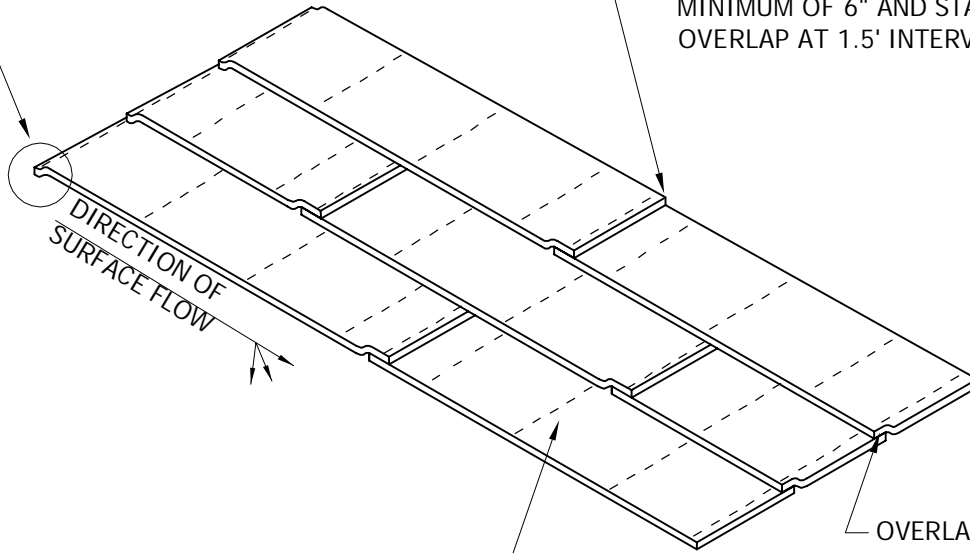

STAPLE PATTERN/DENSITY SHALL
FOLLOW MANUFACTURERS
SPECIFICATIONS

OVERLAP
LONGITUDINAL JOINTS
MINIMUM OF 6"

ANCHOR TRENCH

1. DIG 6" X 6" TRENCH
2. LAY BLANKET IN TRENCH
3. STAPLE AT 1.5' INTERVALS
4. BACKFILL WITH NATURAL SOIL AND COMPACT
5. BLANKET LENGTH SHALL NOT EXCEED 100'
WITHOUT AN ANCHOR TRENCH

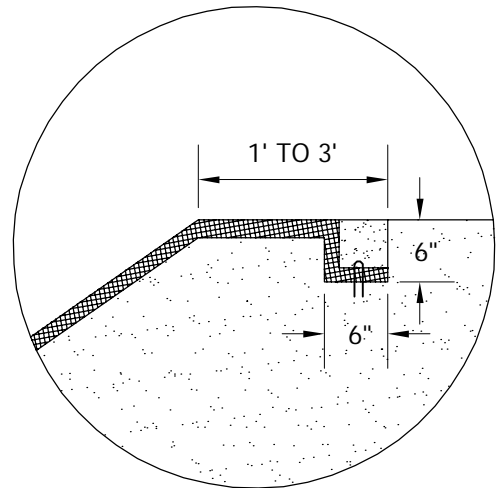

NOTE:

SLOPE SURFACE SHALL BE FREE OF ROCKS, SOIL CLUMPS,
STICKS, VEHICLE IMPRINTS, AND GRASS. BLANKETS SHALL
HAVE GOOD SOIL CONTACT.



2335 Highway 36 W
St. Paul, MN 55113
www.stantec.com

**EROSION CONTROL BLANKET
INSTALLATION**

CHASKA, MINNESOTA

LAST REVISION:
APRIL 2008

PLATE NO.
ERO-2

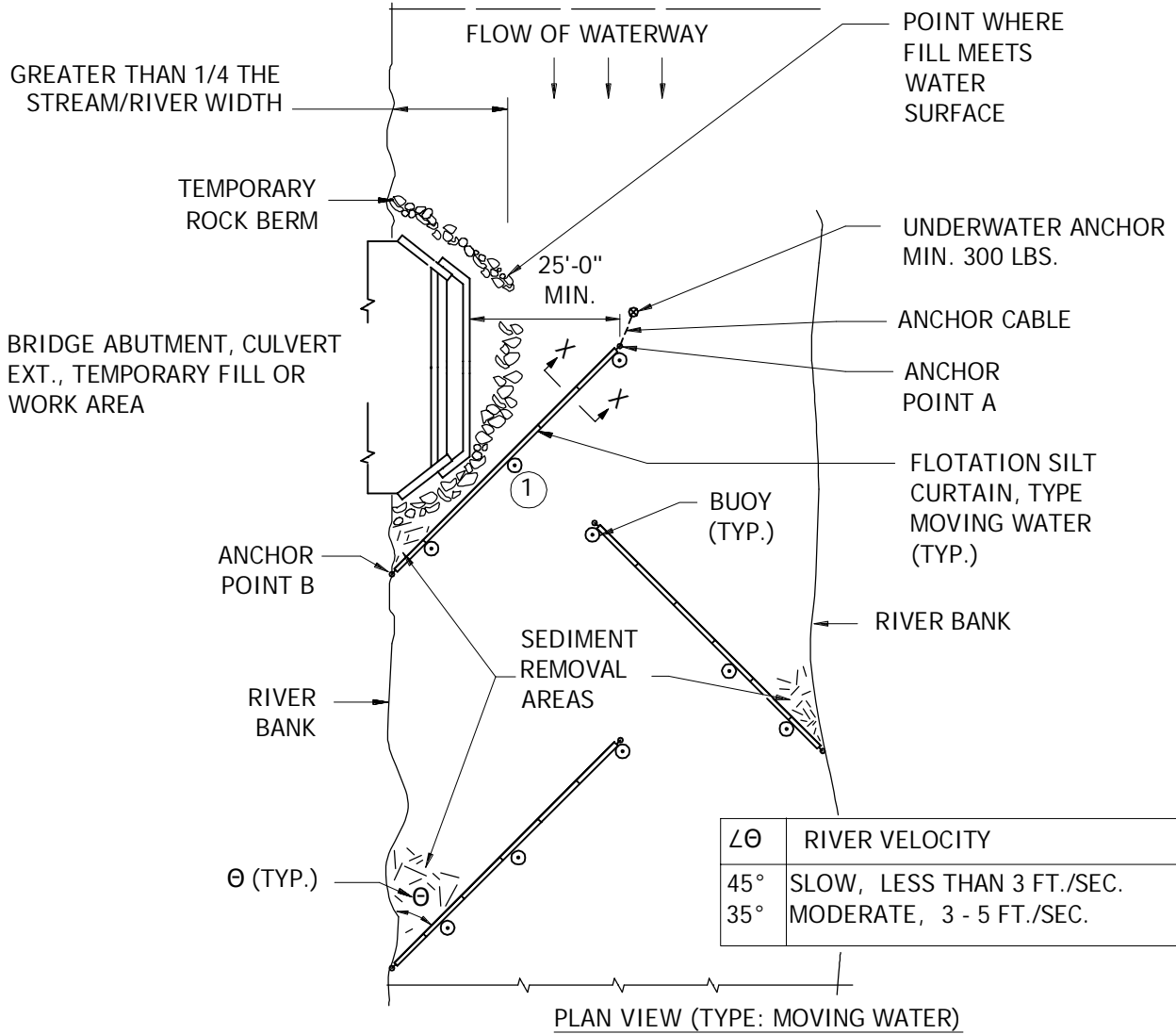

NOTE:

1 100 FT. MAX. SPACING BETWEEN ANCHORS. ANCHORS WEIGH MIN. 40 LBS.

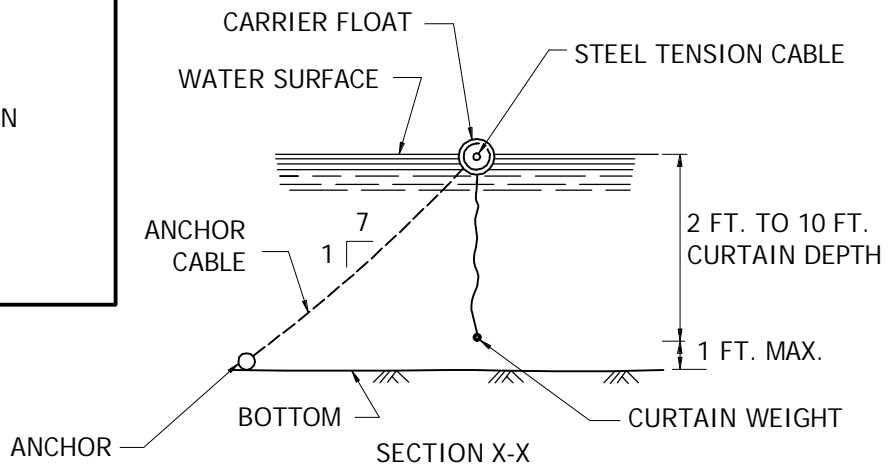

2335 Highway 36 W
 St. Paul, MN 55113
 www.stantec.com

**FLOATING SILT FENCE
 IN MOVING WATER**

CHASKA, MINNESOTA

LAST REVISION:
 APRIL 2008

PLATE NO.
ERO-3A

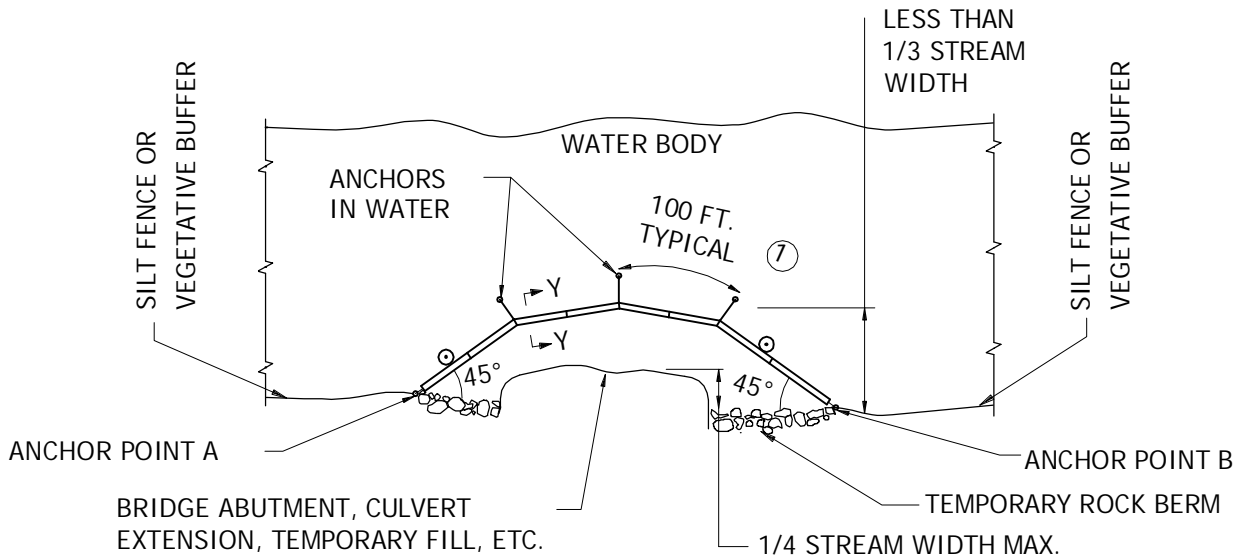

PLAN VIEW (TYPE: WORK AREA)

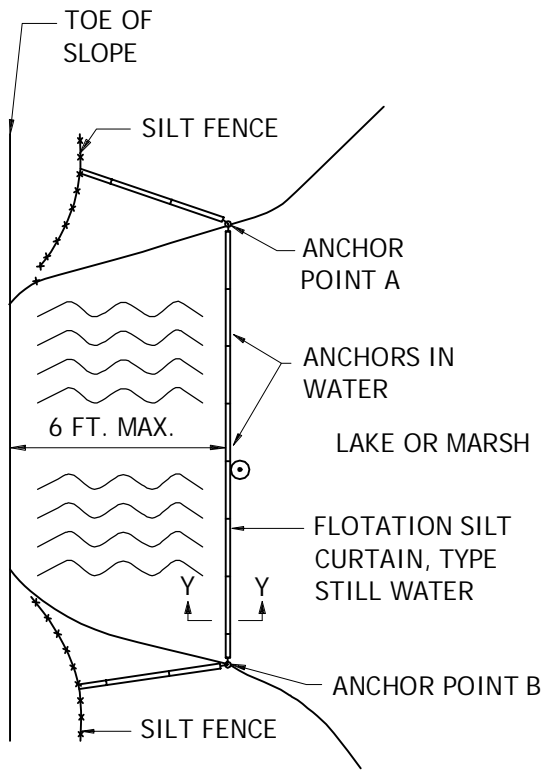

PLAN VIEW (TYPE: STILL WATER)

NOTES:

- ① 100 FT. MAX. SPACING BETWEEN ANCHORS. ANCHORS WEIGH MIN. 40 LBS.

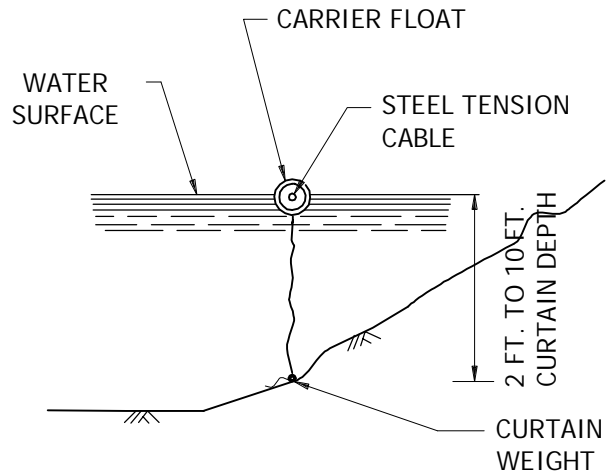

SECTION Y-Y



2335 Highway 36 W
 St. Paul, MN 55113
 www.stantec.com

FLOATING SILT FENCE
 IN STILL WATER

CHASKA, MINNESOTA

LAST REVISION:
 APRIL 2008

PLATE NO.
 ERO-3B

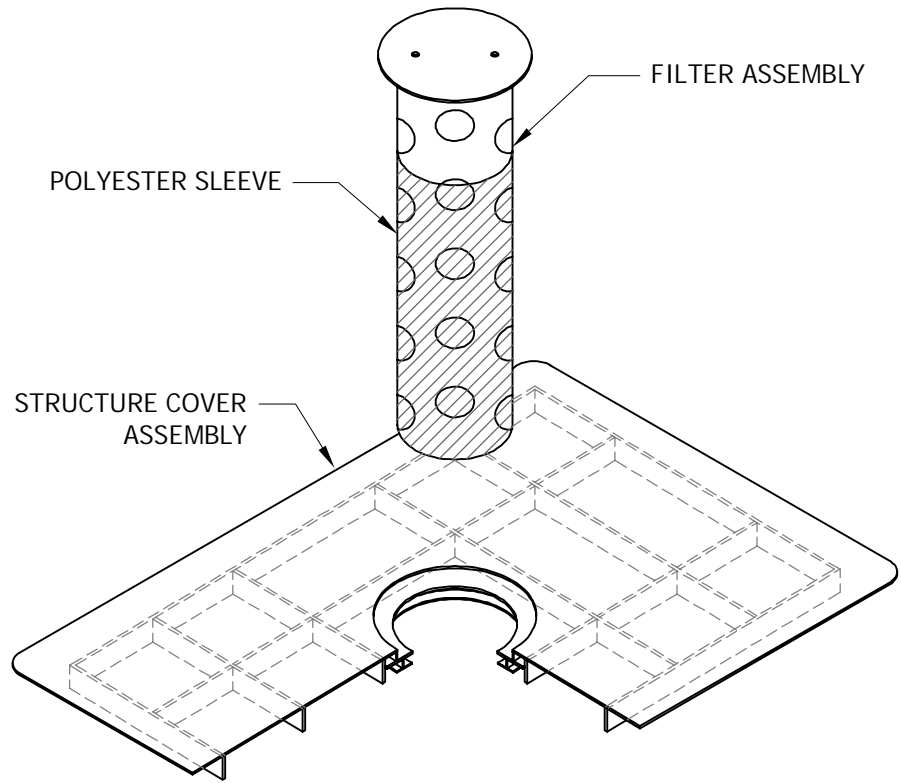

ISOMETRIC VIEW

DEVICES TO BE INSTALLED IMMEDIATELY UPON INSTALLATION OF CONCRETE STRUCTURE OR TOP SLAB.

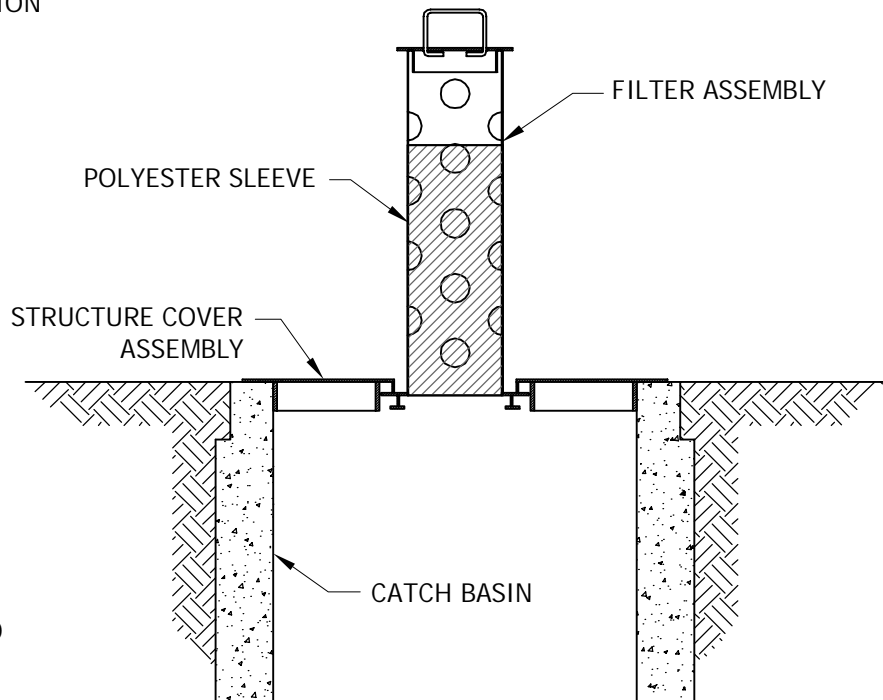

IN-PLACE ELEVATION VIEW

NOTE: ALL OTHER INLET PROTECTION DEVICES MUST BE APPROVED BY OWNER PRIOR TO INSTALLATION.



2335 Highway 36 W
St. Paul, MN 55113
www.stantec.com

INLET PROTECTION FOR CATCH BASIN BEFORE CURB CONSTRUCTION

CHASKA, MINNESOTA

LAST REVISION:
APRIL 2008

PLATE NO.
ERO-4A

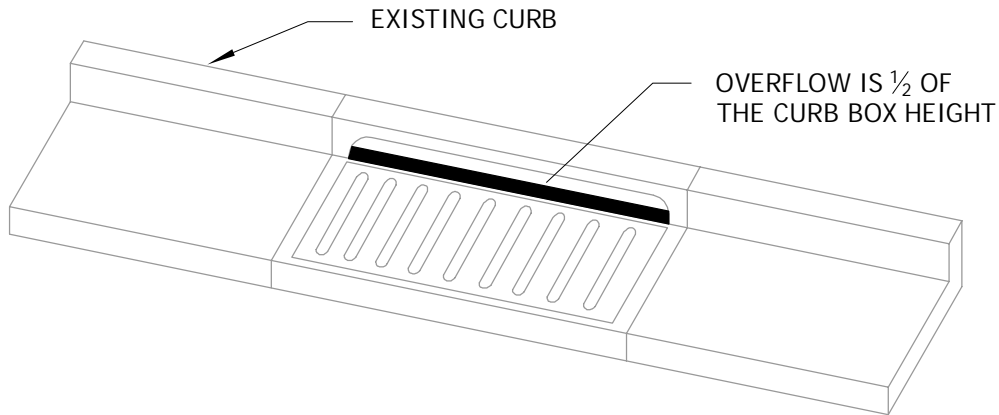

PLAN

WIMCO ROAD DRAIN CG-23* HIGH FLOW
INLET PROTECTION CURB AND GUTTER MODEL
OR CITY APPROVED EQUAL.

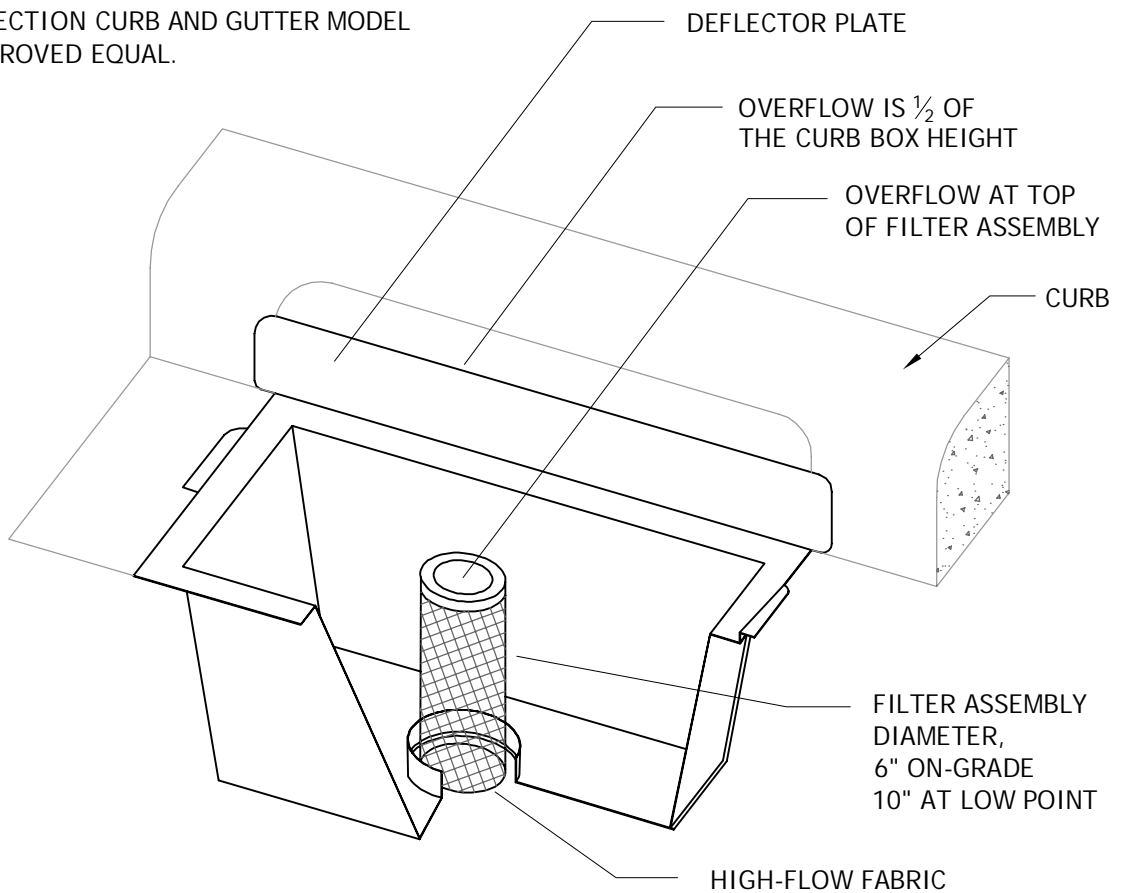

* FOR THE NEW R-3290-VB STANDARD CASTING,
INSTALL WIMCO ROAD DRAIN
CG-3290 OR CITY APPROVED EQUAL.



2335 Highway 36 W
St. Paul, MN 55113
www.stantec.com

INLET PROTECTION - CATCH BASIN INSERT AFTER CURB CONSTRUCTION

CHASKA, MINNESOTA

LAST REVISION:
APRIL 2008

PLATE NO.
ERO-4B

DEVICES TO BE INSTALLED IMMEDIATELY UPON INSTALLATION OF CONCRETE STRUCTURE CONE OR TOP SLAB.

DEVICES SHOWN ARE AS MANUFACTURED BY WIMCO. MODEL NO. OF UNIT SHOWN: RD 27.

OTHER APPROVED INLET PROTECTION DEVICES FOR BEEHIVE CASTINGS ARE:

- ROYAL ENTERPRISES - MODEL NO 27 INFRASAFE SEDIMENT CONTROL BARRIER - DG.
- PRE MANUFACTURED UNIT BY CIRCLE "H" ENTERPRISES.

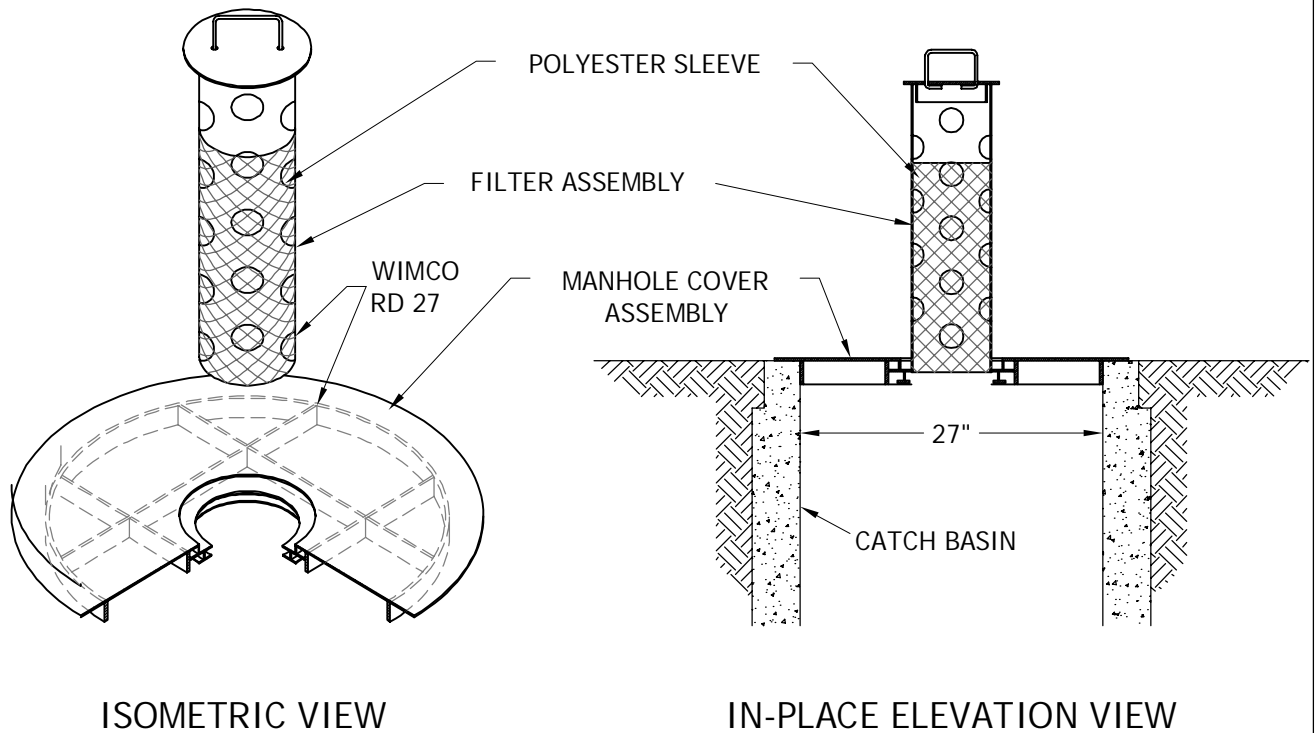

2335 Highway 36 W
St. Paul, MN 55113
www.stantec.com

INLET PROTECTION
BEEHIVE CASTING

CHASKA, MINNESOTA

LAST REVISION:
APRIL 2008

PLATE NO.
ERO-4C

DITCH CHECK SPACING

DITCH GRADE (%)	INTERVAL (FT)
2	100
4	75
6	50
8	40
10	25
10+	25

6" X 6" TRENCH WITH LEADING EDGE OF TYPE IV GEOTEXTILE FABRIC STAPLED AT 1' INTERVALS AND BACKFILLED WITH NATURAL SOIL

MnDOT 3733 GEOTEXTILE FABRIC

POINT 1

DITCH CHECK
ROCK/BIO WEEPER
OR CHECK DAM

POINT 2

MIN. 6" OVERLAP IF NECESSARY, STAPLE 1' O.C.

6" 11 GAUGE METAL STAPLES SPACED 2' O.C.

NOTE:
POINT 1 MUST BE A MINIMUM OF 6" HIGHER THAN POINT 2 TO ENSURE THAT WATER FLOWS OVER THE DITCH CHECK AND NOT AROUND THE ENDS.

	HEIGHT (INCHES)	WIDTH (INCHES)	MATERIAL
SMALL CHECK	24	12 - 18	MnDOT 3601 CLASS II RIP RAP
LARGE CHECK	36	24 - 30	MnDOT 3601 CLASS III RIP RAP
ROCK WEEPER	18	6 - 12	MnDOT 3882 TYPE 9 MULCH (1 1/2" WASHED ROCK)

ANCHOR TRENCH

1. DIG 6" X 6" TRENCH
2. LAY BLANKET IN TRENCH
3. STAPLE AT 1.5' INTERVALS
4. BACKFILL WITH NATURAL SOIL AND COMPACT

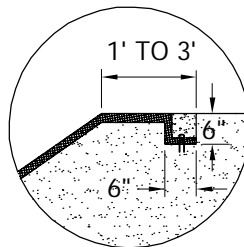

MATERIALS (SEE TABLE)

DIRECTION OF SURFACE FLOW

≥ 1.5

WIDTH (SEE TABLE)

HEIGHT (SEE TABLE)

TYPE IV GEOTEXTILE FABRIC ANCHORED IN 6" X 6" TRENCH WITH 6", 11 GAUGE METAL STAPLES AT 1' INTERVALS

STAPLE DOWNSTREAM SIDE OF FABRIC AT 2' INTERVALS



2335 Highway 36 W
St. Paul, MN 55113
www.stantec.com

DITCH CHECK / WEEPER SIZING AND MATERIALS

CHASKA, MINNESOTA

LAST REVISION:
APRIL 2008

PLATE NO.
ERO-5

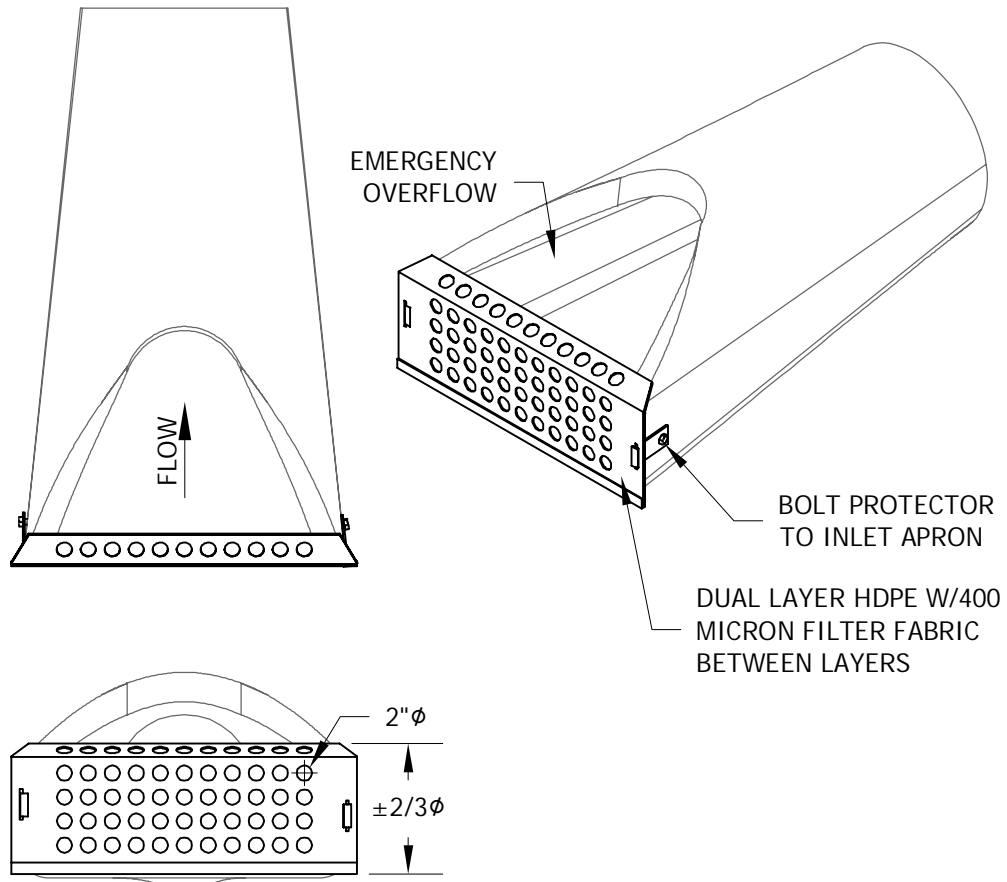

- FILTER FABRIC MAY BE REPLACED AS REQUIRED BY REMOVING BOLTS OR RIVETS CONNECTING HDPE LAYERS AND BOLTING OR RIVETING BACK TOGETHER.
- DEVICES SHOWN ARE AS MANUFACTURED BY ROYAL ENVIRONMENTAL SYSTEMS. INFRASAFE - CULVERT INLET PROTECTOR.



2335 Highway 36 W
St. Paul, MN 55113
www.stantec.com

FLARED END
EROSION CONTROL

CHASKA, MINNESOTA

LAST REVISION:
FEB 2005

PLATE NO.
ERO-6

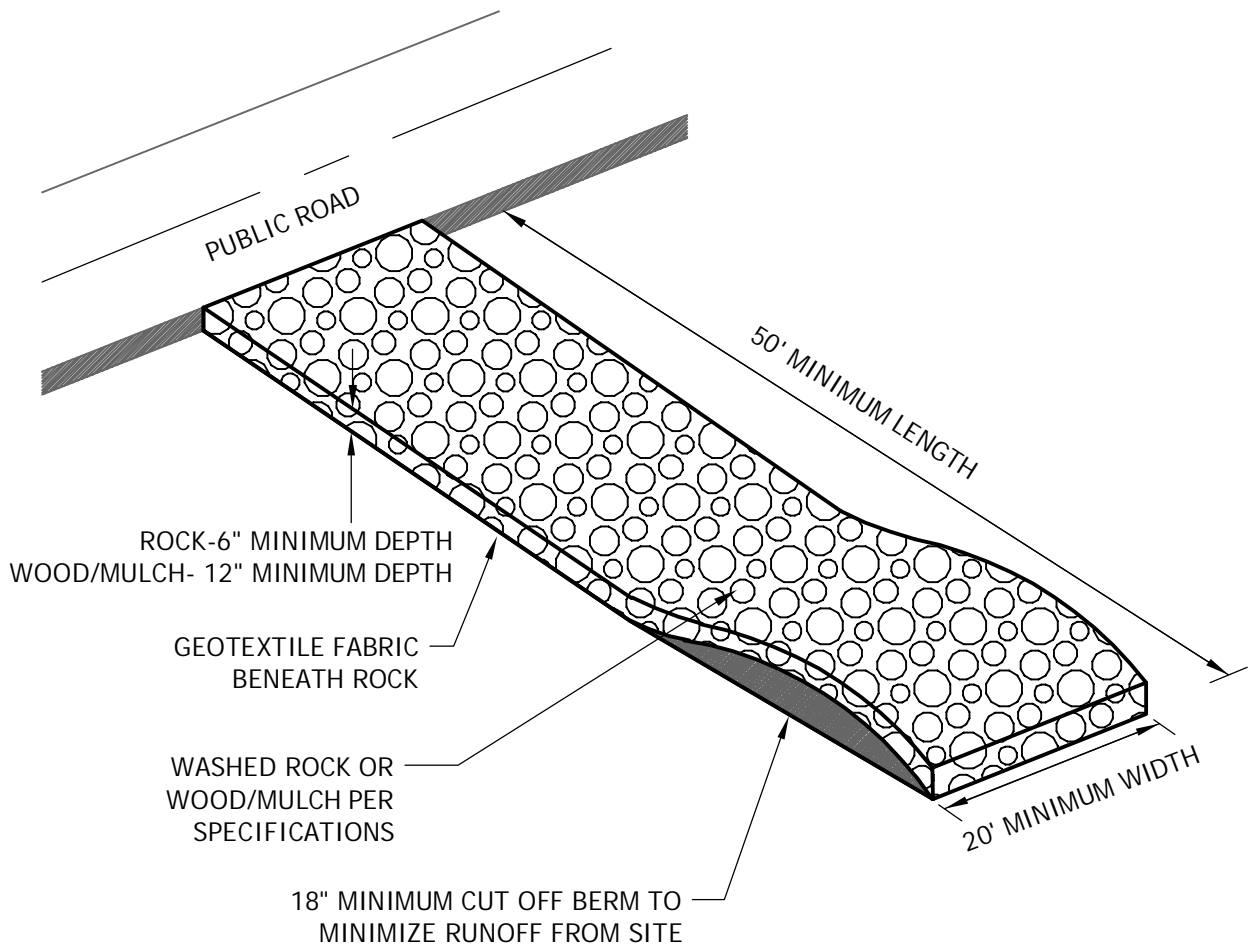

NOTES:

1. MnDOT 3733 TYPE 4 FILTER FABRIC SHALL BE PLACED UNDER ROCK OR MULCH TO STOP MUD MIGRATION THROUGH MATERIAL.
2. FUGITIVE ROCK OR MULCH WILL BE REMOVED FROM ADJACENT ROADWAYS DAILY OR MORE FREQUENTLY AS NECESSARY.
3. CONSTRUCTION ENTRANCE MUST BE CONSTRUCTED PRIOR TO THE COMMENCEMENT OF GRADING OPERATIONS ON THE SITE.
4. THE ENTRANCE MUST BE MAINTAINED IN PROPER CONDITION TO PREVENT TRACKING OF MUD OFF THE SITE. THIS MAY REQUIRE PERIODIC TOPDRESSING WITH ADDITIONAL ROCK, WOOD/MULCH, OR REMOVAL AND REINSTALLATION OF THE PAD.
5. THIS ENTRANCE WILL BE USED BY ALL VEHICLES ENTERING OR LEAVING THE PROJECT.
6. THE CONSTRUCTION ENTRANCE WILL BE REMOVED PRIOR TO THE PLACEMENT OF BITUMINOUS SURFACING.



2335 Highway 36 W
St. Paul, MN 55113
www.stantec.com

ROCK CONSTRUCTION ENTRANCE

CHASKA, MINNESOTA

LAST REVISION:
MAY 2023

PLATE NO.
ERO-7

I. PLAN VIEW

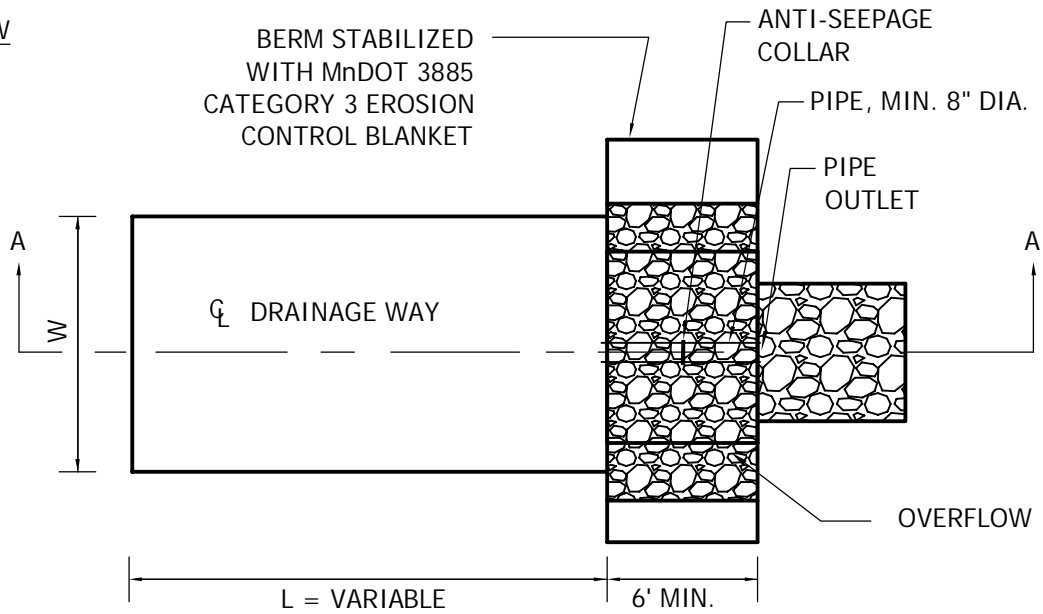

II. SECTION A-A

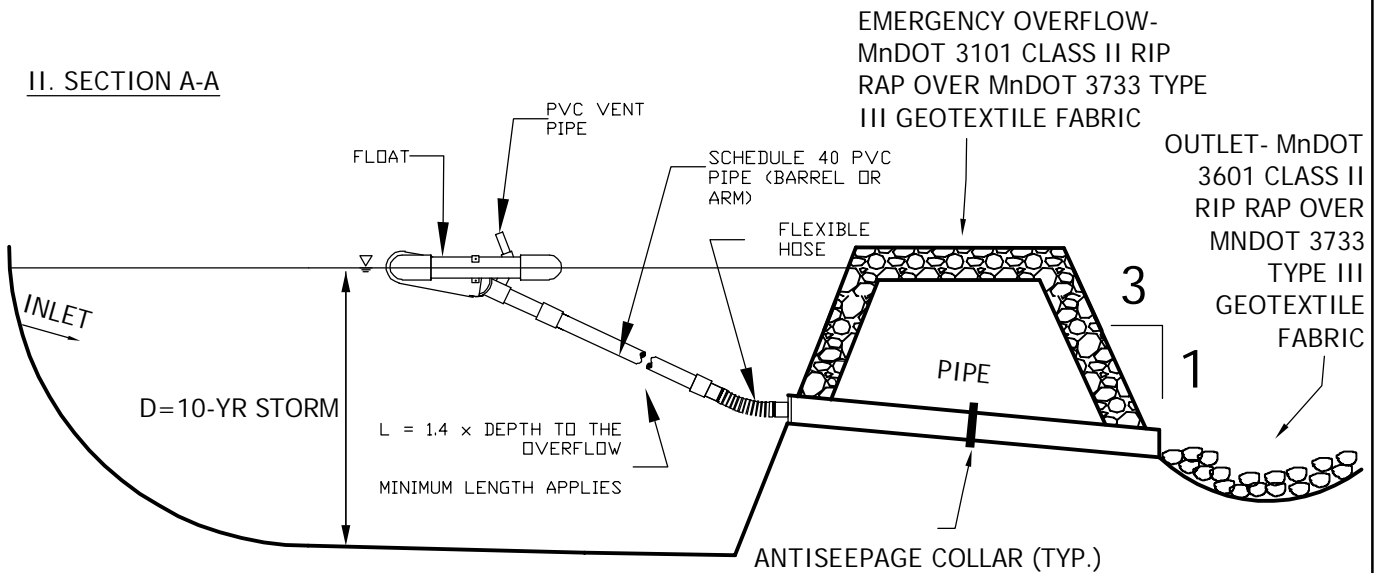

III. BASIN EMERGENCY OVERFLOW

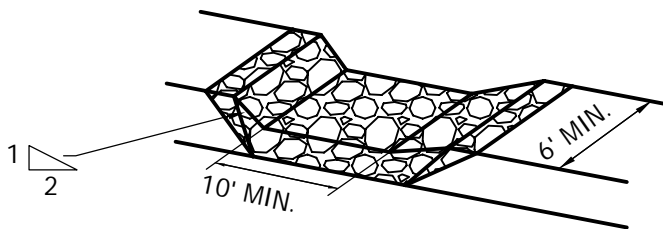

NOTES:

BASIN USED FOR 10 ACRES DRAINAGE AREA OR MORE.
 DESIGN RUNOFF VOLUME IS FROM A 2-YR, 24-HR STORM PER ACRE DRAINED TO THE BASIN. BASIN VOLUME MUST BE A MIN. OF 1800 CUBIC FEET/ACRE.
 SEE PLANS/SPECIFICATIONS FOR BASIN DIMENSIONS AND PIPE SIZE AND SLOPE.



2335 Highway 36 W
 St. Paul, MN 55113
 www.stantec.com

**TEMPORARY SEDIMENTATION BASIN
 SKIMMER OUTLET**

CHASKA, MINNESOTA

LAST REVISION:
 MAY 2023

PLATE NO.
ERO-8A

I. PLAN VIEW

NOTES:

BASIN USED FOR 10 ACRES
 DRAINAGE AREA OR MORE.
 DESIGN RUNOFF VOLUME IS
 FROM A 2-YR, 24-HR STORM
 PER ACRE DRAINED TO THE
 BASIN. BASIN VOLUME MUST
 BE A MIN. OF 1800 CUBIC
 FEET/ACRE.
 SEE PLANS/SPECIFICATIONS
 FOR BASIN DIMENSIONS AND
 PIPE SIZE AND SLOPE.

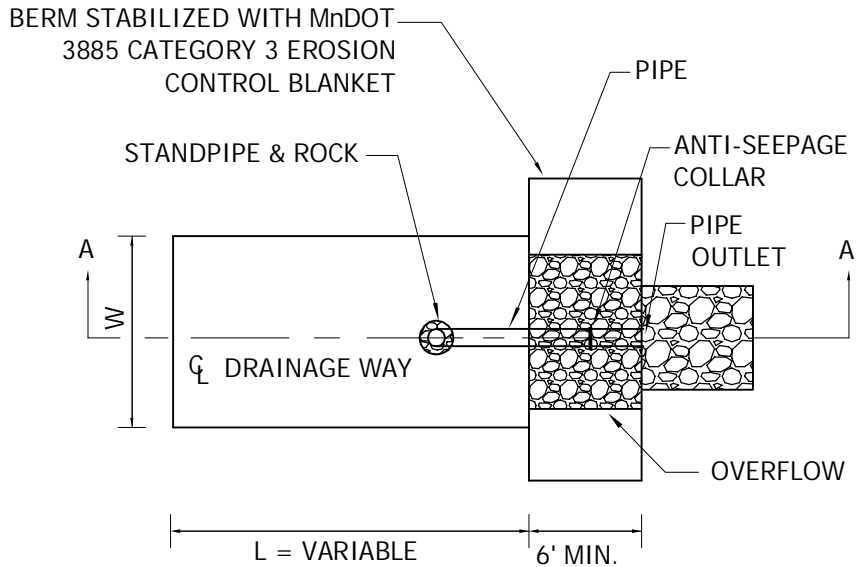

II. SECTION A-A

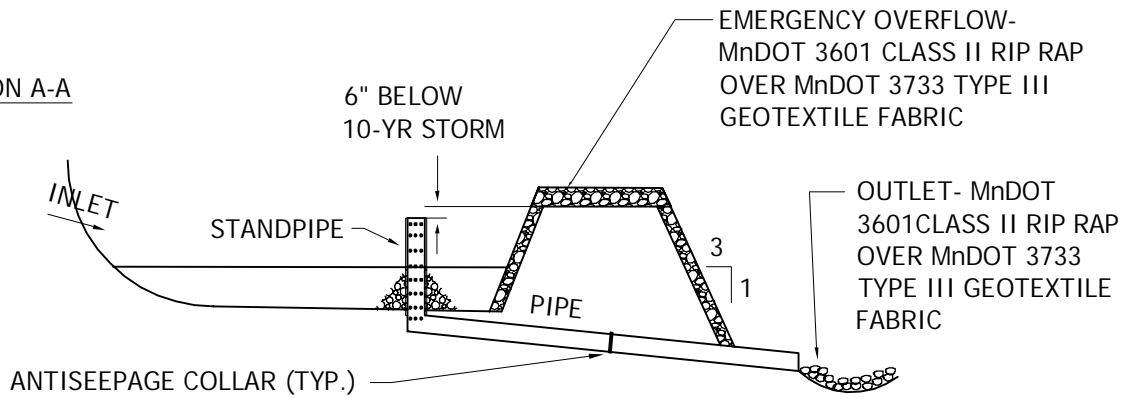

III. BASIN STANDPIPE AND EMERGENCY OVERFLOW

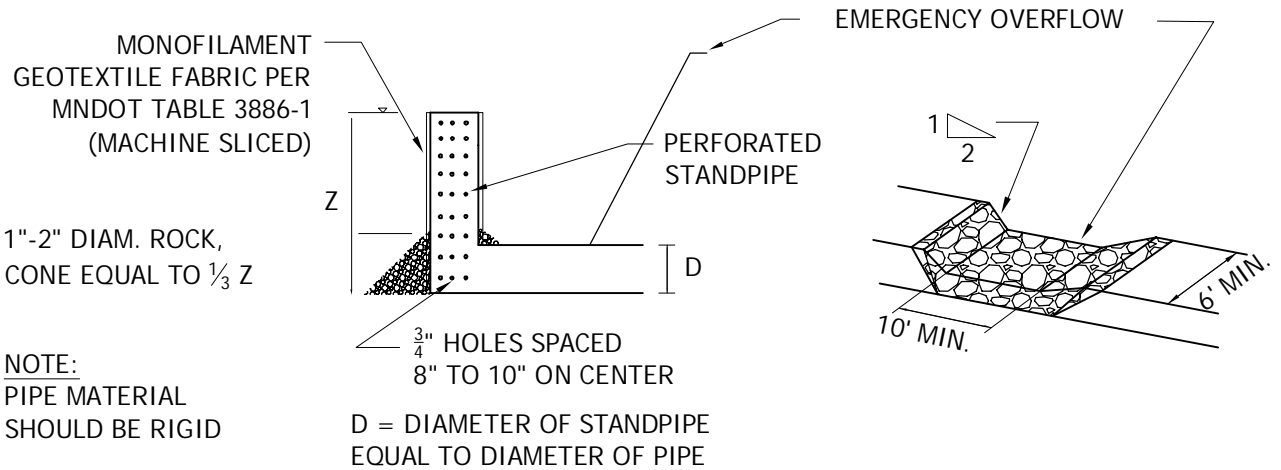

NOTE:
 PIPE MATERIAL
 SHOULD BE RIGID

D = DIAMETER OF STANDPIPE
 EQUAL TO DIAMETER OF PIPE



2335 Highway 36 W
 St. Paul, MN 55113
 www.stantec.com

**TEMPORARY SEDIMENTATION BASIN
 STANDPIPE OUTLET**

CHASKA, MINNESOTA

LAST REVISION:
 APRIL 2008

PLATE NO.
ERO-8B

I. PLAN VIEW

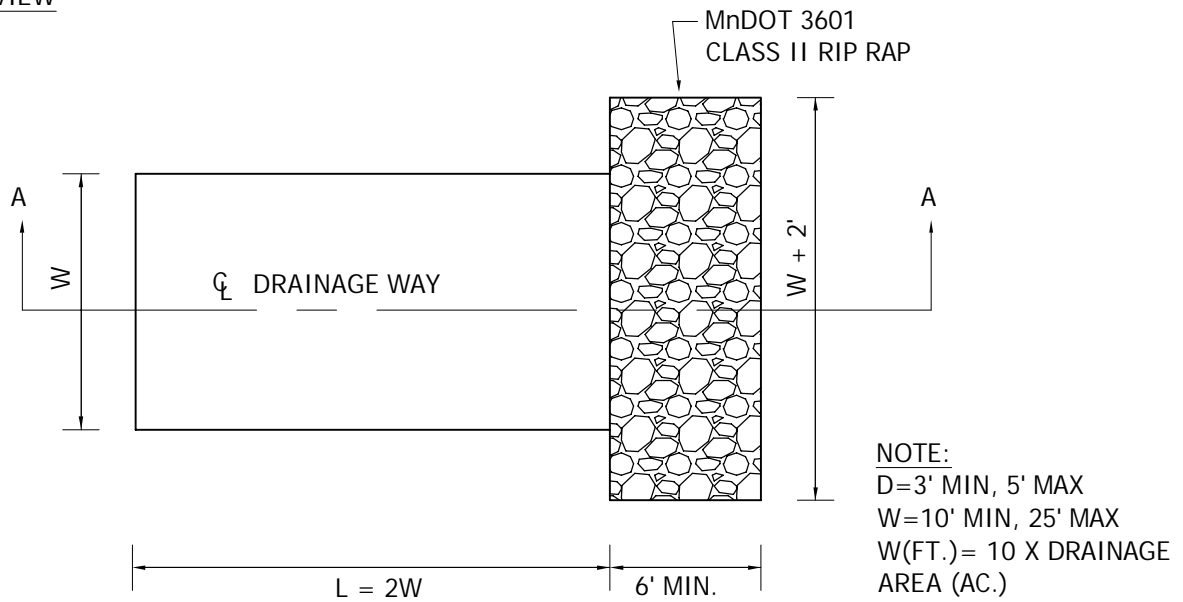

II. SECTION A-A

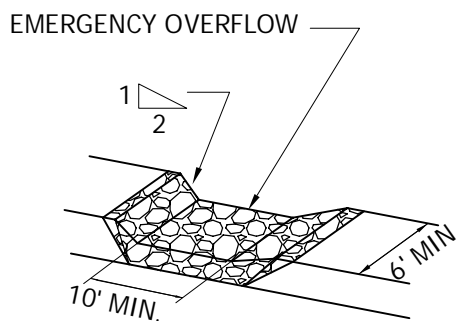
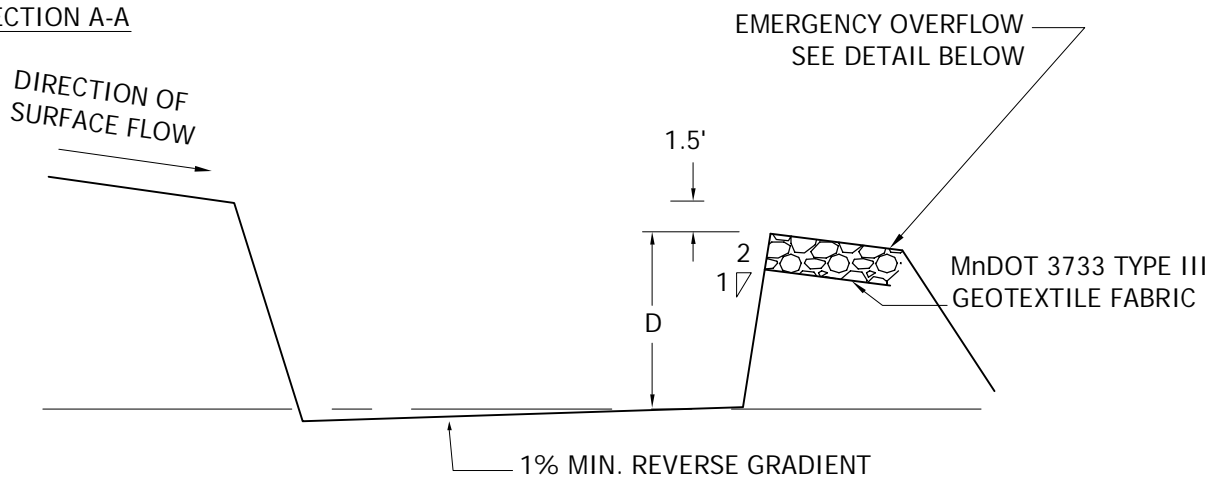

NOTES:
 TRAP USED FOR 2.5 ACRES
 DRAINAGE AREA OR LESS.
 DESIGN VOLUME IS A
 MINIMUM OF 1800 CUBIC
 FEET PER ACRE OF
 CONTRIBUTING DRAINAGE
 AREA.



2335 Highway 36 W
 St. Paul, MN 55113
 www.stantec.com

TEMPORARY SEDIMENT TRAP

CHASKA, MINNESOTA

LAST REVISION:
 APRIL 2008

PLATE NO.
 ERO-9

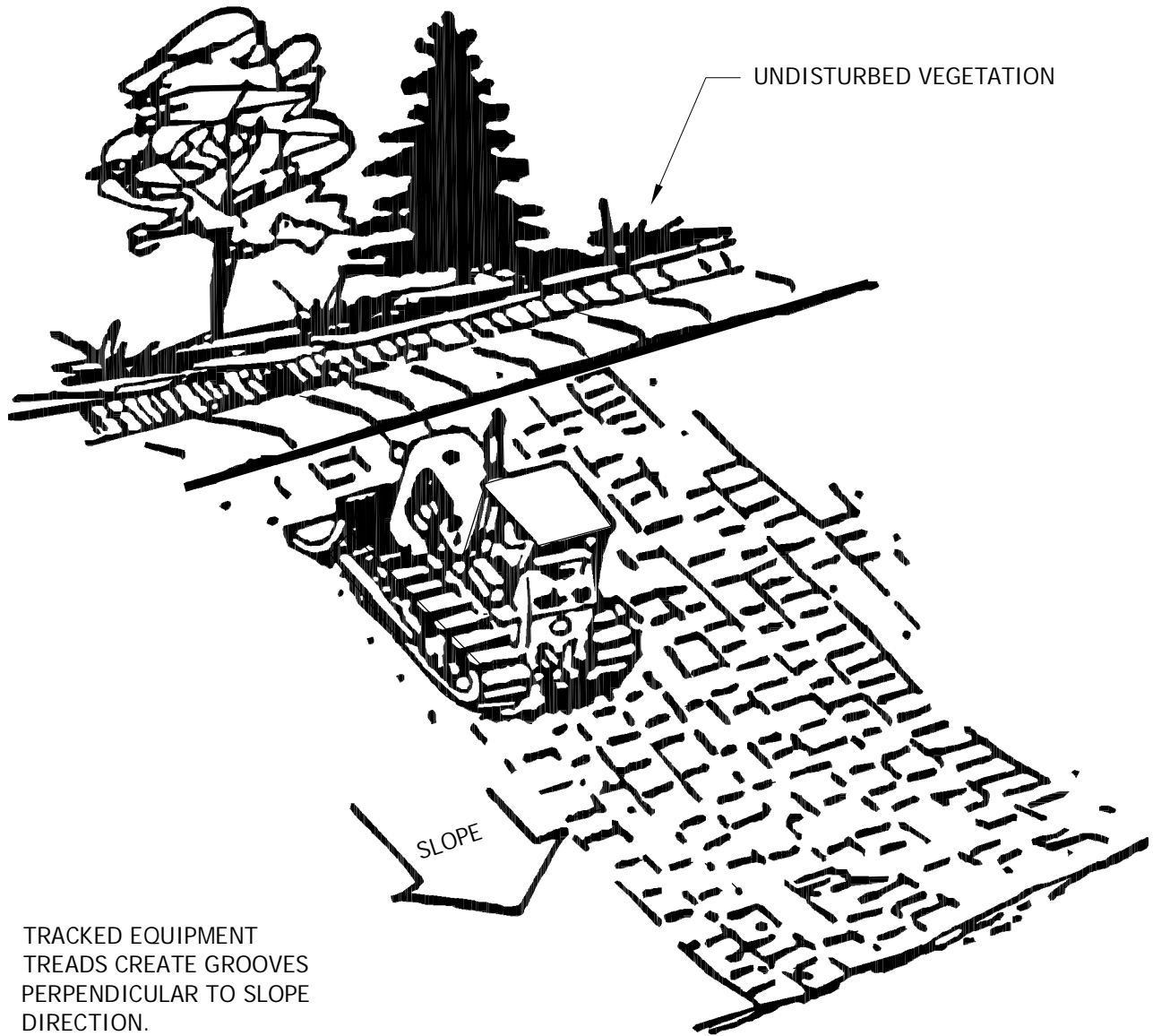

TRACKED EQUIPMENT
TRENDS CREATE GROOVES
PERPENDICULAR TO SLOPE
DIRECTION.

NOTE:

ALL SLOPES WITH A GRADE EQUAL TO OR STEEPER THAN 3:1
REQUIRE SLOPE TRACKING. SLOPES WITH A GRADE MORE GRADUAL
THAN 3:1 REQUIRE SLOPE TRACKING IF THE STABILIZATION METHOD
IS EROSION CONTROL BLANKET OR HYDROMULCH.



2335 Highway 36 W
St. Paul, MN 55113
www.stantec.com

SLOPE TRACKING
CHASKA, MINNESOTA

LAST REVISION:
FEB 2004

PLATE NO.
ERO-10

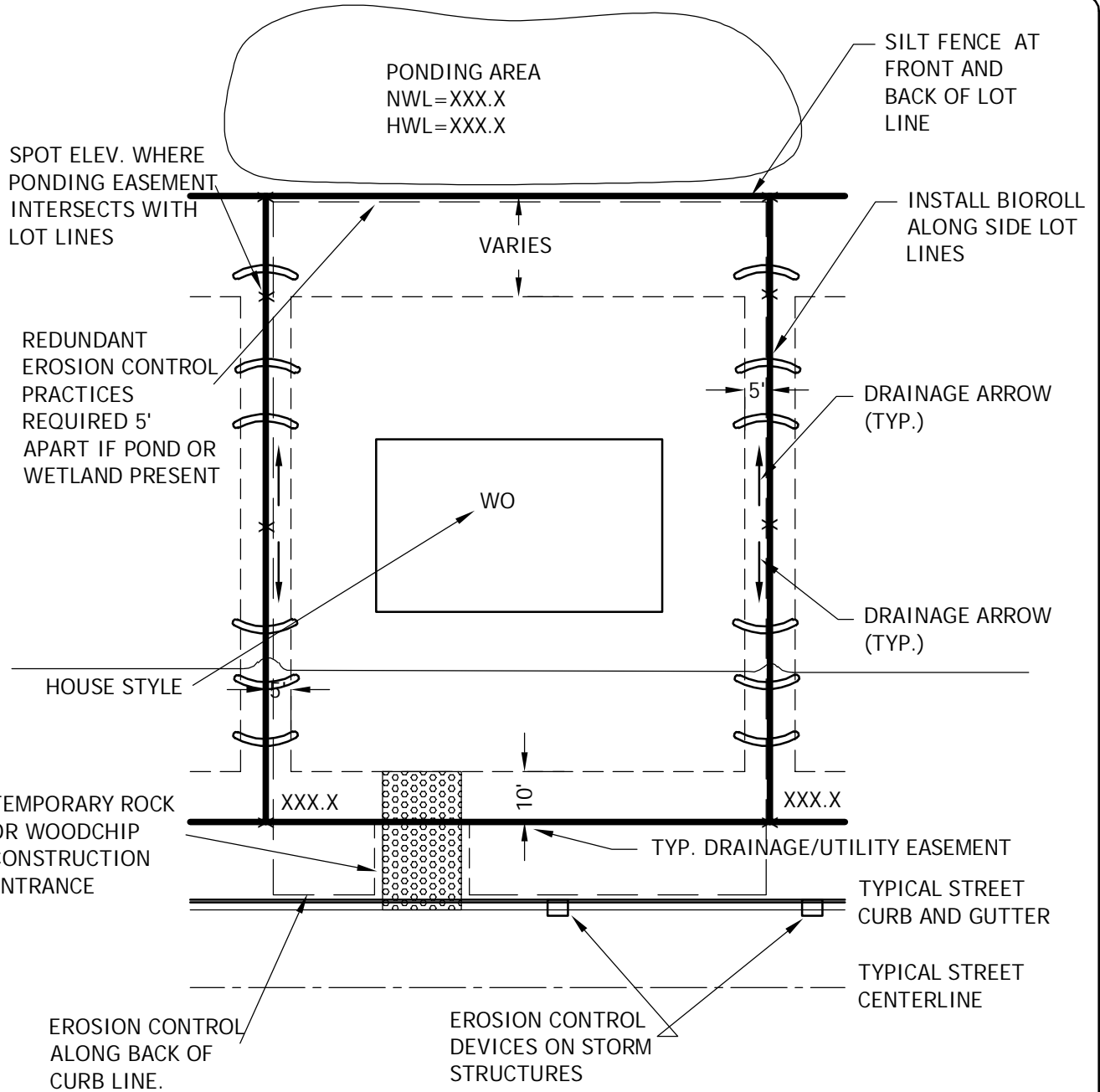

- 1.) INSTALL SILT FENCE PER DETAIL ERO-1A ALONG REAR AND SIDE PROPERTY LINES. INSTALL HEAVY DUTY SILT FENCE PER DETAIL ERO-1B ALONG BACK SIDE OF CURB.
- 2.) IF THERE IS A WETLAND OR PONDING AREA ADJACENT TO LOT, HEAVY DUTY SILT FENCE SHALL BE INSTALLED ALONG THAT SIDE OF LOT.
- 3.) CREATE ONE TEMPORARY CONSTRUCTION ENTRANCE PER LOT. SEE DETAIL ERO-7.
- 4.) INSTALL INLET PROTECTION ON ALL STORM STRUCTURES SUSCEPTIBLE TO RUNOFF FROM LOT. SEE DETAIL ERO-4B.

- 1) ALL WASHING OF CONCRETE TRUCKS WILL BE CONDUCTED AT THIS SITE.
- 2) ALL DIMENSIONS ARE APPROXIMATE AND MAY BE ADJUSTED BASED ON SITE CONSTRAINTS.
- 3) WHEN WASHOUT PIT IS NO LONGER NEEDED, SOLIDIFIED CONCRETE AND THE ROCK PAD WILL BE DISPOSED OF OFF-SITE AND THE AREA LEVELED OUT TO MATCH THE SURROUNDING GRADE.

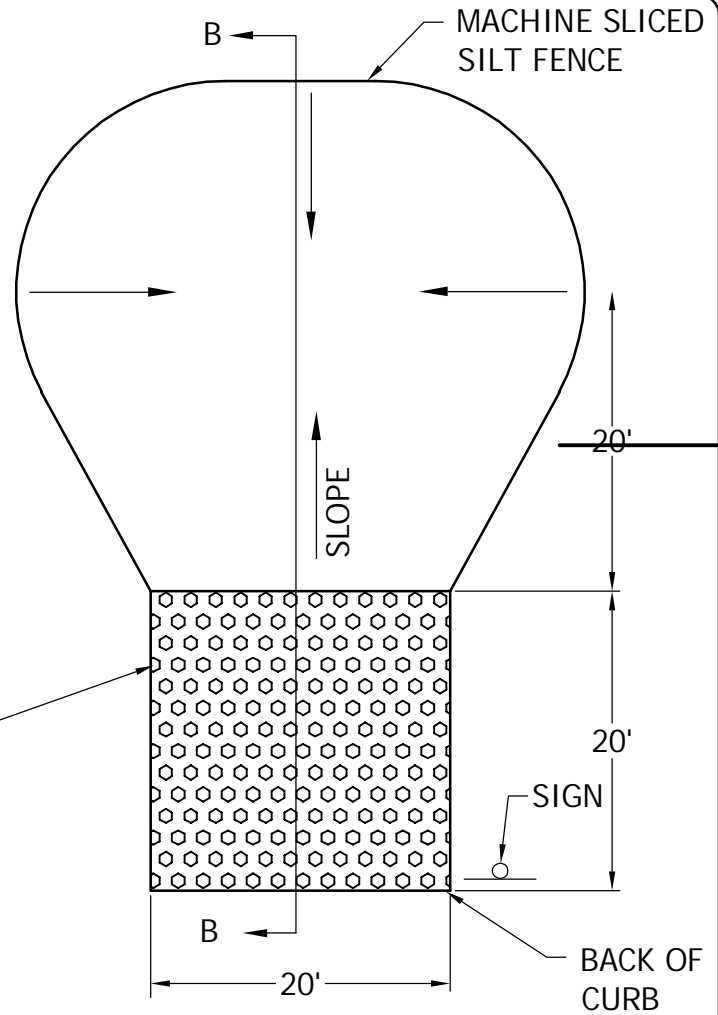

2" MINIMUM WASHED ROCK OR RAW WOOD/MULCH

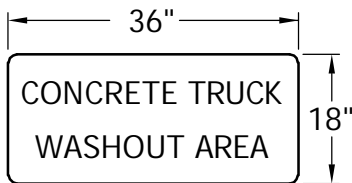

SIGN DETAIL

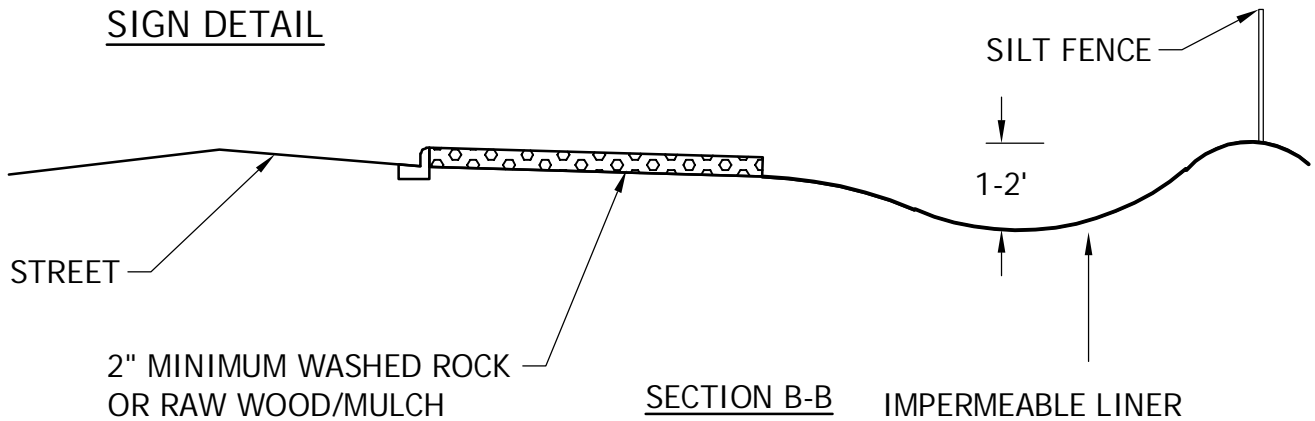

SECTION B-B

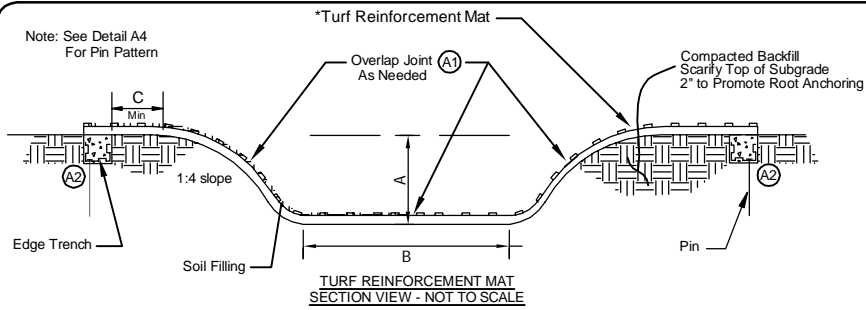

Description	TOP OF POND OVERFLOW	DOWN EMBANKMENT GRADE
A	Overflow Depth	1 FT
B	Overflow Width	20 FT
C	4:1 Slope to Edge of Trench	3 FT

*TURF REINFORCEMENT MAT PRODUCT TO BE LANDLOK 450, NORTH AMERICAN GREEN C350, OR APPROVED EQUAL

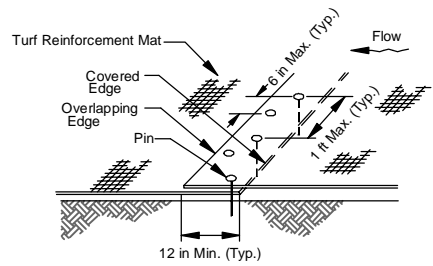

OVERLAP AT ROLL END DETAIL (A1)

*Note: Turf Reinforcement Mat Shingle/Overlap placement depends on down slope direction (i.e. Shingle in the direction of the down slope)

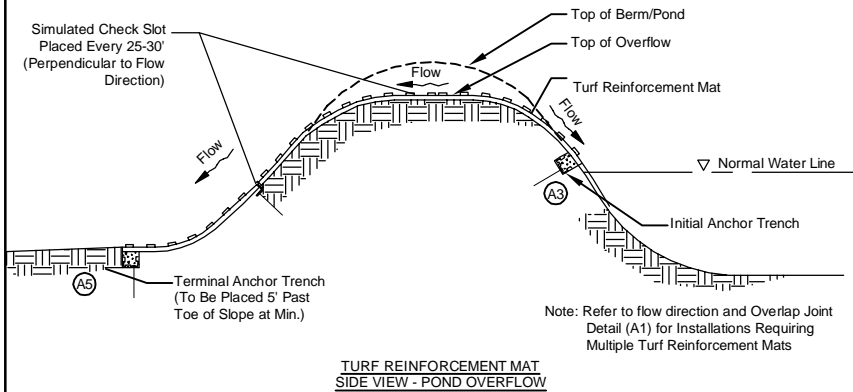

Note: Refer to flow direction and Overlap Joint Detail (A1) for Installations Requiring Multiple Turf Reinforcement Mats

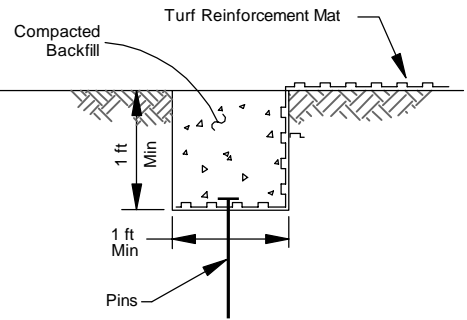

LONGITUDINAL EDGE TRENCH DETAIL (A2)

*Note: Pins in bottom of trench shall be placed 1 ft on center

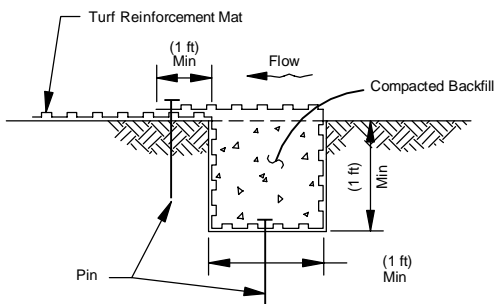

INITIAL ANCHOR TRENCH (UPSTREAM) DETAIL (A3)

*Note: Pins on bottom of trench and overlap shall be spaced 1 ft on center

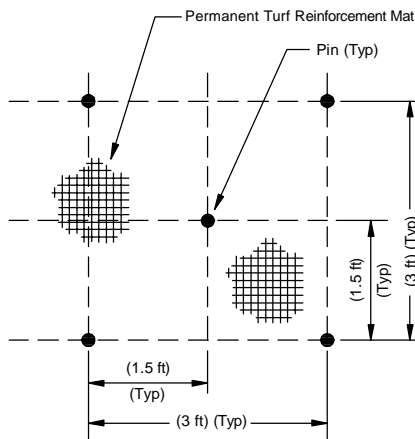

PIN PATTERN (A4)

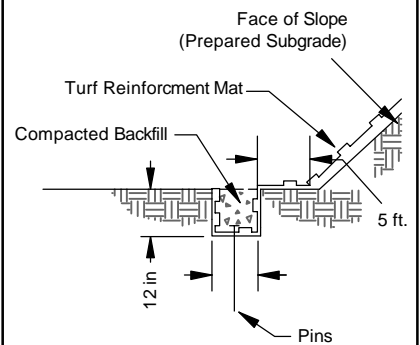

TERMINAL ANCHOR TRENCH AT TOE OF SLOPE DETAIL (A5)

*Note: Pins in bottom of trench shall be placed 1 ft on center



2335 Highway 36 W
 St. Paul, MN 55113
 www.stantec.com

TURF REINFORCEMENT MAT POND OVERFLOW

CHASKA, MINNESOTA

LAST REVISION:
 AUGUST 2023

PLATE NO.
 ERO-13

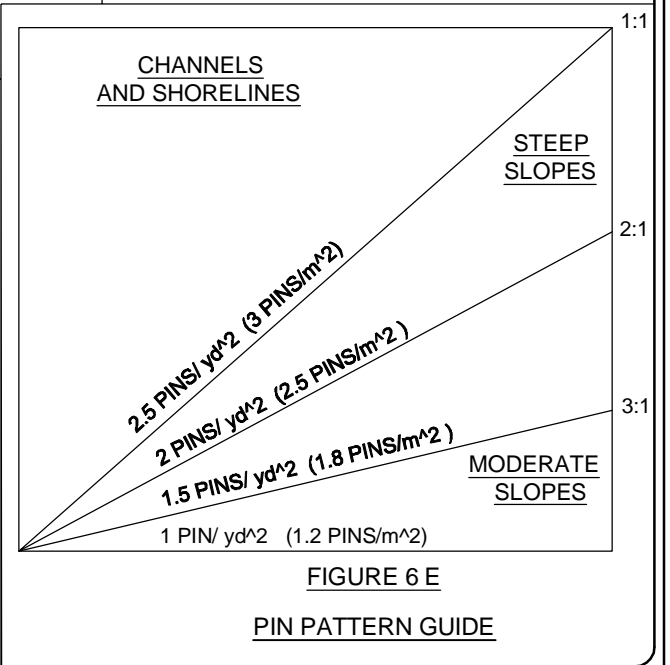
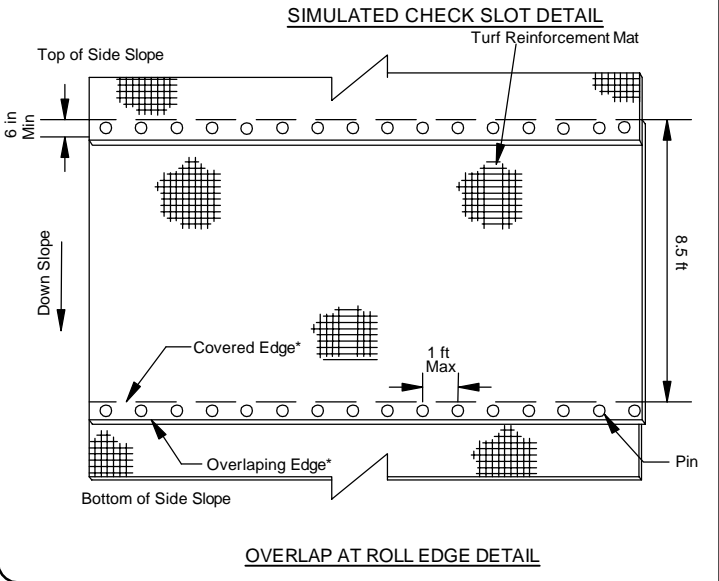
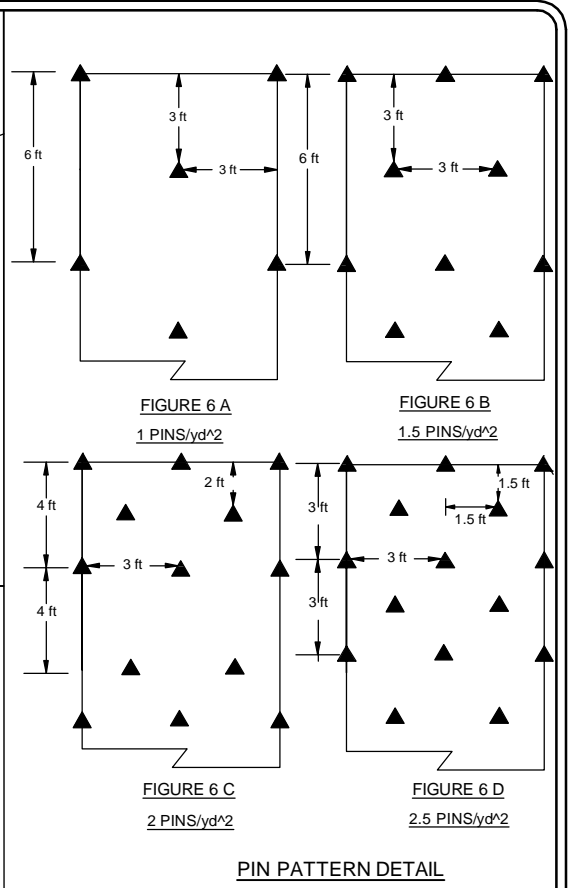
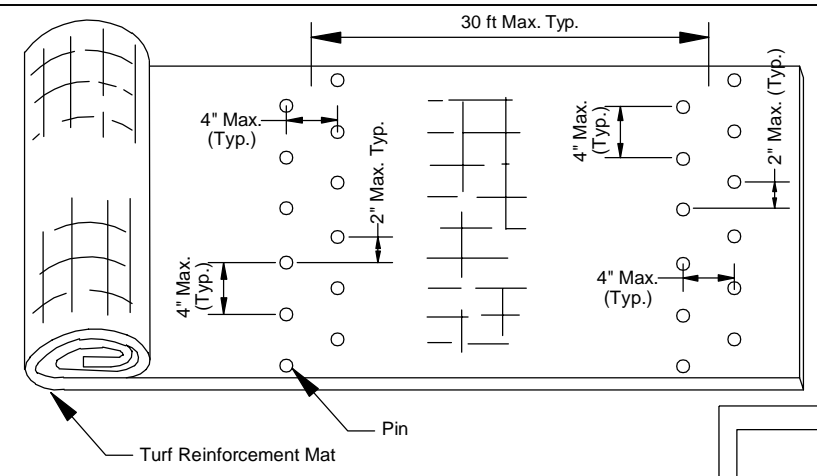
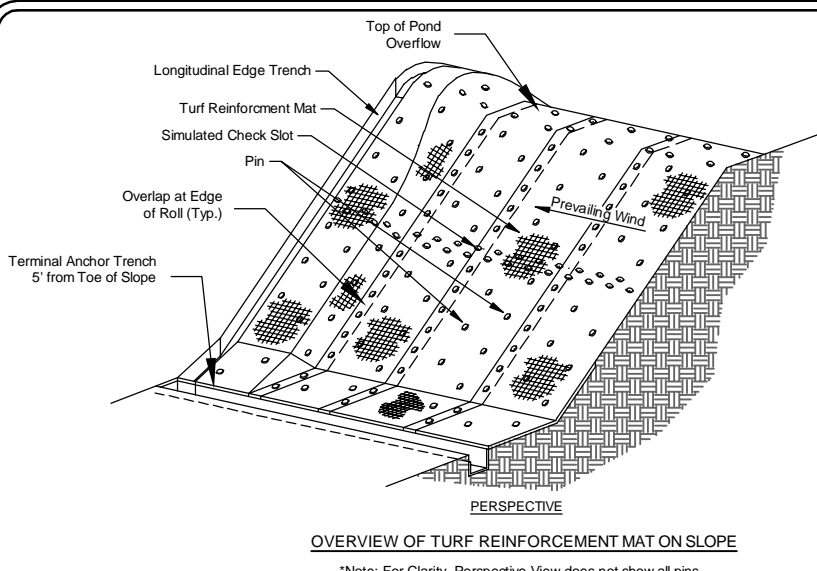

TURF REINFORCEMENT MAT ON SLOPE
CHASKA, MINNESOTA

LAST REVISION:
 MAY 2023

PLATE NO.
ERO-14

Plot Date: 05/25/2023
 Plot Name: \US0291\p08501\special\handdrawn\plan02 - Chaska\2323 Detail Plan\GRD-01.dwg
 Xref:

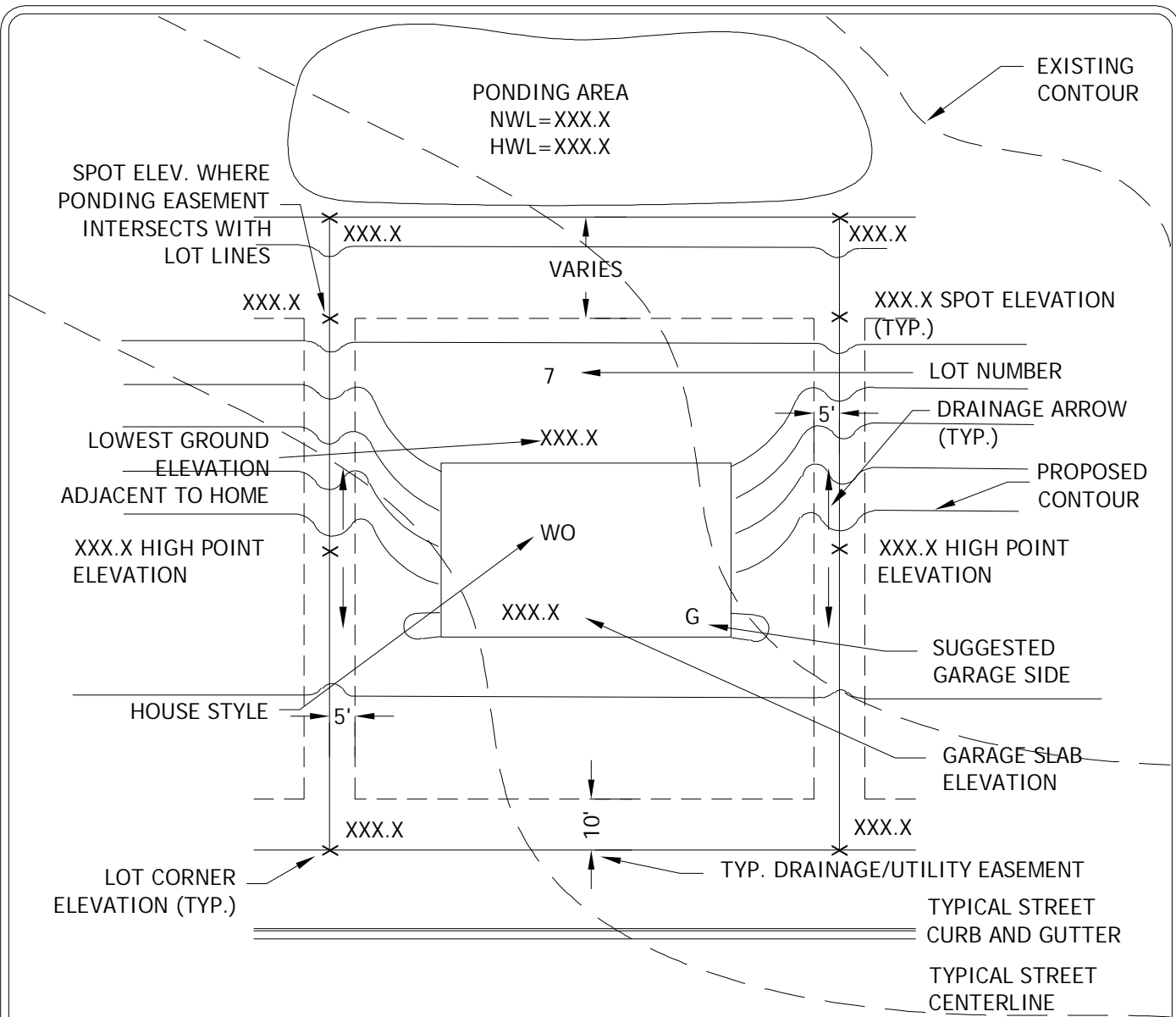

- 1.) GARAGE AND HOUSE ELEVATIONS SHALL BE WITHIN 1 FOOT OF THOSE NOTED ON THE APPROVED GRADING PLAN.
- 2.) EXISTING AND PROPOSED CONTOURS SHALL BE SHOWN AT 1 FOOT INTERVALS FOR ALL PROPOSED LOT GRADING WITH RETAINING WALLS AND DROP FOOTINGS SPECIFICALLY NOTED.
- 3.) SITE GRADING INFORMATION, INCLUDING EXISTING AND PROPOSED CONTOURS, SHALL BE SHOWN TO A DISTANCE OF 25' OUTSIDE PROPERTY.
- 4.) YARD GRADE SHALL HAVE A MINIMUM SLOPE OF 2% AND A MAXIMUM SLOPE OF 3:1
- 5.) DRIVEWAY GRADES TO HAVE A MIN SLOPE OF 2% AND A MAX GRADE OF 10%.
- 6.) HOUSE OPENINGS SHALL BE AT LEAST 2 FEET ABOVE SWALE BOTTOMS OR THE 100 YEAR HWL FOR ADJACENT WATER BODIES.



2335 Highway 36 W
 St. Paul, MN 55113
 www.stantec.com

REQUIRED LOT GRADING INFORMATION

CHASKA, MINNESOTA

LAST REVISION:
 MAY 2023

PLATE NO.
 GRD-1

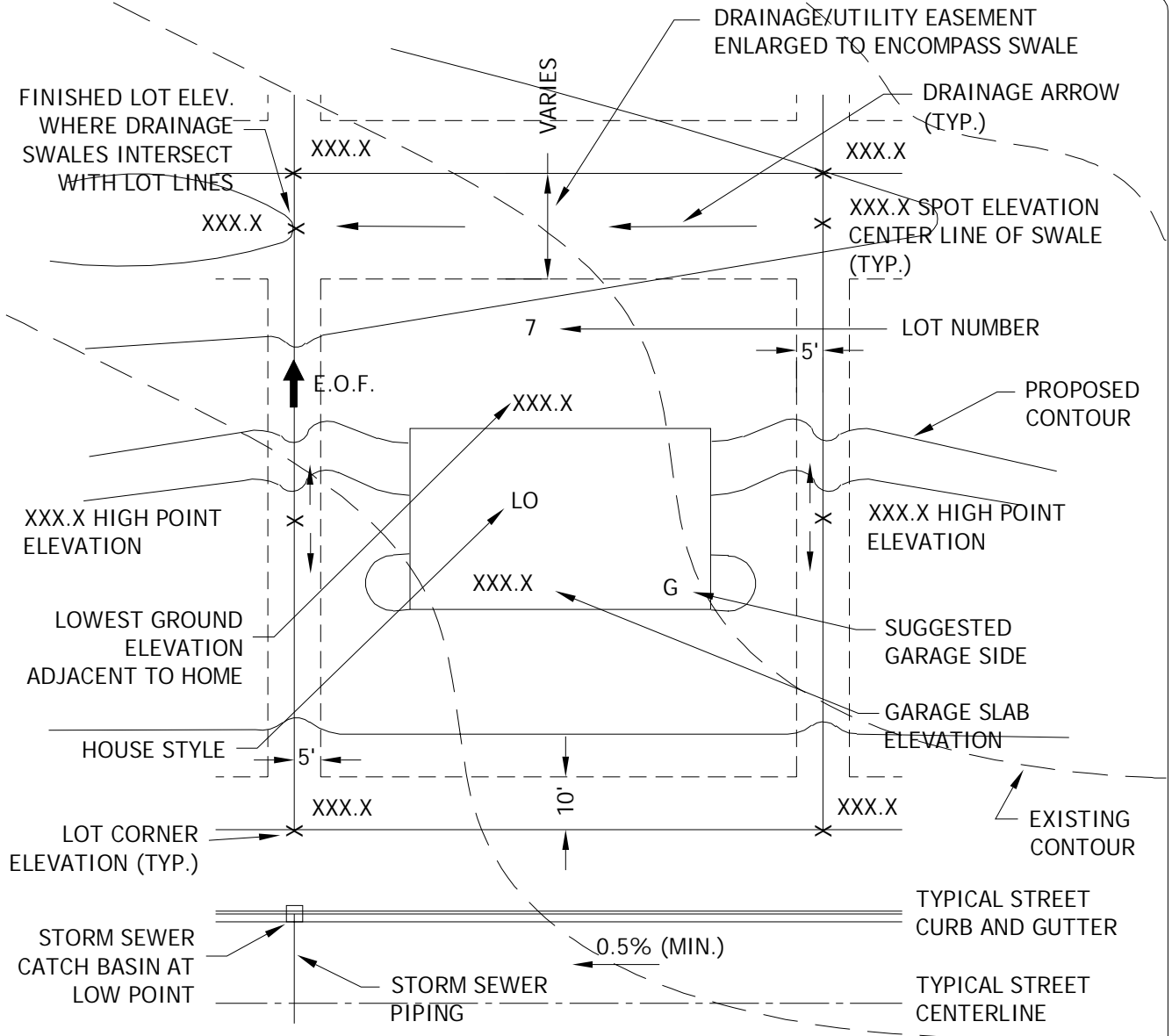

- 1.) GARAGE AND HOUSE ELEVATIONS SHALL BE WITHIN 1 FOOT OF THOSE NOTED ON THE APPROVED GRADING PLAN.
- 2.) EXISTING AND PROPOSED CONTOURS SHALL BE SHOWN AT 1 FOOT INTERVALS FOR ALL PROPOSED LOT GRADING WITH RETAINING WALLS AND DROP FOOTINGS SPECIFICALLY NOTED.
- 3.) SITE GRADING INFORMATION, INCLUDING EXISTING AND PROPOSED CONTOURS, SHALL BE SHOWN TO A DISTANCE OF 25' OUTSIDE PROPERTY.
- 4.) YARD GRADE SHALL HAVE A MINIMUM SLOPE OF 2% AND A MAXIMUM SLOPE OF 3:1.
- 5.) DRIVEWAY GRADES TO HAVE A MIN SLOPE OF 2% AND A MAX GRADE OF 10%.
- 6.) HOUSE OPENINGS SHALL BE AT LEAST 2 FEET ABOVE SWALE BOTTOMS OR THE 100 YEAR HWL FOR ADJACENT WATER BODIES.



2335 Highway 36 W
 St. Paul, MN 55113
 www.stantec.com

REQUIRED LOT GRADING INFORMATION

CHASKA, MINNESOTA

LAST REVISION:
 MAY 2023

PLATE NO.
 GRD-2

Plot Date: 05/25/2023
 Plotting name: \\s01291\p016501\special\handdrawn\planets2 - Chaska\2323 Detail\PlanetsGRD-03.dwg
 Xref:

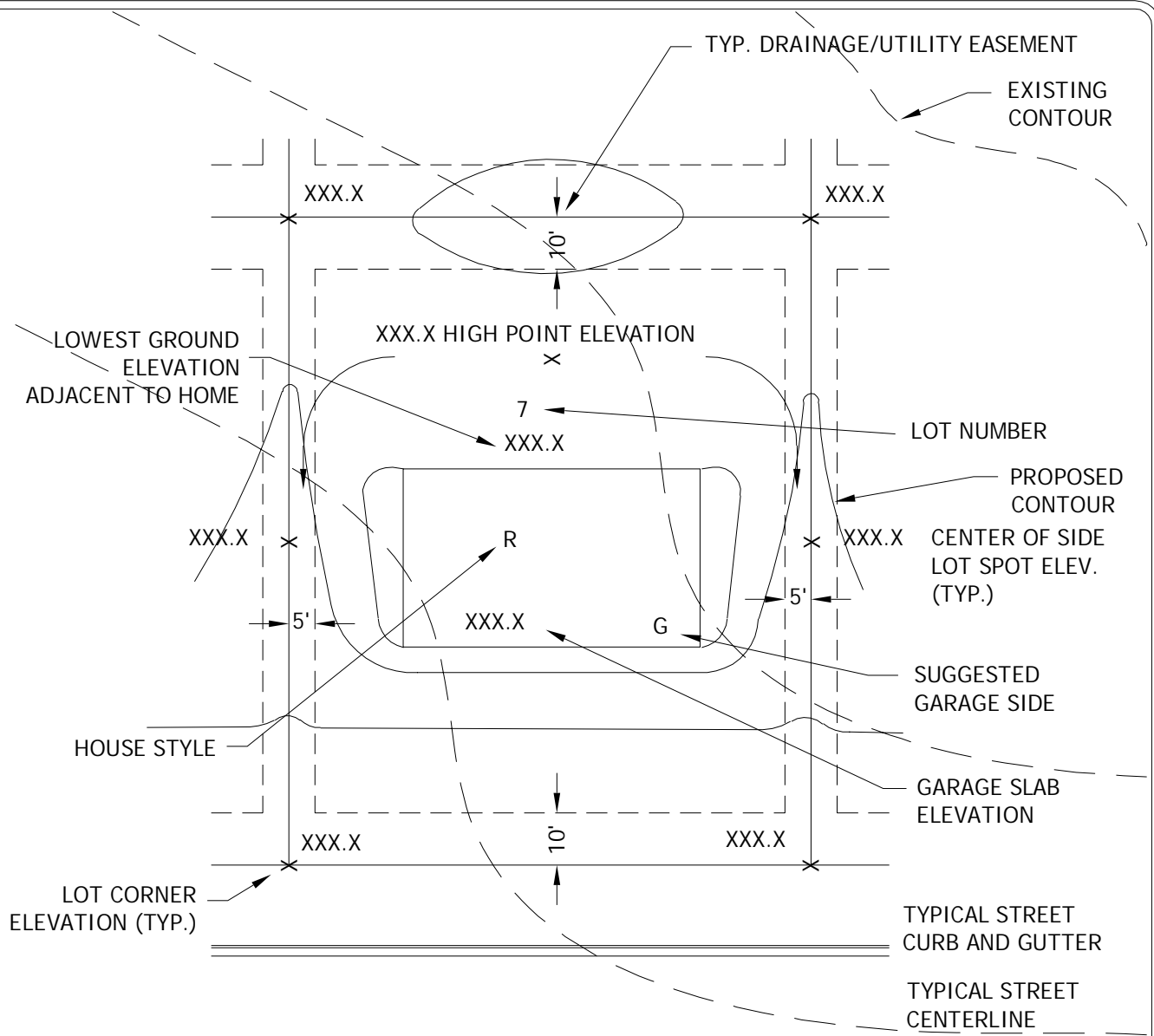

- 1.) GARAGE AND HOUSE ELEVATIONS SHALL BE WITHIN 1 FOOT OF THOSE NOTED ON THE APPROVED GRADING PLAN.
- 2.) EXISTING AND PROPOSED CONTOURS SHALL BE SHOWN AT 1 FOOT INTERVALS FOR ALL PROPOSED LOT GRADING WITH RETAINING WALLS AND DROP FOOTINGS SPECIFICALLY NOTED.
- 3.) SITE GRADING INFORMATION, INCLUDING EXISTING AND PROPOSED CONTOURS, SHALL BE SHOWN TO A DISTANCE OF 25' OUTSIDE PROPERTY.
- 4.) YARD GRADE SHALL HAVE A MINIMUM SLOPE OF 2% AND A MAXIMUM SLOPE OF 3:1.
- 5.) DRIVEWAY GRADES TO HAVE A MIN SLOPE OF 2% AND A MAX GRADE OF 10%.
- 6.) HOUSE OPENINGS SHALL BE AT LEAST 2 FEET ABOVE SWALE BOTTOMS OR THE 100 YEAR HWL FOR ADJACENT WATER BODIES.



2335 Highway 36 W
 St. Paul, MN 55113
 www.stantec.com

REQUIRED LOT GRADING INFORMATION

CHASKA, MINNESOTA

LAST REVISION:
 MAY 2023

PLATE NO.
 GRD-3

Plot Date: 05/25/2023
 Plotting Name: \\js0291\ps01\special\handdrawn\plans\02_Chaska\4.22.23_Detail_Planes\GRD-04.dwg
 Xref:

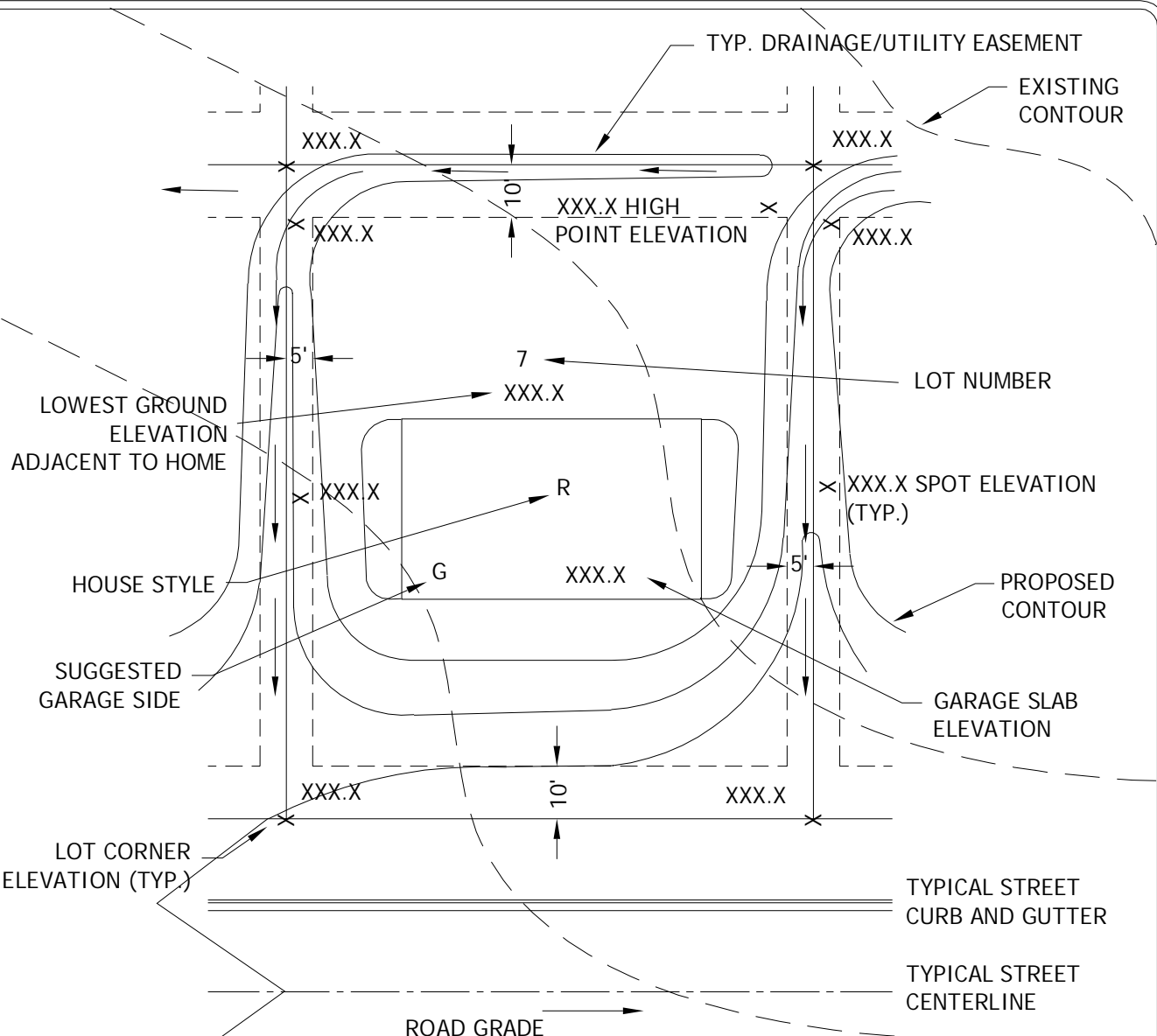

- 1.) GARAGE AND HOUSE ELEVATIONS SHALL BE WITHIN 1 FOOT OF THOSE NOTED ON THE APPROVED GRADING PLAN.
- 2.) EXISTING AND PROPOSED CONTOURS SHALL BE SHOWN AT 1 FOOT INTERVALS FOR ALL PROPOSED LOT GRADING WITH RETAINING WALLS AND DROP FOOTINGS SPECIFICALLY NOTED.
- 3.) SITE GRADING INFORMATION, INCLUDING EXISTING AND PROPOSED CONTOURS, SHALL BE SHOWN TO A DISTANCE OF 25' OUTSIDE PROPERTY.
- 4.) YARD GRADE SHALL HAVE A MINIMUM SLOPE OF 2% AND A MAXIMUM SLOPE OF 3:1.
- 5.) DRIVEWAY GRADES TO HAVE A MIN SLOPE OF 2% AND A MAX GRADE OF 10%.
- 6.) HOUSE OPENINGS SHALL BE AT LEAST 2 FEET ABOVE SWALE BOTTOMS OR THE 100 YEAR HWL FOR ADJACENT WATER BODIES.



REQUIRED LOT GRADING INFORMATION

CHASKA, MINNESOTA

LAST REVISION:
 MAY 2023

PLATE NO.
GRD-4

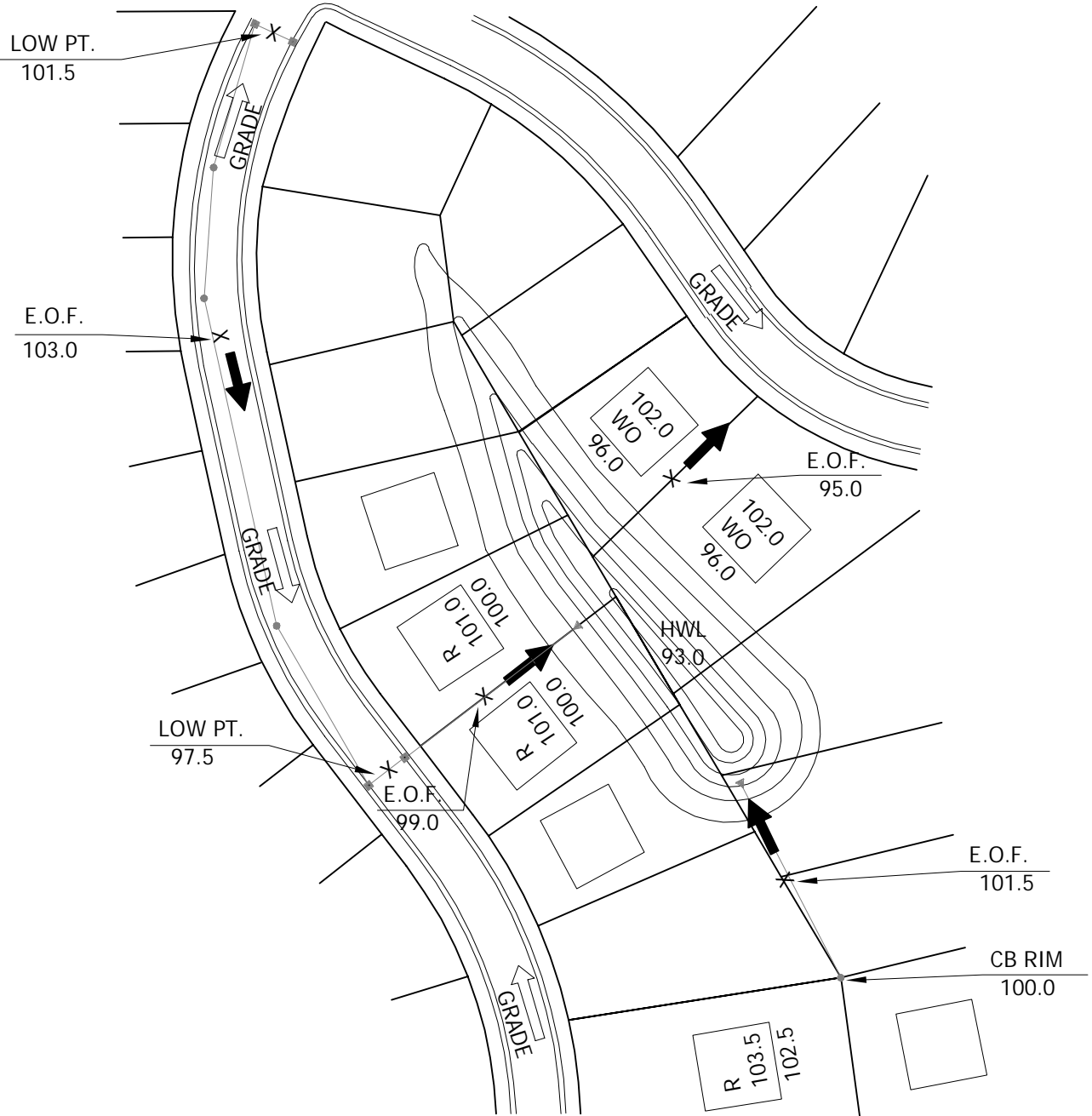

NOTE: EMERGENCY OVERFLOW HIGH POINT ELEVATIONS AND DIRECTIONS OF FLOW MUST BE SHOWN FOR ALL STREET AND REAR YARD CATCH BASINS, PONDS, LAKES, WETLANDS, DITCHES AND STREAMS. A MINIMUM ONE FOOT (1') SEPARATION MUST BE MAINTAINED BETWEEN E.O.F. HIGH POINTS AND THE LOWEST GROUND ELEVATION ADJACENT TO SURROUNDING HOMES OR BUILDINGS. A MAXIMUM 18" SEPARATION MUST BE MAINTAINED BETWEEN THE STREET CENTERLINE LOWPOINT ELEVATION AND THE E.O.F. HIGH POINT. ALL SIDE AND REAR LOT SWALES MUST HAVE A MINIMUM SLOPE OF 2%.



2335 Highway 36 W
 St. Paul, MN 55113
 www.stantec.com

EMERGENCY OVERFLOW DETAIL

CHASKA, MINNESOTA

LAST REVISION:
 MARCH 2001

PLATE NO.
 GRD-5

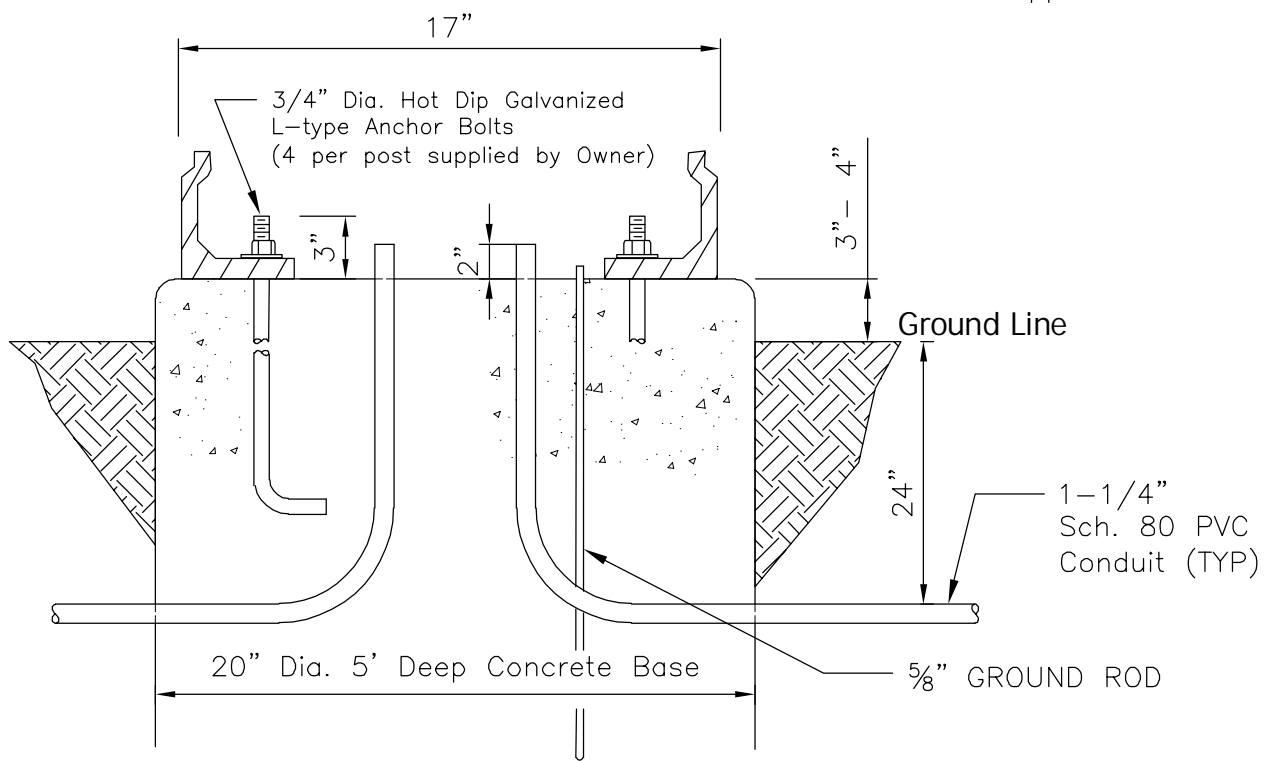
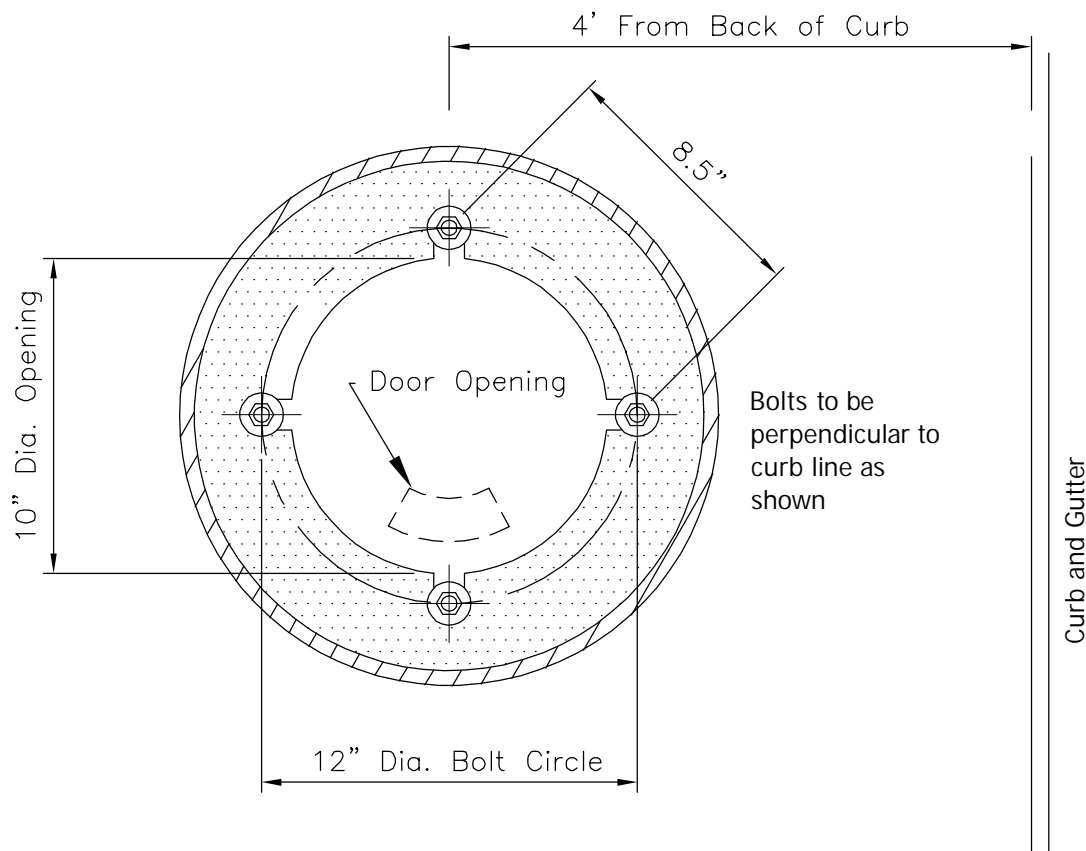

2335 Highway 36 W
St. Paul, MN 55113
www.stantec.com

LIGHT POLE
ANCHORAGE GUIDE
AND LOCATION

CHASKA, MINNESOTA

LAST REVISION:
JAN 2019

PLATE NO.
ELC-01

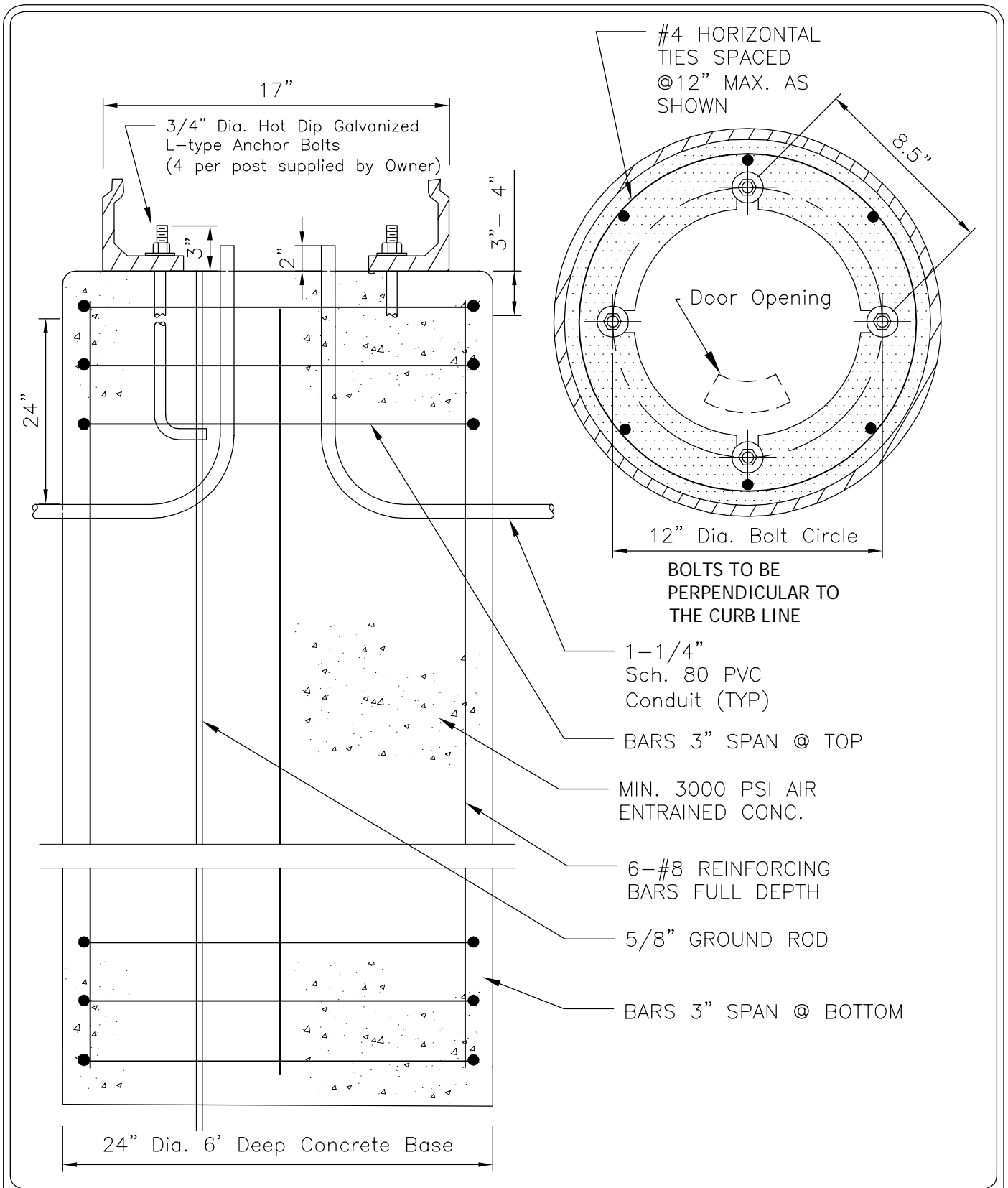

2335 Highway 36 W
St. Paul, MN 55113
www.stantec.com

BANNER POLE ANCHORAGE GUIDE

CHASKA, MINNESOTA

LAST REVISION:
APRIL 2017

PLATE NO.
ELC-01A

STATION DATA	
PUMP CAPACITY (EACH)	GPM
PUMP HEAD (TDH)	FEET
MOTOR HORSEPOWER	HP
MOTOR SPEED	RPM
ELECTRICAL SERVICE	VOLT , PHASE ,HZ
SECONDARY SERVICE	CONDUIT & WIRE SIZE
DISCONNECT SIZE	AMP

- NOTES:**
1. PIPE AND FITTINGS INSIDE STRUCTURES SHALL BE FLANGED.
 2. WET WELL MUST BE SIZED AND DESIGNED.
 3. VALVE VAULT MUST BE SIZED.
 4. INLET AND DISCHARGE PIPING, VALVES AND FITTINGS MUST BE SIZED.
 5. HATCHES MUST BE SIZED.
 6. SECONDARY ELECTRICAL SERVICE MUST BE SIZED.
 7. PUMP STATION DATA TABLE ABOVE MUST BE COMPLETED.
 8. SITE TO PROVIDE ADEQUATE ACCESS AND STABILITY.

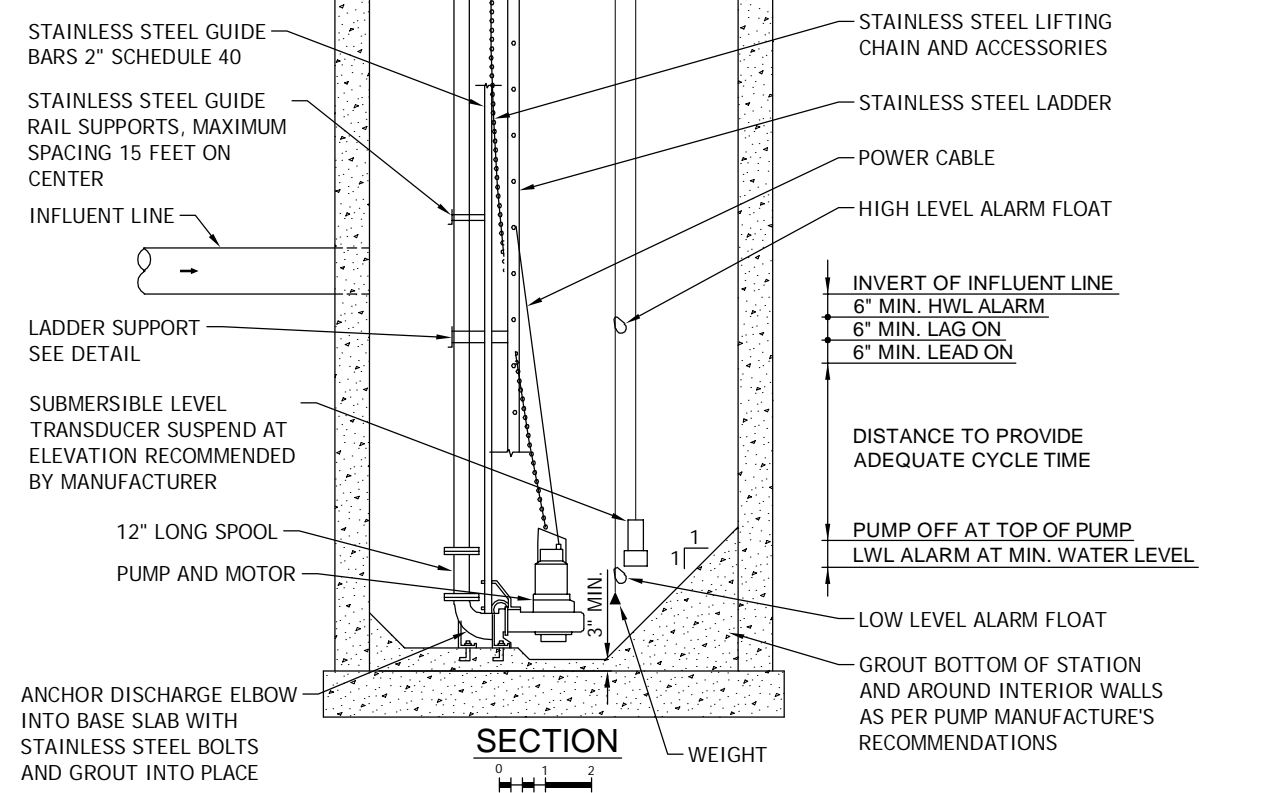
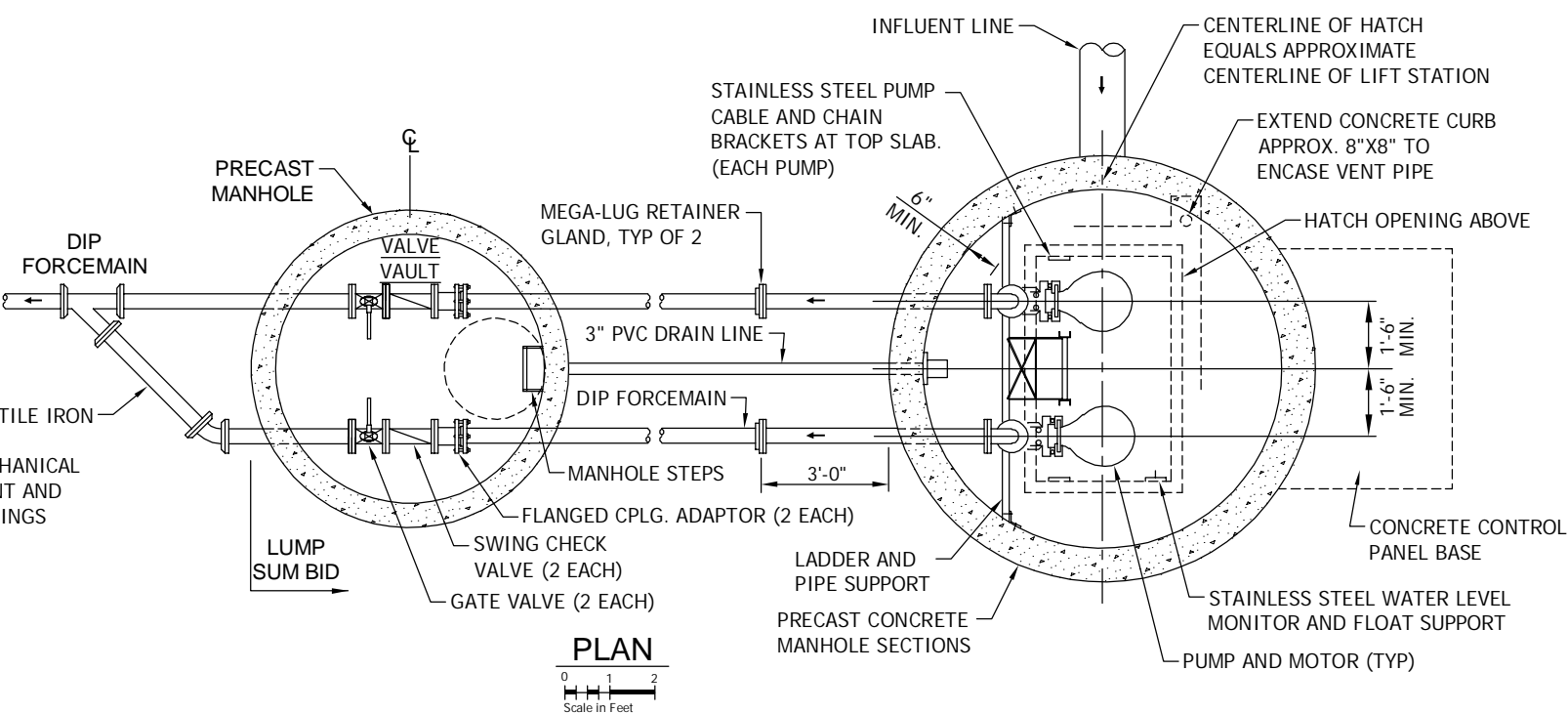
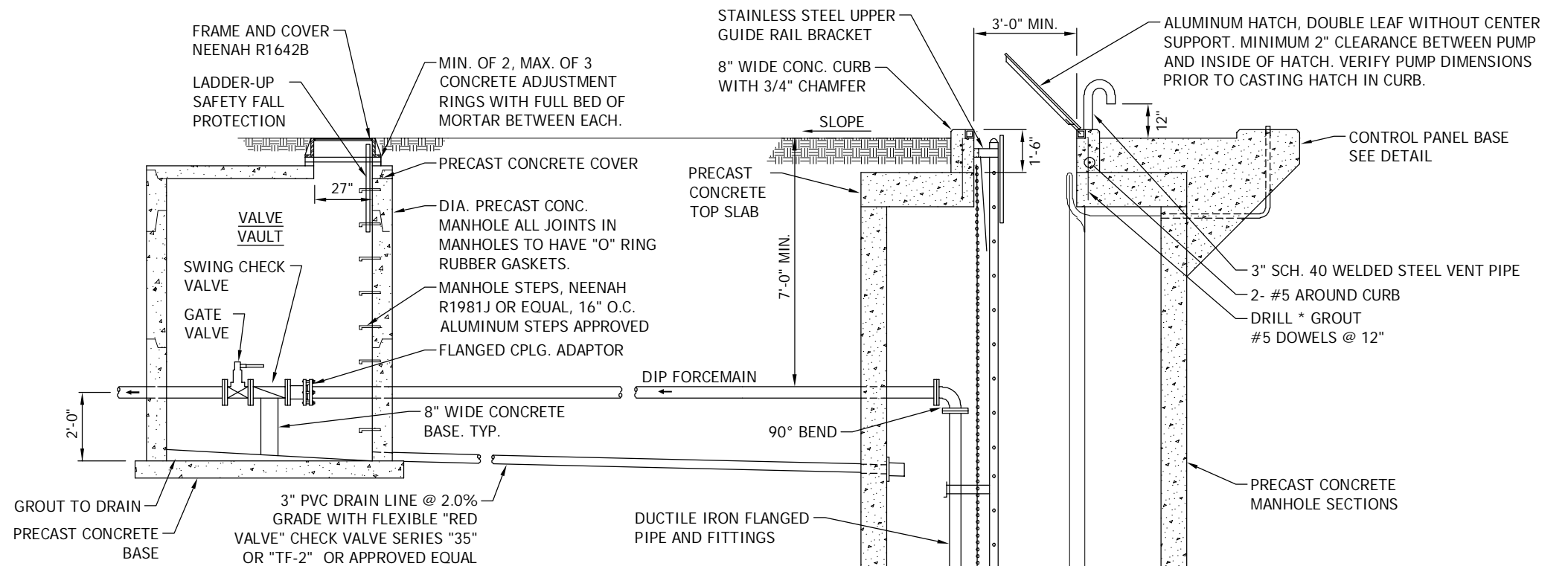

WASTEWATER PUMPING STATION MISCELLANEOUS DETAILS

CHASKA, MINNESOTA



2335 Highway 36 W
St. Paul, MN 55113
www.stantec.com

LAST REVISION:
JUNE 2018

PLATE NO.
MIS-1A

Plot Date: 06/20/2018
 Drawing Name: R:\condemal\pws\022018 Chaska Pumping Station\18.dwg
 Xrefs:

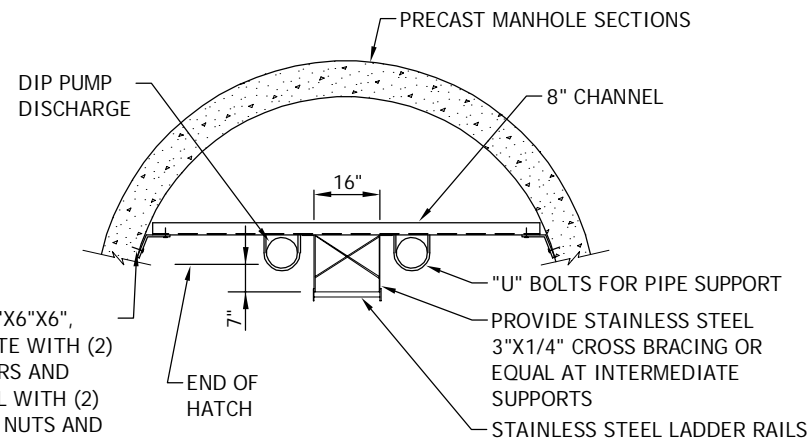

GALV. BENT L 3/8"x6"x6",
 BOLT TO CONCRETE WITH (2)
 3/4"φ S.S. ANCHORS AND
 BOLT TO CHANNEL WITH (2)
 3/4"φ S.S. BOLTS, NUTS AND
 WASHERS.

LADDER AND PIPE SUPPORT PLAN

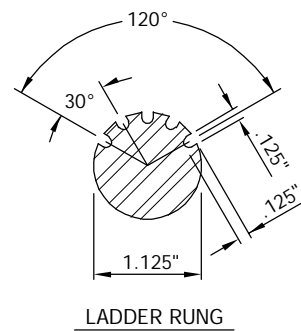

LADDER RUNG

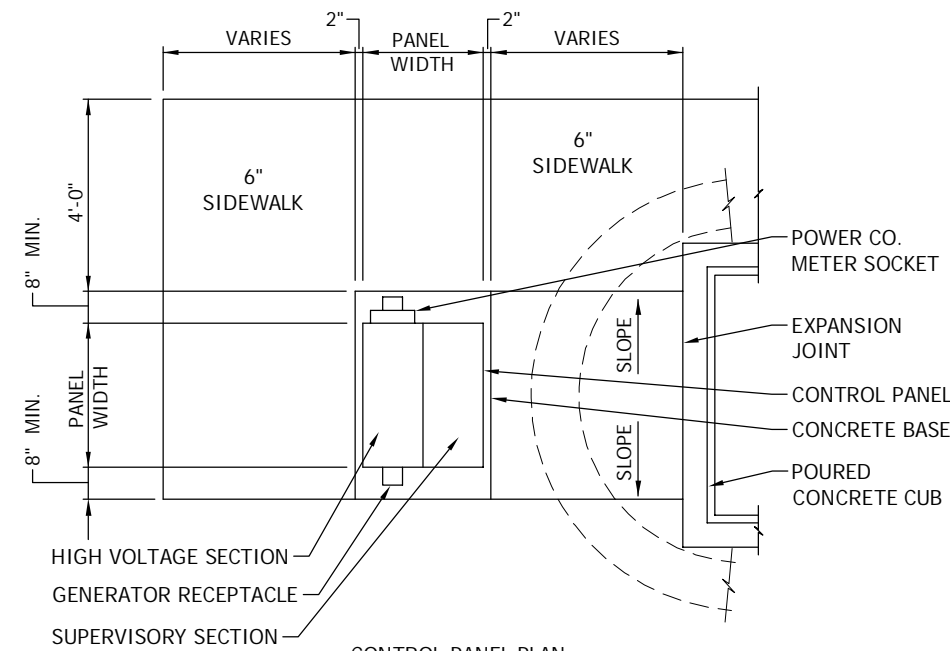

CONTROL PANEL PLAN

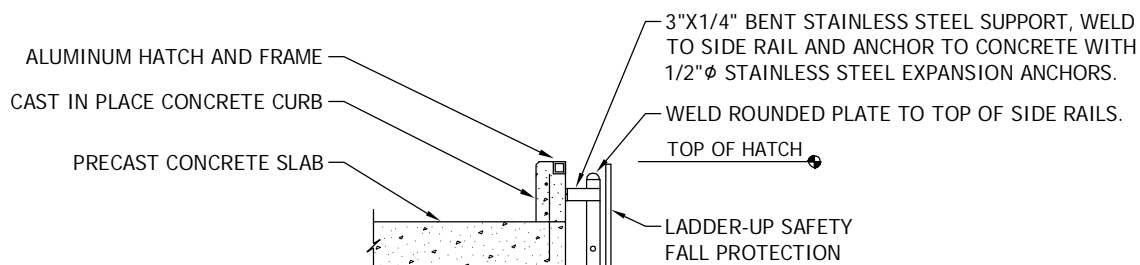

3"x1/4" BENT STAINLESS STEEL
 INTERMEDIATE SUPPORT, BOLT
 TO 8" CHANNEL WITH 1/2"
 STAINLESS STEEL BOLTS AND
 NUTS

NOTE:
 VERIFY LADDER
 LENGTH PRIOR
 TO FABRICATION.

C8X11.5 GALV. CHANNEL SUPPORT
 FOR PIPE AND LADDER. ATTACH
 TO THE TWO PIPES WITH 3/4"
 STAINLESS STEEL "U" BOLTS &
 DOUBLE NUT, 10 FT O.C. MAX.

1" STD. STAINLESS STEEL SERRATED
 PIPE RUNGS (1 5/16" OUTSIDE DIA.)
 RUNGS AT 12" ON CENTER

STAINLESS STEEL L 3X3X1/4 BOTTOM
 BRACKET, WELD TO SIDE RAILS AND
 ANCHOR TO CONCRETE
 WITH 1/2"φ STAINLESS STEEL
 ANCHORS

PRECAST CONCRETE BASE SLAB

LADDER AND PIPE SUPPORT SECTION

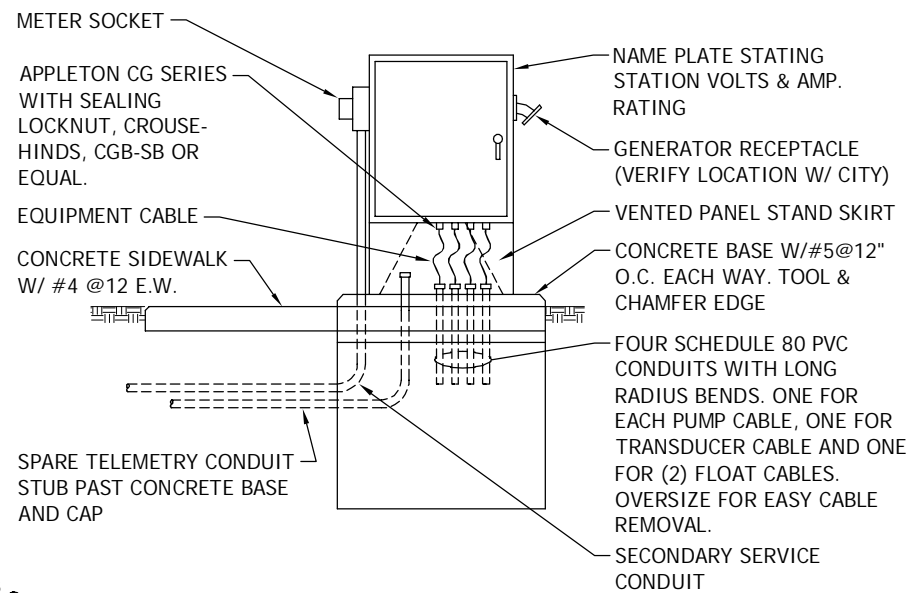

CONTROL PANEL ELEVATION

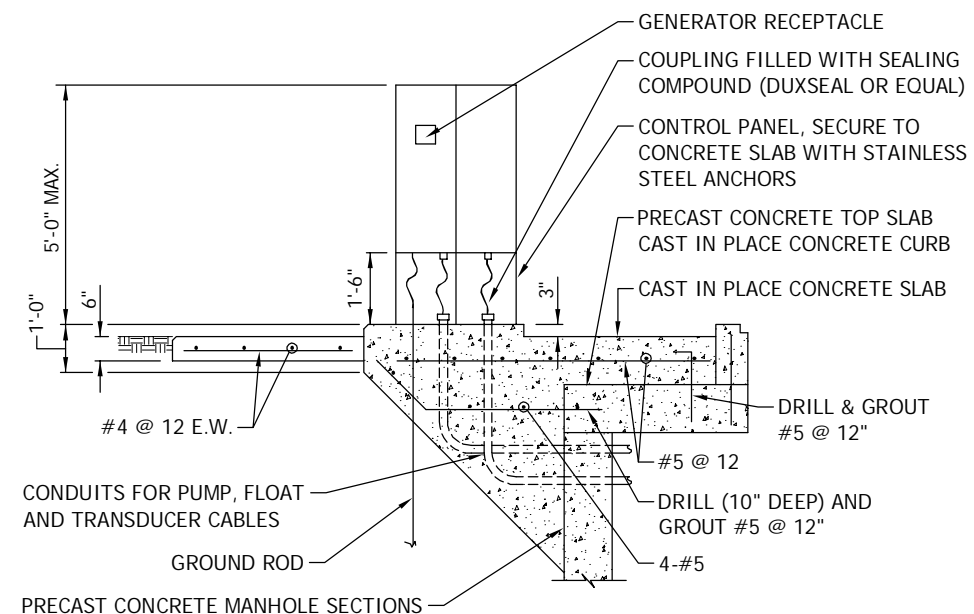

CONTROL PANEL SECTION



2335 Highway 36 W
 St. Paul, MN 55113
 www.stantec.com

WASTEWATER PUMPING STATION
 MISCELLANEOUS DETAILS

CHASKA, MINNESOTA

LAST REVISION:
 JUNE 2018

PLATE NO.
 MIS-1B

Plot Date: 06/20/2018
 Drawing Name: R:\condemal\p18s2018\Drawn\Planes\MS-1C.dwg
 Xrefs:

LIFT STATION CONTROL PANEL

